

# SAF MODUL

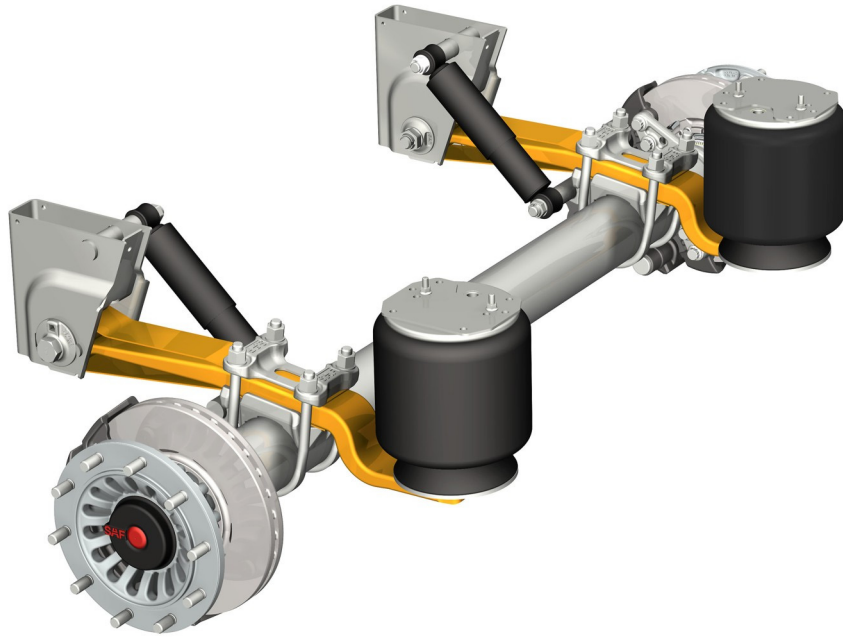

disc brake



drum brake

## General information

Serialnumber designation .....	5
Type identification for modul suspension .....	6
Type identification for axle generation SK .....	7
Type identification for axle generation 06 .....	8
Overview standard series at a glance .....	9
Overview special series at a glance .....	10
Deployment recommendations and classification of component criteria .....	11
Axle travel limitations at SAF air suspensions .....	12
Key .....	13
To choose a suspension assembly .....	14
Calculation of suspension assembly weight .....	14

## Air suspension types for axles with disc brake

Air suspension serie U; .....	15
Single leaf trailing arm (EN) 51 mm with air bag 2618V (29) or 2923V (31) .....	15
Air suspension serie MT; .....	16
Single leaf trailing arm (EN) 51 mm with air bag 2918V (27) or 2923V (31) .....	16
Air suspension serie M; .....	17
Single leaf trailing arm (EN) 51 mm with air bag 2618V (29) or 2923V (31) .....	17
Air suspension serie EO; .....	18
Single leaf trailing arm (EN) 51 mm with air bag 2618V (29) or 2923V (31) .....	18
Air suspension serie U; .....	19
Double leaf trailing arm (S) 43/43 mm with air bag 2918V (27) or 2923V (31) .....	19
Air suspension serie M; .....	20
Double leaf trailing arm (S) 43/43 mm with air bag 2918V (27) or 2923V (31) .....	20

## Rigid axles with disc brake

Axle version BI9-19 .....	21
Axle version B9-19 .....	22
Axle version SI9-19 .....	23
Axle version ZI9-19 .....	24
Axle version SI11-19K .....	25
Axle version ZI11-19K .....	26
Axle version BI9-22 .....	27
Axle version B9-22 .....	28
Axle version SI9-22 .....	29
Axle version ZI9-22 .....	30
Axle version SI11-22 .....	31
Axle version ZI11-22 .....	32

## Self steering axles with disc brake

Axle version SIL9-22 .....	33
----------------------------	----

## Air suspension types for axles with drum brake

Air suspension serie U;.....	34
Single leaf trailing arm (EN) 51 mm with air bag 2618V (29) or 2923V (31) .....	34
Air suspension serie M; .....	35
Single leaf trailing arm (EN) 51 mm with air bag 2618V (29) or 2923V (31) .....	35
Air suspension serie EO; .....	36
Single leaf trailing arm (EN) 51 mm with air bag 2618V (29) or 2923V (31) .....	36
Air suspension serie U;.....	37
Double leaf trailing arm (S) 43/43 mm with air bag 2918V (27) or 2923V (31) .....	37
Air suspension serie M; .....	38
Double leaf trailing arm (S) 43/43 mm with air bag 2918V (27) or 2923V (31) .....	38

## Rigid axles with drum brake

Axle version S7-3015 .....	39
Axle version Z7-3015.....	40
Axle version Z9-3020.....	41
Axle version Z11-3020.....	42
Axle version SK RZ 12030 .....	43
Axle version S9-3718 .....	44
Axle version Z9-3720.....	45
Axle version S11-3720 .....	46
Axle version Z11-3720.....	47
Axle version SK RZ 12037 .....	48
Axle version S9-4218 .....	49
Axle version Z9-4218.....	50
Axle version S11-4220 .....	51
Axle version Z11-4220.....	52
Axle version SK RS 12242 .....	53
Axle version SK RZ 12242 .....	54

## Self steering axles with drum brake

Axle version ZL11-3020.....	55
Axle version SL9-4218 .....	56

## Steered axles with drum brake

Axle version SK ZRLZ 12030 .....	57
----------------------------------	----

## Assembly components

Geometry hanger bracket „steel“ – bolted version .....	58
Geometry hanger bracket „steel“ – screwed version .....	59
Geometry hanger bracket „steel“ - „screw-on“ .....	60
Geometry cross member, rigid axle .....	61
Adjustable pivot bolt for hanger bracket „steel“ and cross member .....	62
Shock absorber assembly: hanger bracket „steel“ .....	63
Geometry hanger bracket „aluminium“ .....	64
Pivot bolt for hanger bracket „aluminium“ .....	65
Shock absorber assembly: hanger bracket „aluminium“ .....	66
Shock absorber overview .....	67
Calculation of free space between tyre and air bag. ....	68
Air bag overview .....	69
Calculation of the air bag pressure.....	70
Pressure-force diagram for air bag with diameter 300 mm .....	71
Pressure-force-diagram for air bag with diameter 350 mm.....	72
Mounting plates for air bag offset (V) overview .....	73
Overview air bag brackets .....	74
Surface coating of SAF components.....	75

## Axle lift

Two side axle lift for axles with drum brake.....	76
Two side axle lift types.....	77
Kit content - two side axle lift .....	78
Installation instruction .....	78
Circuit diagram, two side axle lift .....	79
Pendulum lift.....	80
Kit content pendulum lift.....	81
Installation instruction .....	81
Centre axle lift.....	82
For suspension series U with single- and double leaf trailing arm .....	82
For suspension serie M with single- and double leaf trailing arm.....	83
Circuit diagram, one sided or pendulum lift .....	84

## Installation and welding instructions

Welding instruction for hanger bracket „steel“ .....	85
Welding instruction for hanger bracket „aluminium“ .....	86
Recommendation for lateral reinforcement of hanger bracket „steel“ .....	87
Welding instruction for air bag bracket.....	88
Installation of hanger brackets „screw-on“ .....	89
Tightening torques for trailing arm – shock absorber - air bag.....	90
Tightening instructions for adjustable pivot bolt .....	91
Wheel fixing – Single 22,5“, drum brake (code 58).....	91
Wheel fixing – Single 22,5“, drum brake (code 58).....	92

## Brake chamber

Brake chamber bracket .....	93
Overview SAF-HOLLAND brake chamber for axles with disc brake.....	94
Installation instruction for brake chambers at axles with disc brake .....	96

## Self steering axles

Self-steering axle with pneumatic steering stabilising .....	97
Self-steering axle with stabilising damper .....	98

## Setting axle, suspension

Adjustment of the air suspension ride height .....	100
Ride heights.....	101
Axle alignment .....	102

## Miscellaneous

Classification of exciter ring teeth.....	104
Installation instruction ABS cable .....	105
Installation instruction, connecting cable kit for pad wear sensing.....	107
SAF-O-Meter .....	109

This manual is over the internet available. The newest version is always to be found with:

<http://designmanual.safholland.de>.



### Serialnumber designation

In the course of the world-wide standardization within the SAF-HOLLAND group the existing serial number on all products has been extended by one digit to 11 digits from 25.07.2009:

Example type plate from 25.07.2009:

SAF-HOLLAND GMBH D-63856 BESSENBACH • GERMANY			
Version <b>S9-4218</b>	Serial No. <b>11 09 307 0137</b>		
Type <b>SNK4218-11S</b>	Ident No. <b>147 95 02 2 58 3</b>		
Test Report <b>0381</b>	Perm. axle cap. stat. <b>9000</b> kg		
Made in Germany	V max. <b>105</b> km/h		
			
AN 3335528		SN 11093070137	

Coding:

**XX JJ TTT NNNN**

- XX**..... - Place of manufacture:
  - 11 – Germany, Plant 01
  - 12 – Germany, Plant 02
  - 13 – Germany, Plant 03 etc..
- JJ**..... - Year of manufacturing
- TTT**..... - Day of manufacturing
- NNNN**.... - Running number per day, year and place

Example serial number:

**11 09 307 0137**

This is about the **137th** product of the **307th** production day at the production year **2009** from the **plant 01 in Germany**.

## Type identification for modul suspension

Letters are marked with "X", numbers with "0"  
 Example:

**U27 / 2910S 31Q**  
**E044 / 2904EN27**  
**XX00 / 0000XX00X**

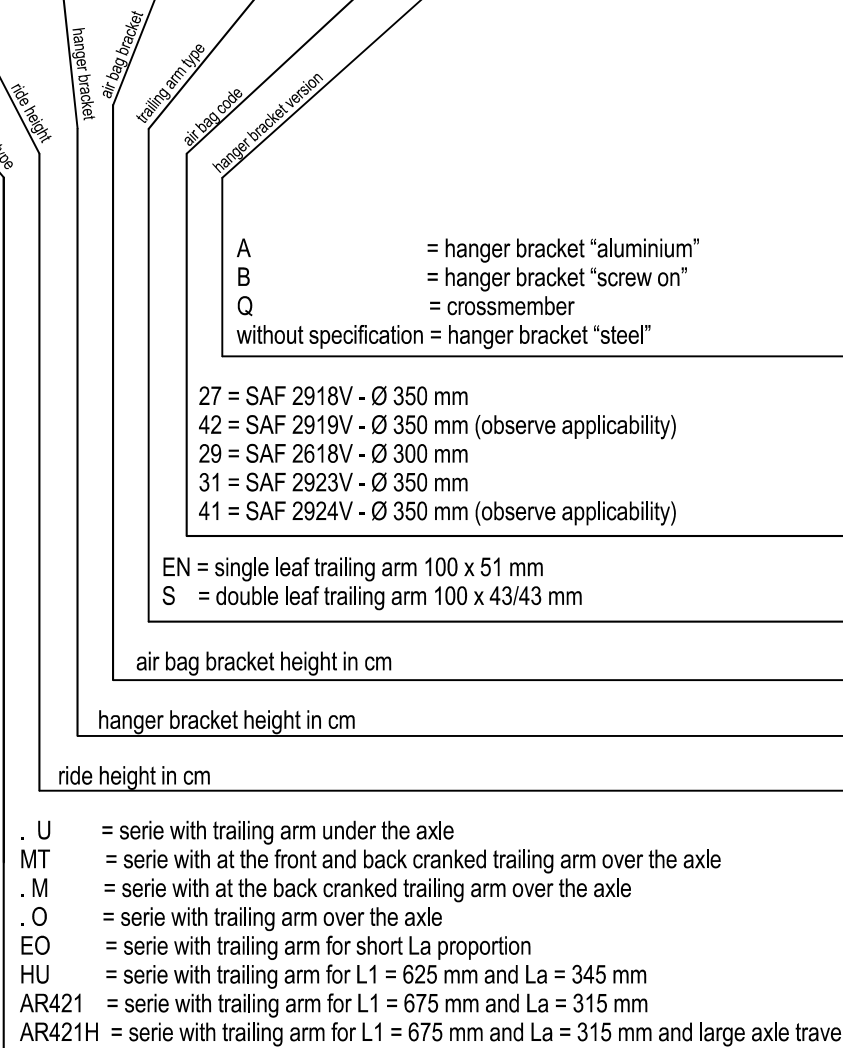

## Type identification for axle generation SK

### with drum brake

Letters are market with "X", numbers with "0"

Example:

SK R S 1 2242  
 SK Z R L Z 1 2030  
 SK (X)X(X)X (0)0000

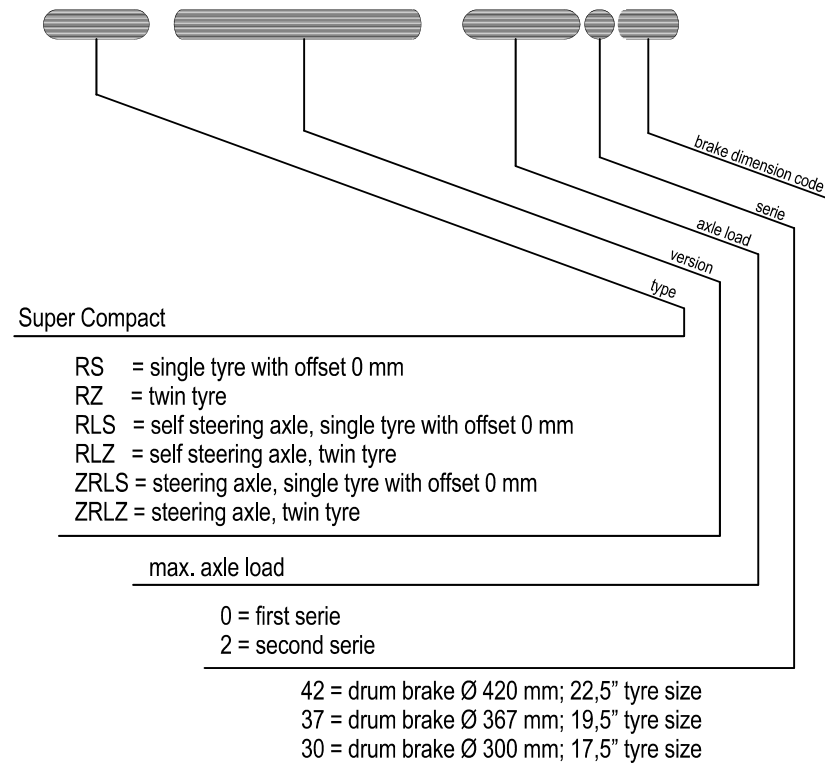

### Type identification for axle generation 06 with drum brake

Letters are marked with "X", numbers with "0"

Example:

S 9-4218  
Z L 1 1-3020  
X(X) (X) (0) 0-0000

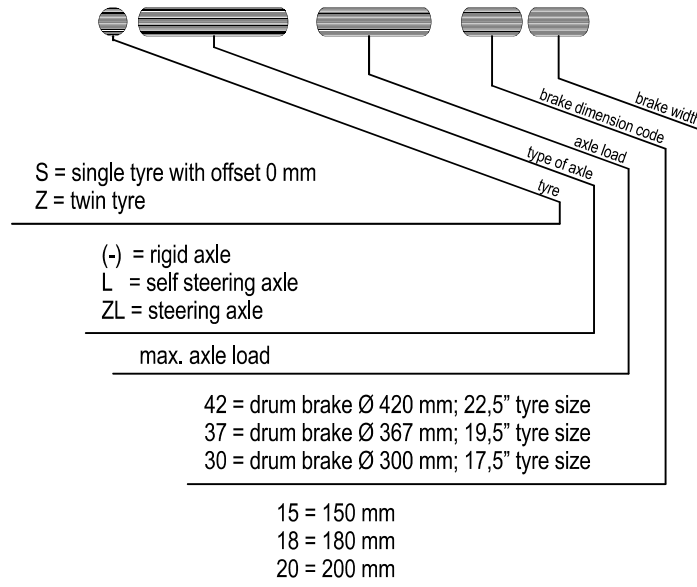

### with disc brake







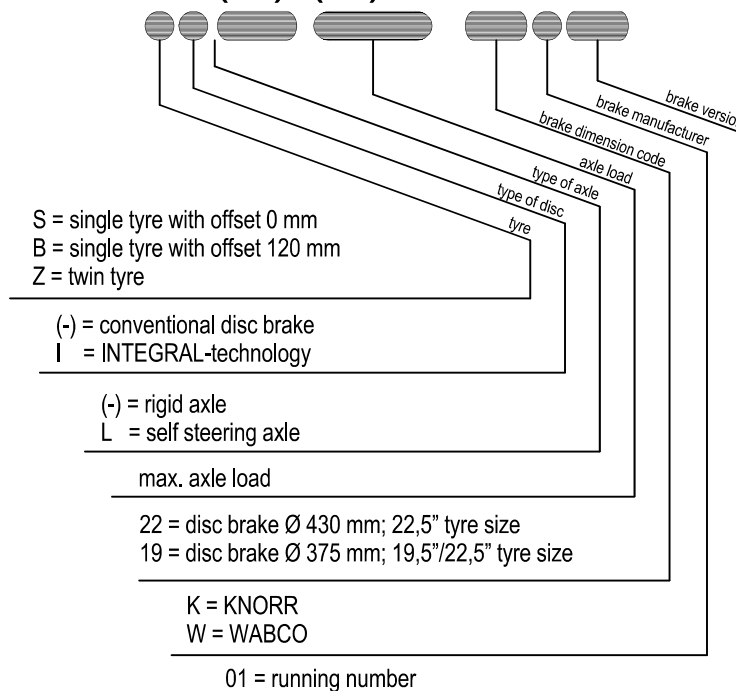

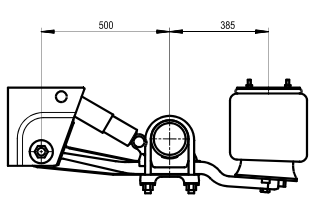

Letters are marked with "X", numbers with "0"

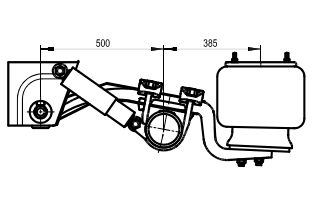
Example:

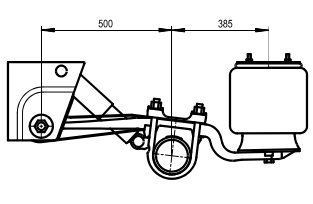

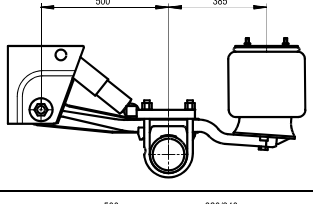

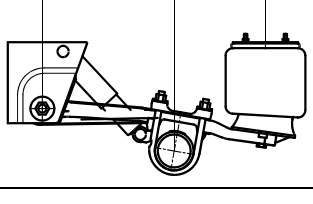

SI 1 1-22K01  
BI L 9-19W  
XX(X) (0) 0-00X00

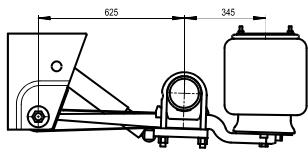

### Overview standard series at a glance

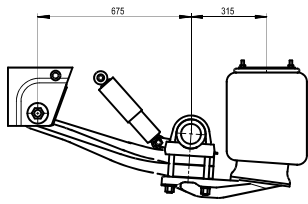
	Serie	Feature(s)	Trailing arm variations		F [mm]	Total axle travel with air bag:			
			[mm]			[mm]			
			100 x 51	100 x 43/43	2618V	2918V	2923V	2926V	
	<b>U</b>	trailing arm under the axle			170 till 380	180	180	200	260
	<b>MT</b>	cranked trailing arm over the axle			250 till 410	180	180	200	260
	<b>M</b>	cranked trailing arm over the axle			340 till 530	180	180	200	260
	<b>O</b>	trailing arm over the axle			400 till 600	180	180	200	260
	<b>EO</b>	trailing arm over the axle, short La-proportion			390 till 540	190	190	220	

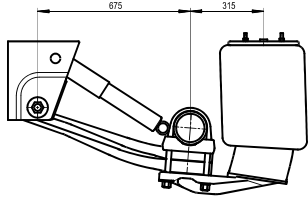
### Overview special series at a glance

	Serie	Feature(s)	Trailing arm variations		F	Total axle travel with air bag:		
			[mm]		[mm]	[mm]		
			100 x 61	100 x 54/54		2923V	2926V	3138
						<b>31</b>	<b>30</b>	nv.
			Ø350	Ø350	Ø390			
	<b>HU</b>	trailing arm under the axle, extended L1-proportion			<b>220</b> till <b>315</b>	260	300	
	<b>AR421</b>	trailing arm under the axle, extended L1-proportion			<b>250</b> till <b>500</b>		310	
	<b>AR421H</b>	trailing arm under the axle, extended L1-proportion			<b>380</b> till <b>480</b>			420 at 9 t; 400 at 10 t

### Deployment recommendations and classification of component criteria

Application	Axle load up to 105 km/h [t]	Spring centre (☐ = no limitations) [mm]	Trailing arm (width x breadth) [mm]	Axle beam	Air bag (Ø) [mm]	Spring seat	Notes
standard western Europe resp. on-road use	9	☐	100 x 51	standard	300/350	standard	for container- and coil-trailers: quick release valve or arresting cable
	11	≥ 1100	100 x 51		350	standard	
		☐	100 x 43/43		350	heavy duty	
mega-trailer	9	☐	100 x 60	standard	350	standard	long stroke
	11	☐	100 x 54/54		350	heavy duty	
eastern Europe or comparable conditions	9	≥ 1100	100 x 51	reinforced	350	standard	for container- and coil-trailers: quick release valve or arresting cable
	11	☐	100 x 43/43		350	heavy duty	
	9	≥ 1100	100 x 51		350	standard	
	11	☐	100 x 43/43		350	heavy duty	
tipper western Europe	9	☐	100 x 51	reinforced	350	standard	quick release valve or arresting cable
tipper heavy use	9	≥ 1100	100 x 51	reinforced	350	standard	quick release valve or arresting cable
		☐	100 x 43/43		350	heavy duty	
	11	☐	100 x 43/43		350	heavy duty	
	12	☐	100 x 43/43		350	heavy duty	
logging	9	☐	100 x 51	reinforced	350	standard	quick release valve or arresting cable
	11	☐	100 x 43/43		350	heavy duty	
	12	☐	100 x 43/43		350	heavy duty	

Amendments and errors excepted. XL-AS10004DM-en-DE Rev B © SAF-HOLLAND



## Axle travel limitations at SAF air suspensions

Basically it is in the design of SAF air suspension that there is no need for axle travel limitations. However there are some to operational conditions required exceptions:

Operating condition	Sling	Height limiting valve
<b>Raise- and lowering device</b> (e.g. adapting trailer to bank heights/ demountable body systems)	⇒ <b>REQUIRED</b> (alternative height limiting valve)	<b>NOT REQUIRED</b> when raise/ lower valve with <b>DEADMAN HANDLE</b> is fitted
<b>Roll on/ Roll off applications</b>  ⇒ with air pressure in the air bags  ⇒ without air pressure in the air bags (wit SAF standard air bags and use of anti-vacuum-valve)	⇒ <b>REQUIRED</b>  ⇒ <b>REQUIRED</b> (rubber part of the air bag has to stay rolled on over the piston at maximum axle travel)	
<b>Quick discharging</b> for example coil-trailers  ⇒ with raise and lowering device (discharging in „raised“ position)	⇒ <b>REQUIRED</b>	
<b>Ferry operation</b>  ⇒ with air pressure in the air bags  ⇒ without air pressure in the air bags (wit SAF standard air bags and use of anti-vacuum-valve)	⇒ <b>REQUIRED</b>  ⇒ <b>REQUIRED</b> (rubber part of the air bag has to stay rolled on over the piston at maximum axle travel)	

## Key

Summary	Explanation
A	Unsprung mass
AX	Distance wheel attachment faces left to right
B	Total width
BH	Hanger bracket height, distance centre pivot bolt to top side hanger bracket
BL	Hanger bracket length, distance top hanger bracket from front- to backside
BM	Air bag centre, distance air bag centre line between left- and right side
ET	Offset, distance wheel attachment face to centre tyre
DP	Pivot point centre (steering axle), distance pivot bolts centre line between left- and right side
F	Nominal ride height, distance centre axle to bottom chassis in driving condition
G	Total axle width
H	Air bag bracket height
H <sub>2</sub>	Air bag bracket height at lift air bag
HM	Hanger bracket centre, distance hanger bracket centre line between left- and right side
Hmax	Air bag height maximum
Hmin	Air bag height minimum
i	Ratio
K	Brake chamber centre (with drum brake), centre distance brake chamber bracket between left- and right side
KTL	Cathodic dip coating
L	Trailing arm length (L1), distance centre pivot bolt to centre axle (standard 500 mm)
La	Distance centre axle to centre air bag (L2, standard 385 mm)
LM	Spring centre, centre distance spring between left- and right side
Lmax	Shock absorber length maximum
Lmin	Shock absorber length minimum
P	Air pressure in the air bag (Mpa)
p	Air pressure in the air bag (Mpa/kg)
Pt	Air pressure in the air bag at partial load (Mpa)
Q	Axle load on the ground (kg)
Qt	Axle load on the ground at partial load (kg)
S	Track, centre distance tyres between left- and right side
V	Air bag offset, distance centre air bag to centre spring
X	Overall height, distance centre axle to under side of chassis beam when air bags are without air
Y	Installation height of liftarm, when raised.

All measurements are given in mm if not specified otherwise.

## To choose a suspension assembly

For example an assembly with the following data:

Air suspension: Overall height (**X**), unladen without air: 275 mm  
lowering travel: 90 mm  
adjusted ride height (**F**): 365 mm  
standard air bag Ø 300 mm  
spring centre: 1300 mm

Axle: axle with disc brake 22,5", axle load maximum 9.000 kg  
tyre size: 385/65R22,5" on a wheel with offset 0 mm  
total width (distance outside tyres left to right) maximum: 2490 mm

With this data:

Suspension as on [page 17](#), air suspension for axles with disc brake.  
Air suspension type: M36/2500EN29.

Axle as on [page 29](#), axle with disc brake 22,5". Axle version: SI9-22K01  
Tyre 385/65R22,5" has a width of 405 mm (E.T.R.T.O. Norm).  
With a maximum total width of 2490 mm you can choose a distance wheel attachment faces up to a maximum of  $(2490 - 405 + 2 \times 0 =) 2085$  mm.

For this the suspension assembly is described as:  
M36/2500EN29 SI9-22K01  
Distance wheel attachment faces: 2040 mm  
Spring centre: 1300 mm

With an air bag offset of 30 mm you'll get a free space between tyre and air bag of:  
Calculation:

$$\frac{AX - LM - \text{Balgdurchmesser} - \text{Reifenbreite}}{2} + V - ET \geq 25\text{mm}$$

$$\frac{2040 - 1300 - 300 - 405}{2} + 30 - 0 = 47,5 \geq 25\text{mm}$$

see also [page 68](#)

## Calculation of suspension assembly weight

The total weight of this assembly is the sum of the weights of air suspension type and axle.

M36/2500EN29	weight air suspension type ( <a href="#">page 17</a> )	174 kg
SI9-22K01, distance wheel attachment faces 2040 mm	weight axle ( <a href="#">page 29</a> )	308 kg
	total weight suspension assembly:	482 kg

Weights are without slack adjusters (axles with drum brake), brake chambers and wheel nuts. Weight deviations lie within the permitted DIN tolerances for the respective manufacturing process.

**Air suspension serie U;  
Single leaf trailing arm (EN) 51 mm with air bag 2618V (29) or 2923V (31)  
Nominal ride heights 270 – 365 mm**

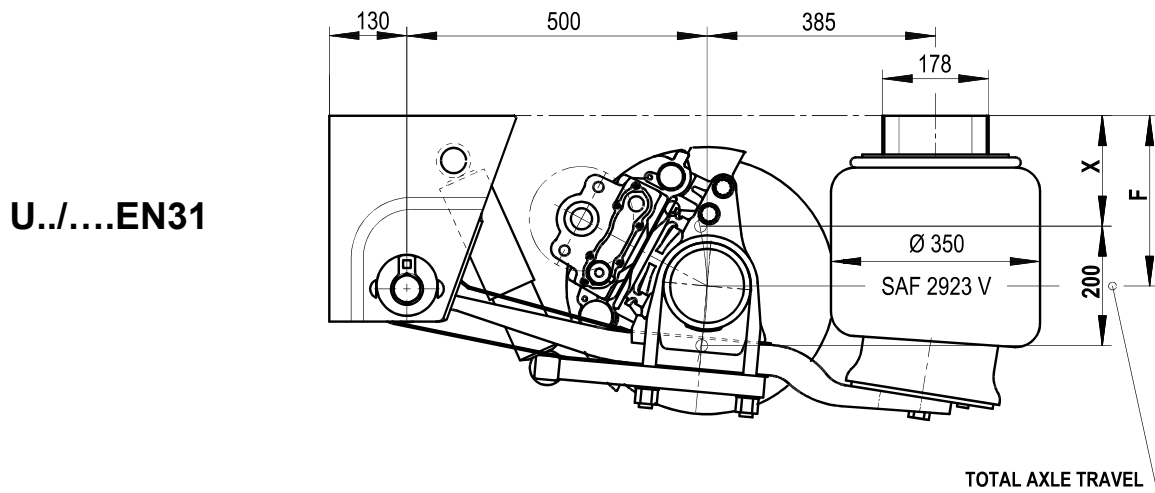
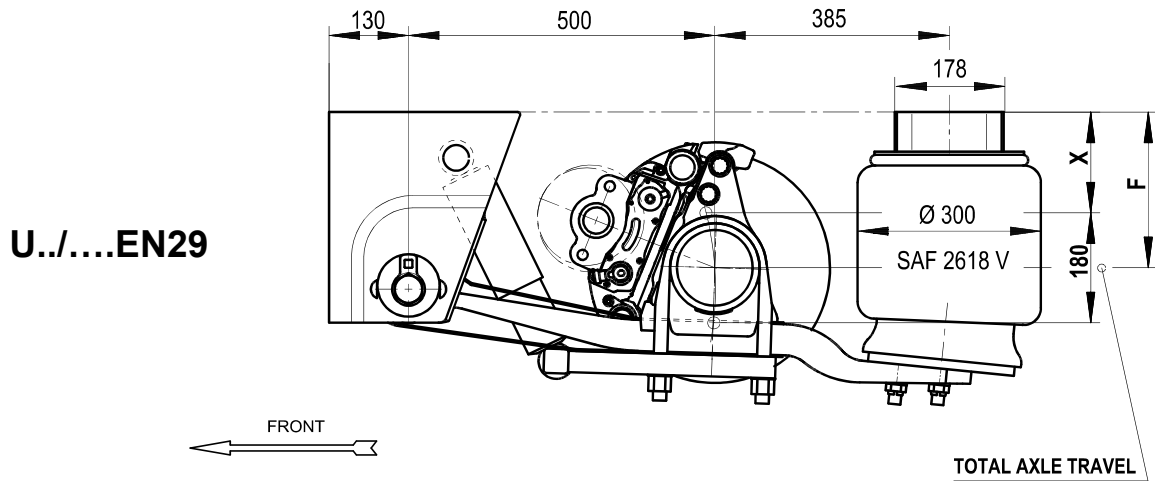

air suspension type	F; nominal ride height [mm]	ride height range [mm]	X; overall height <sup>1)</sup>		weight approx. <sup>2)</sup> [kg]
			unladen without air [mm]	laden without air [mm]	
U27/2910EN29	270	250-290	180	165	189
U33/3516EN29	330	310-350	240	225	193
U28/2907EN31	285	255-315	185	170	203
U30/2910EN31	300	270-330	200	185	204
U33/3510EN31	330	300-360	230	215	206
U35/3513EN31	350	320-380	250	235	207
U36/3516EN31	365	335-395	265	250	208

1) The data in the table corresponds with an air bag offset (V) of 0 or 30 mm, with V = 55 mm or V = 70 mm the overall height X is increased by 5 mm (so changes the ride height range accordantly)

2) Weight deviations lie within the permitted DIN Tolerances for the respective manufacturing process.

Use of cross member and hanger bracket „aluminium“ is not applicable.

Further variants on request

**Air suspension serie MT;**  
**Single leaf trailing arm (EN) 51 mm with air bag 2918V (27) or 2923V (31)**  
Nominal ride heights 250 – 410 mm

**MT../....EN27**

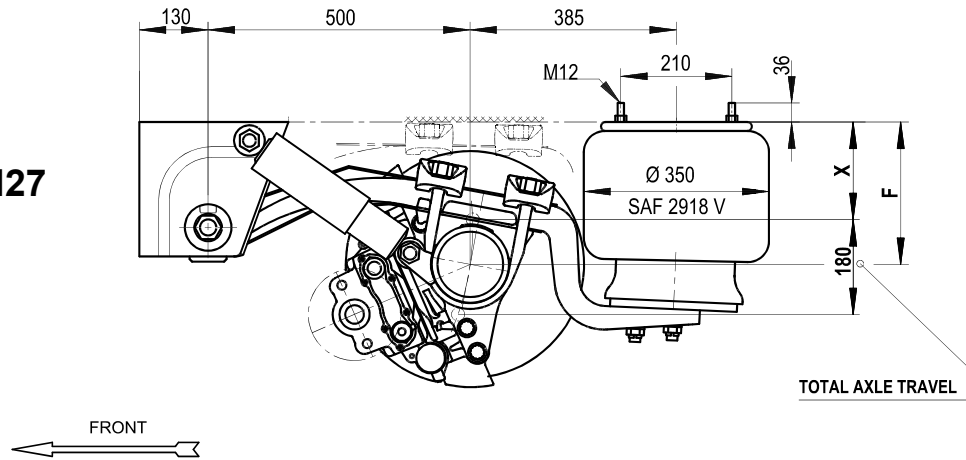

**MT../....EN31**

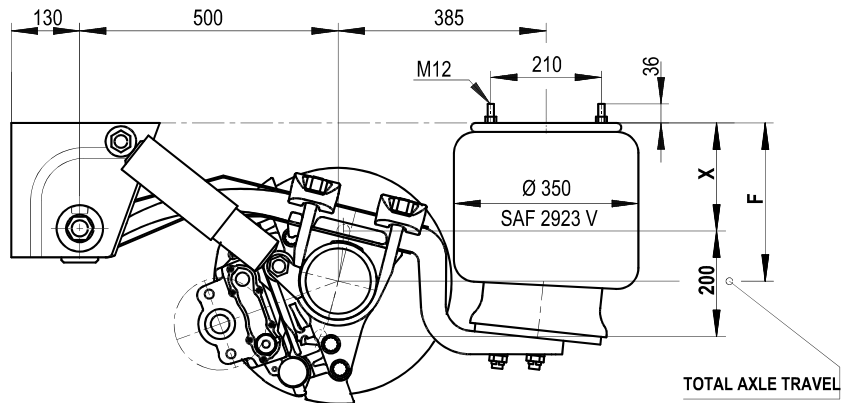

air suspension type	F; nominal ride height [mm]	ride height range [mm]	X; overall height <sup>1)</sup>		weight approx. <sup>2)</sup> [kg]
			unladen without air [mm]	laden without air [mm]	
MT27/2000EN27 <sup>3)</sup>	270	250-290	180	180	188
MT30/2005EN27	300	280-320	210	195	193
MT32/2505EN27	320	300-340	230	215	196
MT35/2510EN27	350	330-370	260	245	198
MT30/2000EN31	305	275-335	205	190	190
MT33/2005EN31	330	300-360	230	215	195
MT35/2505EN31	355	325-385	255	240	198
MT38/2510EN31	380	350-410	280	265	200

- 1) The data in the table corresponds with an air bag offset (V) of 0 or 30 mm, with V = 55 mm or V = 70 mm the overall height X is increased by 5 mm (so changes the ride height range accordingly)
- 2) Weight deviations lie within the permitted DIN Tolerances for the respective manufacturing process.
- 3) Air suspension types MT27/2000EN27 and MT27/2000EN29, contact at the axle clamping to chassis beam in position without air (unladen without air = laden without air)

Further variants on request.

**Air suspension serie M;  
Single leaf trailing arm (EN) 51 mm with air bag 2618V (29) or 2923V (31)**  
Nominal ride heights 365 – 500 mm

**M../....EN29**

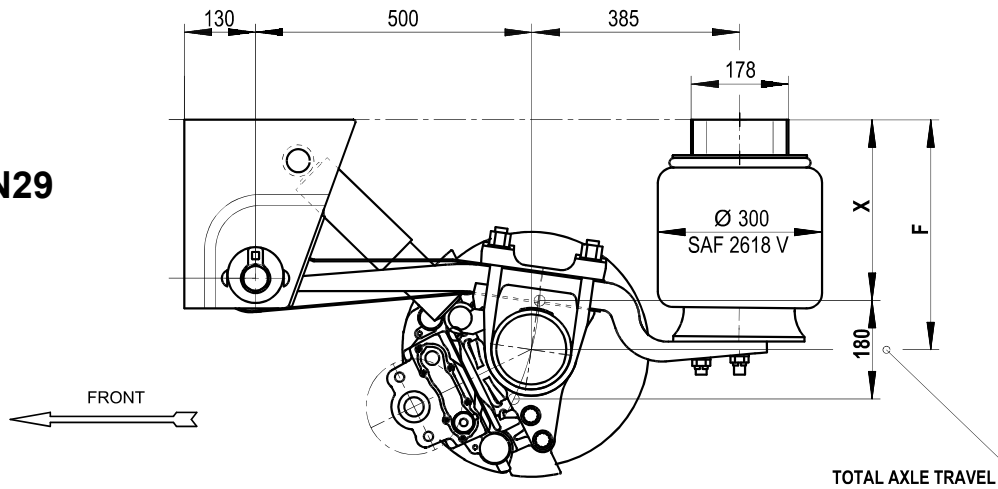

**M../....EN31**

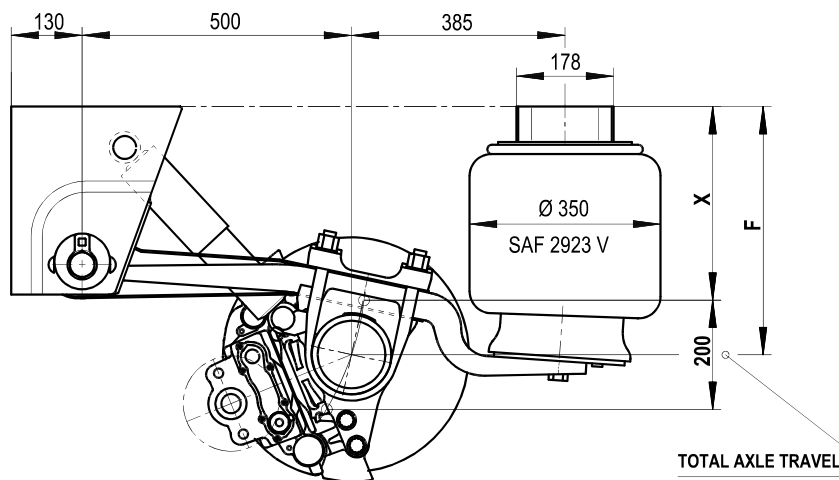

air suspension type	F; nominal ride height [mm]	ride height range [mm]	X; overall height <sup>1)</sup>		weight approx. <sup>2)</sup> [kg]
			unladen without air [mm]	laden without air [mm]	
M36/2500EN29	365	345-385	275	260	174
M38/2504EN29	385	365-405	295	280	175
M40/2904EN29	400	380-420	310	295	178
M42/2907EN29	420	400-440	330	315	179
M43/2910EN29	435	415-455	345	330	180
M46/3510EN29	465	445-485	375	360	185
M40/2500EN31	400	370-430	300	285	189
M42/2504EN31	420	390-450	320	305	190
M43/2904EN31	435	405-465	335	320	193
M45/2907EN31	455	425-485	355	340	194
M47/2910EN31	470	440-500	370	355	195
M50/3510EN31	500	470-530	400	385	200

1) The data in the table corresponds with an air bag offset (V) of 0 or 30 mm, with V = 55 mm or V = 70 mm the overall height X is increased by 5 mm (so changes the ride height range accordingly)

2) Weight deviations lie within the permitted DIN Tolerances for the respective manufacturing process.

Further variants on request.

**Air suspension serie EO;**  
**Single leaf trailing arm (EN) 51 mm with air bag 2618V (29) or 2923V (31)**  
Nominal ride heights 410 – 545 mm

**EO../....EN29**

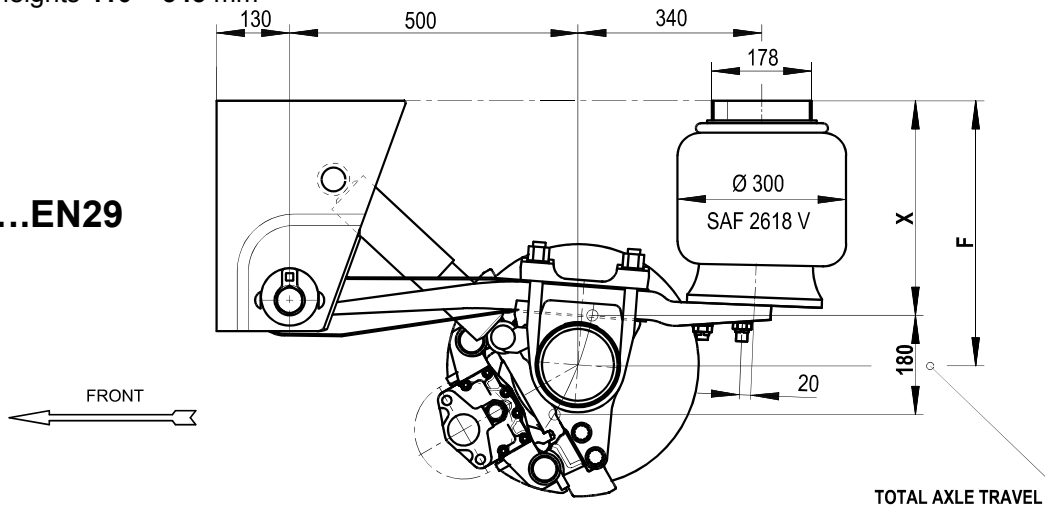

**EO../....EN31**

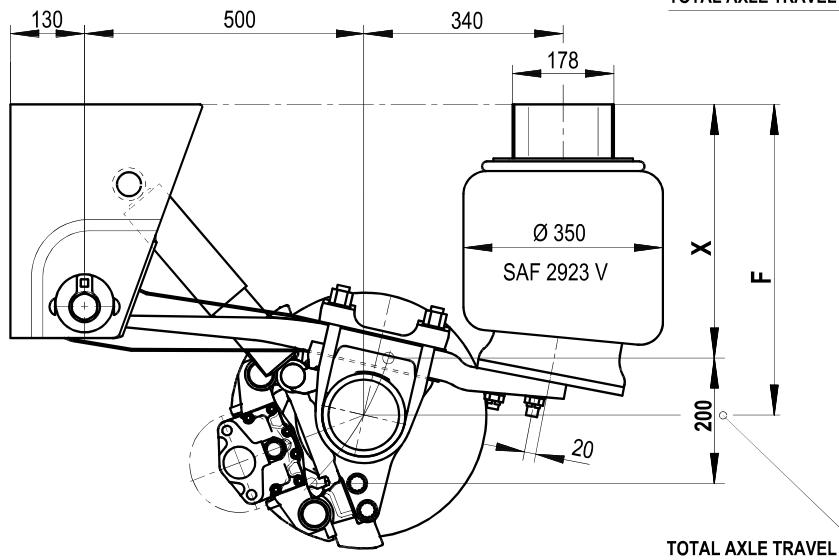

air suspension type	F; nominal ride height [mm]	ride height range [mm]	X; overall height <sup>1)</sup>		weight approx. <sup>2)</sup> [kg]
			unladen without air [mm]	laden without air [mm]	
EO41/2500EN29	410	400-440	330	315	173
EO42/2900EN29	425	415-455	345	330	176
EO44/2904EN29	445	435-475	365	350	177
EO47/3504EN29	470	460-500	390	375	182
EO49/3507EN29	490	480-520	410	395	183
EO50/3510EN29	505	495-535	425	410	184
EO44/2500EN31	445	425-485	355	340	188
EO46/2900EN31	460	440-500	370	355	191
EO48/2904EN31	480	460-520	390	375	192
EO50/3504EN31	505	485-545	415	400	197
EO52/3507EN31	525	505-565	435	420	198
EO54/3510EN31	545	525-585	455	440	199

1) The data in the table corresponds with an air bag offset (V) of 0, 30, 55 or 70 mm.

2) Weight deviations lie within the permitted DIN Tolerances for the respective manufacturing process.

Further variants on request.



**Air suspension serie U;  
Double leaf trailing arm (S) 43/43 mm with air bag 2918V (27) or 2923V (31)**  
Nominal ride heights 270 – 365 mm

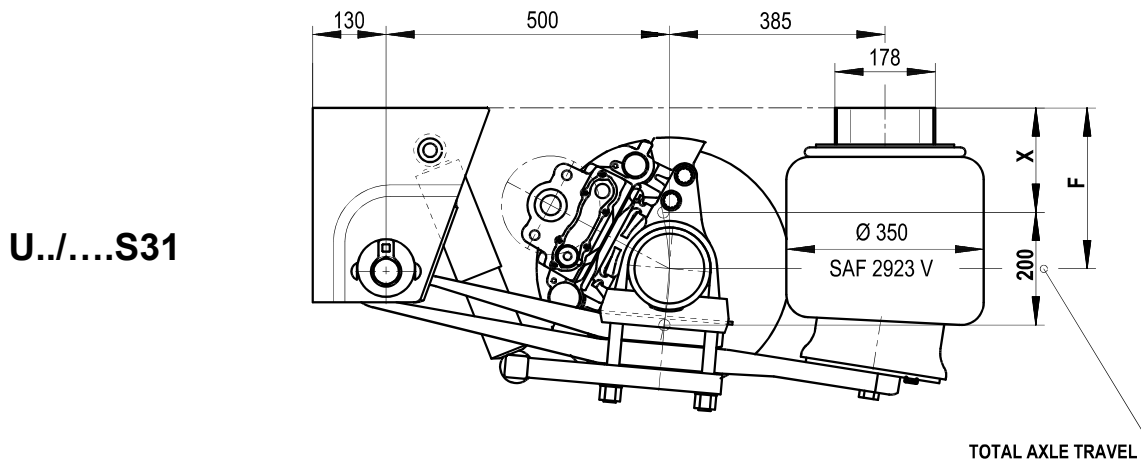
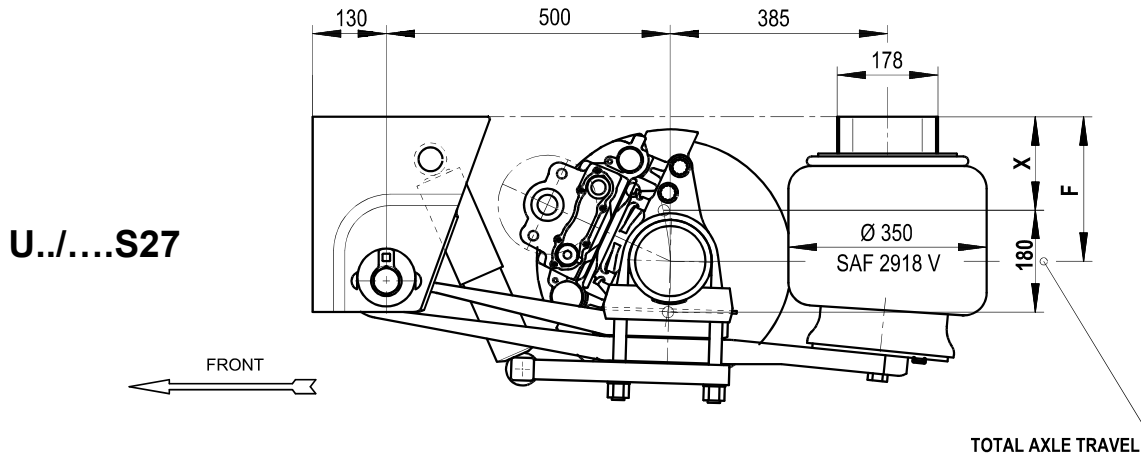

air suspension type	F; nominal ride height [mm]	ride height range [mm]	X; overall height <sup>1)</sup>		weight approx. <sup>2)</sup> [kg]
			unladen without air [mm]	laden without air [mm]	
U27/2910S27	270	250-290	180	170	221
U33/3516S27	330	310-350	240	230	225
U28/2907S31	285	260-320	190	180	222
U30/2910S31	300	275-335	205	195	223
U33/3510S31	330	305-365	240	230	225
U35/3513S31	350	325-385	255	245	226
U36/3516S31	365	340-400	270	260	227

1) The data in the table corresponds with an air bag offset (V) of 0 or 30 mm, with V = 55 mm or V = 70 mm the overall height X is increased by 5 mm (so changes the ride height range accordingly)

2) Weight deviations lie within the permitted DIN Tolerances for the respective manufacturing process.

Use of cross member and hanger bracket „aluminium“ is not applicable.

Further variants on request.

**Air suspension serie M;  
Double leaf trailing arm (S) 43/43 mm with air bag 2918V (27) or 2923V (31)**  
Nominal ride heights 365 – 500 mm

**M../....S27**

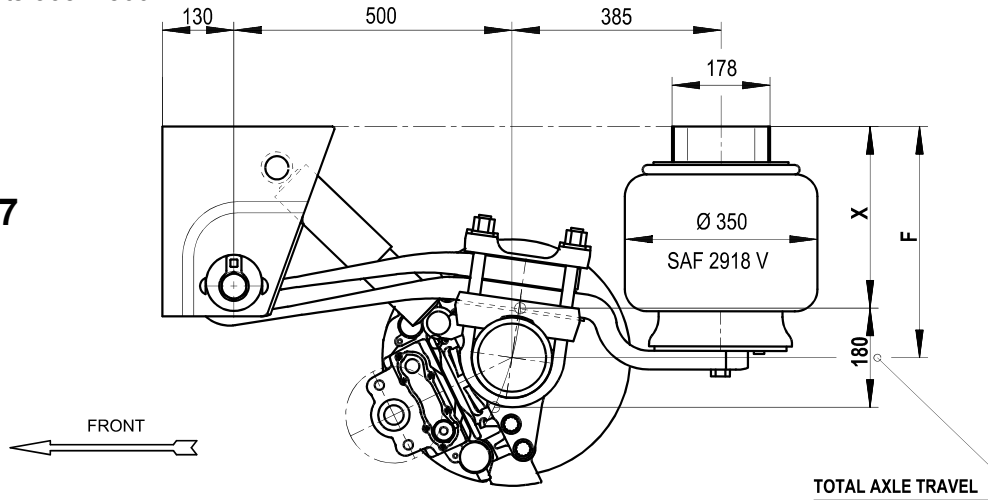

**M../....S31**

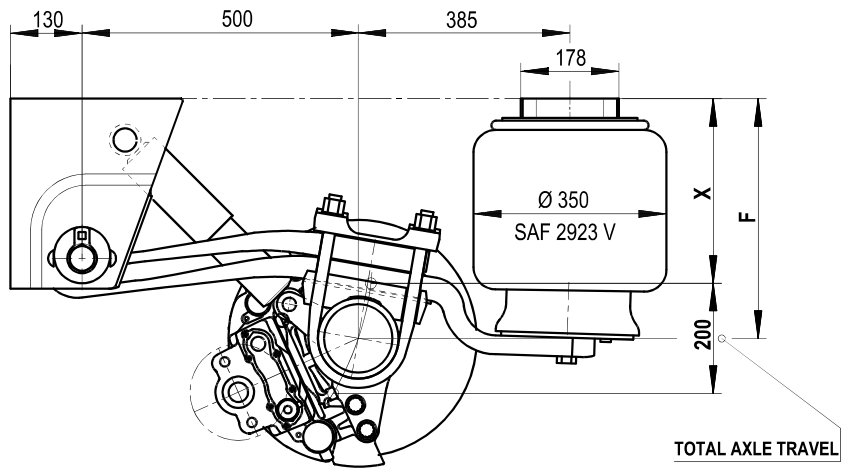

air suspension type	F; nominal ride height [mm]	ride height range [mm]	X; overall height <sup>1)</sup>		weight approx. <sup>2)</sup> [kg]
			unladen without air [mm]	laden without air [mm]	
M36/2500S27	365	350-395	280	270	209
M38/2504S27	385	370-410	300	290	210
M40/2904S27	400	385-425	315	305	213
M42/2907S27	420	405-445	335	325	214
M43/2910S27	435	420-460	350	340	215
M46/3510S27	465	450-490	380	370	220
M40/2500S31	400	375-435	305	295	211
M42/2504S31	420	395-455	325	315	212
M43/2904S31	435	410-470	340	330	215
M45/2907S31	455	430-490	360	350	216
M47/2910S31	470	445-505	375	365	217
M50/3510S31	500	475-535	405	395	222

1) The data in the table corresponds with an air bag offset (V) of 0 or 30 mm, with V = 55 mm or V = 70 mm the overall height X is increased by 5 mm (so changes the ride height range accordingly)

2) Weight deviations lie within the permitted DIN Tolerances for the respective manufacturing process.

Further variants on request.

**Axle version BI9-19...**

Axle load maximum: **9.000 kg**

Axle beam **Ø 146 mm**

Wheel fixing: **10 / 280 / 335 / 22x1,5 mm**

Suitable for: Air suspension series **U, MT, M, EO** with single leaf trailing arm (**EN**) and

Air suspension series **U, M** with double leaf trailing arm (**S**)

Air bags with air bag diameter **Ø 300 mm** and **Ø 350 mm**

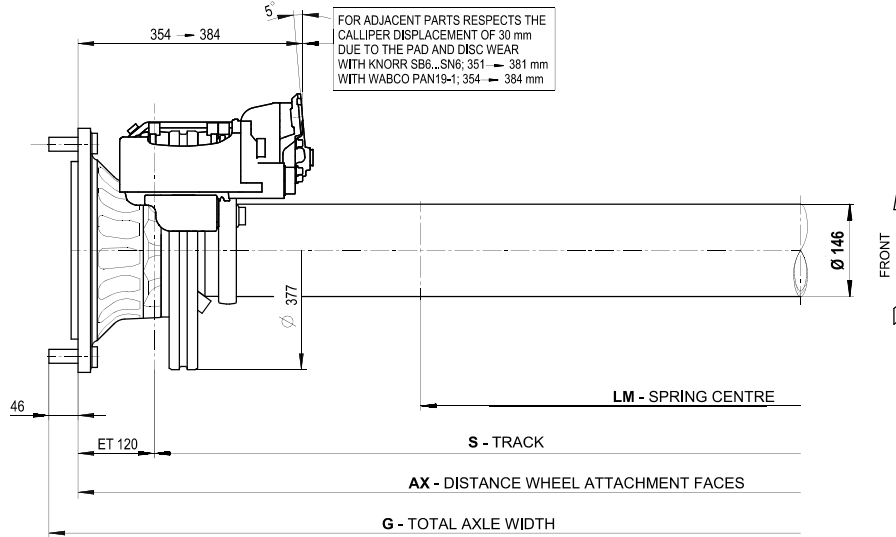

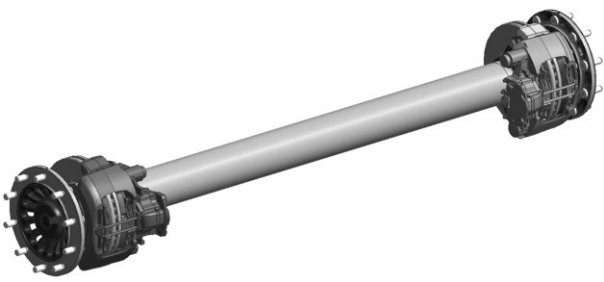
axle version / axle type / brake / test report	AX / LM	S <sup>1)</sup> / LM	G <sup>2)</sup>	weight approx. <sup>3)</sup>
	[mm]	[mm]	[mm]	[kg]
 <b>BI9-19W</b> / SBW1937-11S / WABCO, PAN19-1+ / TDB0678 <b>BI9-19K</b> / SBK1937- / KNORR, SB6...SN6 / TDB0605	tyre (example): 425/55R19,5"			
	2210/1100	1970/1100	2302	283
	2210/1200 <sup>5)</sup>	1970/1200 <sup>5)</sup>	2302	283
	2280/1200	2040/1200	2372	286
	2280/1300 <sup>5)</sup>	2040/1300 <sup>5)</sup>	2372	286
	2330/1300 <sup>4)</sup>	2090/1300 <sup>4)</sup>	2422	288
	2380/1300	2140/1300	2472	291
2380/1400 <sup>5)</sup>	2140/1400 <sup>5)</sup>	2472	291	

1) **S = AX - 2 \* ET (120 mm)**

2) **G** is increased by 20 mm when wheel studs are used for mounting aluminium rims.

3) without spring seats, brake chambers and wheel nuts (spring seats are enclosed in the air suspension).  
Weight deviations lie within the permitted DIN Tolerances for the respective manufacturing process.

4) with tyres **425/55R19,5"** and air bag diameter **Ø 350 mm** starting at **V = 30 mm**

5) with tyres **425/55R19,5"** and air bag diameter **Ø 350 mm** starting at **V = 55 mm**

Note:

When choosing the suspension assembly, the clearance between air bag (max. diameter) and chosen tyre must be checked, this should be at least **25 mm**.

Further variants on request.

**Axle version B9-19...**

Axle load maximum: **9.000 kg**

Axle beam **Ø 146 mm**

Wheel fixing: **10 / 280 / 335 / 22x1,5 mm**

Suitable for: Air suspension series **U, MT, M, EO** with single leaf trailing arm (**EN**) and

Air suspension series **U, M** with double leaf trailing arm (**S**)

Air bags with air bag diameter **Ø 300 mm** and **Ø 350 mm**

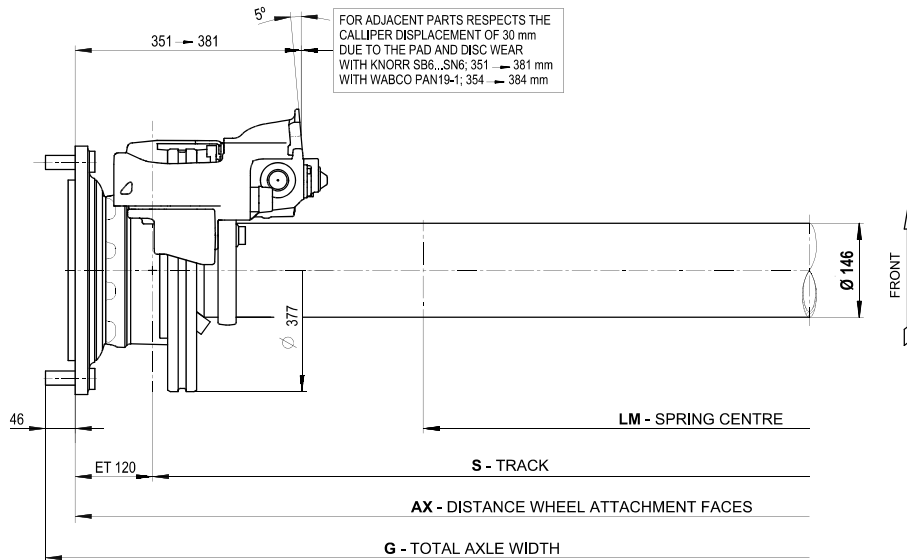

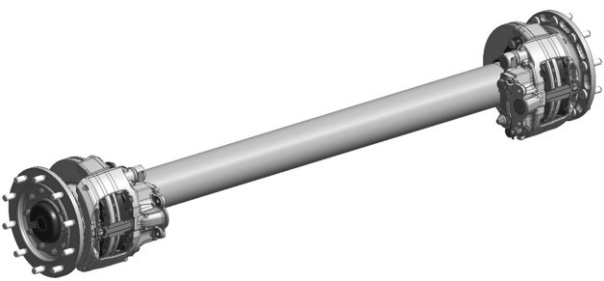
axle version / axle type / brake / test report	AX / LM [mm]	S <sup>1)</sup> / LM [mm]	G <sup>2)</sup> [mm]	weight approx. <sup>3)</sup> [kg]
	tyre (example): 425/55R19,5"			
 <b>B9-19W / SBW1937-11S / WABCO, PAN19-1+ / TDB0678</b> <b>B9-19K / SBK1937- / KNORR, SB6...SN6 / TDB0605</b>	2210/1100	1970/1100	2302	283
	2210/1200 <sup>5)</sup>	1970/1200 <sup>5)</sup>	2302	283
	2280/1200	2040/1200	2372	286
	2280/1300 <sup>5)</sup>	2040/1300 <sup>5)</sup>	2372	286
	2330/1300 <sup>4)</sup>	2090/1300 <sup>4)</sup>	2422	288
	2380/1300	2140/1300	2472	291
	2380/1400 <sup>5)</sup>	2140/1400 <sup>5)</sup>	2472	291

1) **S = AX – 2 \* ET (120 mm)**

2) **G** is increased by 20 mm when wheel studs are used for mounting aluminium rims.

3) without spring seats, brake chambers and wheel nuts (spring seats are enclosed in the air suspension). Weight deviations lie within the permitted DIN Tolerances for the respective manufacturing process.

4) with tyres **425/55R19,5"** and air bag diameter **Ø 350 mm** starting at **V = 30 mm**

5) with tyres **425/55R19,5"** and air bag diameter **Ø 350 mm** starting at **V = 55 mm**

Note:

When choosing the suspension assembly, the clearance between air bag (max. diameter) and chosen tyre must be checked, this should be at least **25 mm**.

Further variants on request.

**Axle version S19-19.**

Axle load maximum: **9.000 kg**

Axle beam **Ø 146 mm**

Wheel fixing: **8 / 220 / 275 / 22x1,5 mm**

Suitable for: Air suspension series **U, MT, M, EO** with single leaf trailing arm (**EN**) and  
 Air suspension series **U, M** with double leaf trailing arm (**S**)  
 Air bags with air bag diameter **Ø 300 mm** and **Ø 350 mm**

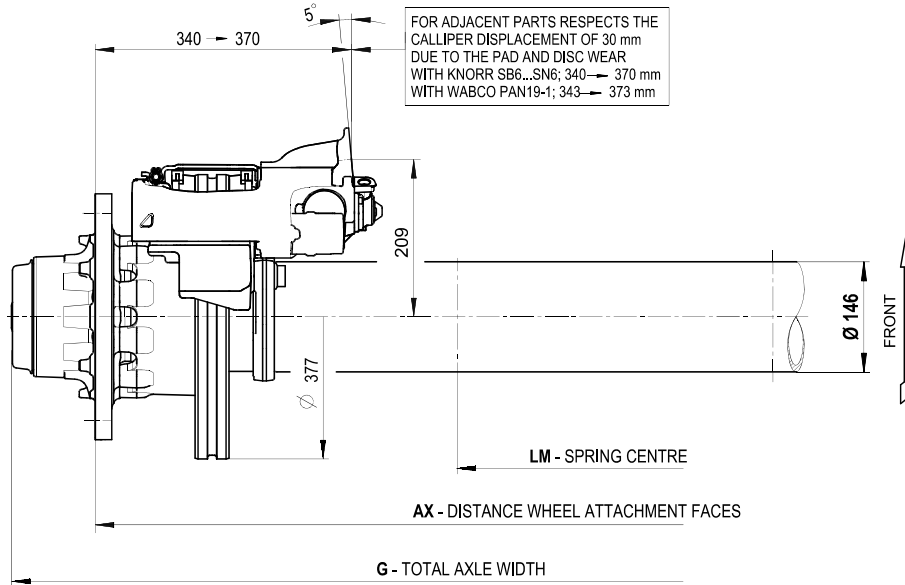

axle version / axle type / brake / test report	AX <sup>1)</sup> / LM [mm]	G [mm]	weight approx. <sup>2)</sup> [kg]
 <b>S19-19K</b> / SBK1937- / KNORR SB6...SN6 / TDB0605 <b>S19-19W</b> / SBW1937-11S / WABCO PAN19-1+ / TDB0678	tyre (example): 425/55R19,5"		
	1970/1100	2192	278
	1970/1200 <sup>4,5)</sup>	2192	278
	2040/1200	2262	281
	2040/1300 <sup>4,5)</sup>	2262	281
2090/1300 <sup>3,5)</sup>	2312	283	

- 1) **AX = S**
- 2) without spring seats, brake chambers and wheel nuts (spring seats are enclosed in the air suspension).  
Weight deviations lie within the permitted DIN Tolerances for the respective manufacturing process.
- 3) with tyres **425/55R19,5"** and air bag diameter **Ø 350 mm** starting at **V = 30 mm**
- 4) with tyres **425/55R19,5"** and air bag diameter **Ø 350 mm** starting at **V = 55 mm**
- 5) to be combined with air suspension types starting at a nominal ride height of **330 mm**.

Note:

When choosing the suspension assembly, the clearance between air bag (max. diameter) and chosen tyre must be checked, this should be at least **25 mm**.

Further variants on request.

**Axle version Z19-19.**

Axle load maximum: **9.000 kg**

Axle beam **Ø 146 mm**

Wheel fixing: **8 / 220 / 275 / 22x1,5 mm**

Suitable for: Air suspension series **U, MT, M, EO** with single leaf trailing arm (**EN**) and  
 Air suspension series **U, M** with double leaf trailing arm (**S**)  
 Air bags with air bag diameter **Ø 300 mm** and **Ø 350 mm**

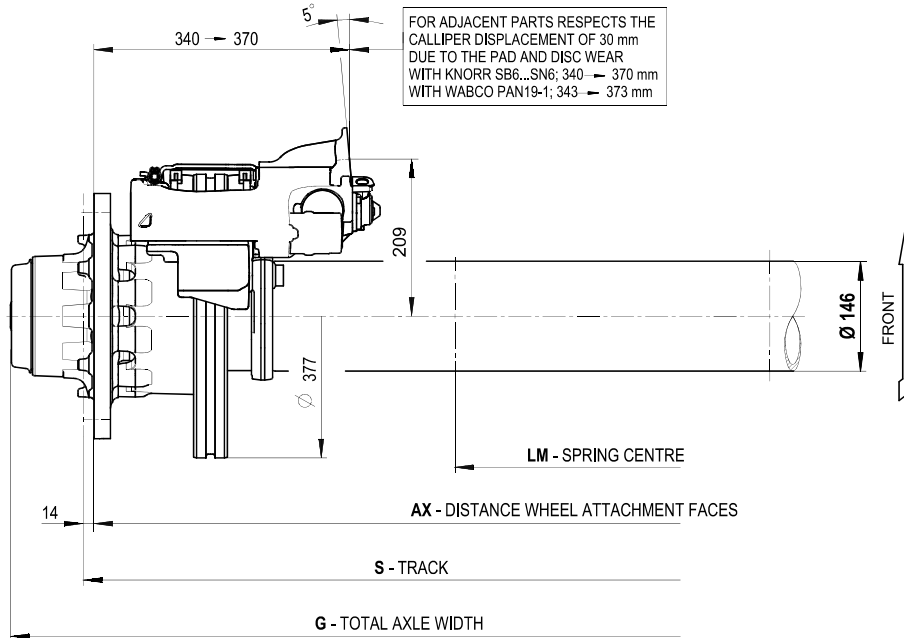

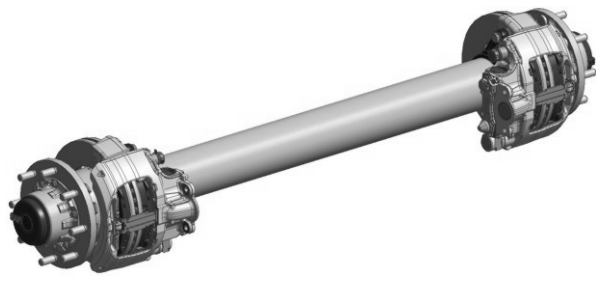
axle version / axle type / brake / test report	AX / LM [mm]	S <sup>1)</sup> / LM [mm]	G [mm]	weight approx. <sup>2)</sup> [kg]
	tyre (example): 265/70R19,5"			
 <b>Z19-19K</b> / SBK1937- / KNORR SB6...SN6 / TDB0606 <b>Z19-19W</b> / SBW1937- / WABCO PAN19-1+ / TDB0749	1806/900 <sup>3)</sup>	1834/900 <sup>3)</sup>	2028	291
	1806/980 <sup>5)</sup>	1834/980 <sup>5)</sup>	2028	291
	1860/900	1888/900	2082	293
	1860/980 <sup>4)</sup>	1888/980 <sup>4)</sup>	2082	293
	1926/1050 <sup>4)</sup>	1954/1050 <sup>4)</sup>	2148	296
	1926/1100 <sup>5)</sup>	1954/1100 <sup>5)</sup>	2148	296

- 1) **S** = **AX** + 2 \* wheel disc thickness (standard 14 mm)
- 2) without spring seats, brake chambers and wheel nuts (spring seats are enclosed in the air suspension).  
Weight deviations lie within the permitted DIN Tolerances for the respective manufacturing process.
- 3) with tyres **265/70R19,5"** and air bag diameter **Ø 350 mm** starting at **V = 30 mm**
- 4) with tyres **265/70R19,5"** and air bag diameter **Ø 350 mm** starting at **V = 55 mm**
- 5) with tyres **265/70R19,5"** and air bag diameter **Ø 350 mm** only with **V = 70 mm**

Note:  
 When choosing the suspension assembly, the clearance between air bag (max. diameter) and chosen tyre must be checked, this should be at least **25 mm**.

Further variants on request.

**Axle version SI11-19K**

Axle load maximum: **11.000 kg**

Axle beam **Ø 146 mm**

Wheel fixing: **8 / 220 / 275 / 22x1,5 mm**

Suitable for: Air suspension series **U, MT, M, EO** with single leaf trailing arm (**EN**) and  
 Air suspension series **U, M** with double leaf trailing arm (**S**)  
 Air bag with air bag diameter **Ø 300 mm** and **Ø 350 mm**

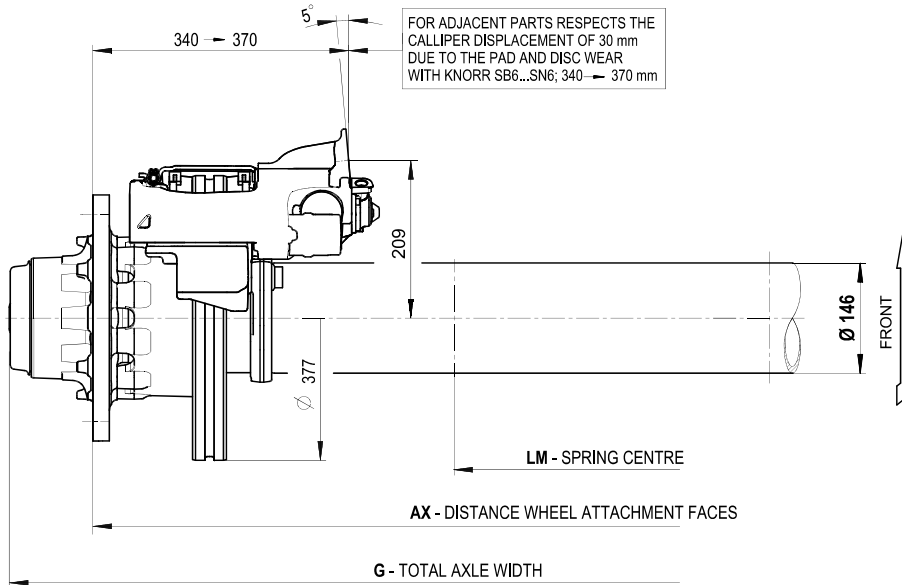

axle version / axle type / brake / test report	AX <sup>1)</sup> / LM [mm]	G [mm]	weight approx. <sup>2)</sup> [kg]
 <b>SI11-19K / SBK1937- / KNORR SB6...SN6 / TDB0605</b>	tyre (example): 445/65R19,5"		
	1970/1100 <sup>3)</sup>	2192	290
	1970/1200 <sup>4,6)</sup>	2192	290
	2040/1300 <sup>5,6)</sup>	2262	293

- 1) **AX = S**
- 2) without spring seats, brake chambers and wheel nuts (spring seats are enclosed in the air suspension). Weight deviations lie within the permitted DIN Tolerances for the respective manufacturing process.
- 3) with tyres **465/65R19,5"** and air bag diameter **Ø 350 mm** starting at **V = 30 mm**
- 4) with tyres **465/65R19,5"** and air bag diameter **Ø 350 mm** starting at **V = 55 mm**
- 5) with tyres **465/65R19,5"** and air bag diameter **Ø 350 mm** starting at **V = 70 mm**
- 6) to be combined with air suspension types starting at a nominal ride height of **330 mm**.

Note:  
 When choosing the suspension assembly, the clearance between air bag (max. diameter) and chosen tyre must be checked, this should be at least **25 mm**.

Further variants on request.



**Axle version ZI11-19K**

Axle load maximum: **11.000 kg**

Axle beam **Ø 146 mm**

Wheel fixing: **8 / 220 / 275 / 22x1,5 mm**

Suitable for: Air suspension series **U, M** with double leaf trailing arm (**S**)

Air bags with air bag diameter **Ø 350 mm**

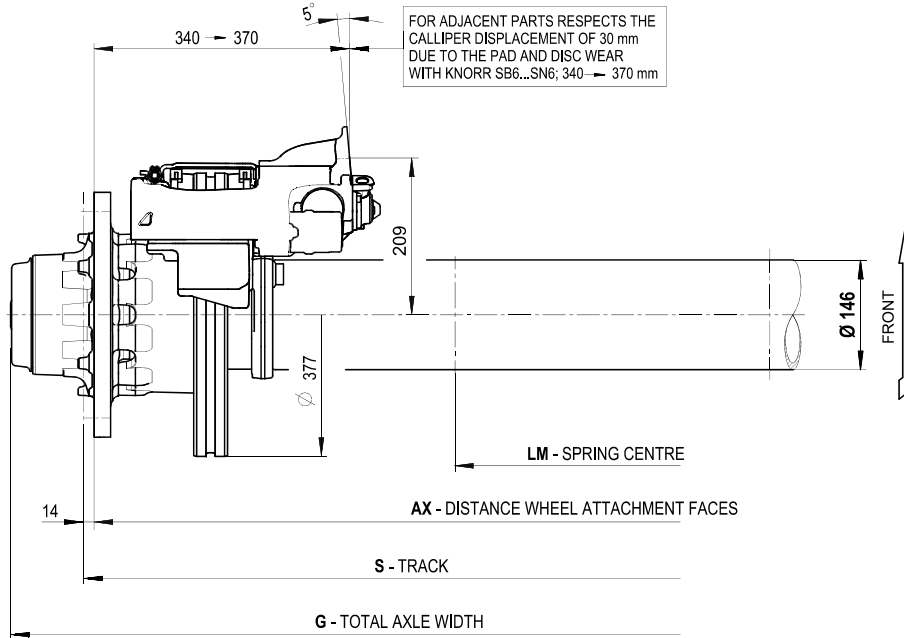

axle version / axle type / brake / test report	AX / LM [mm]	S <sup>1)</sup> / LM [mm]	G [mm]	weight approx. <sup>2)</sup> [kg]
	tyre (example): 265/70R19,5"			
 <b>ZI11-19K / SBK1937- / KNORR SB6...SN6 / TDB0606</b>	1806/900 <sup>3)</sup>	1834/900 <sup>3)</sup>	2028	291
	1806/980 <sup>5)</sup>	1834/980 <sup>5)</sup>	2028	291
	1860/900	1888/900	2082	293
	1860/980 <sup>4)</sup>	1888/980 <sup>4)</sup>	2082	293
	1926/1050 <sup>4)</sup>	1954/1050 <sup>4)</sup>	2148	296
	1926/1100 <sup>5)</sup>	1954/1100 <sup>5)</sup>	2148	296

- 1) **S = AX + 2 \* wheel disc thickness (standard 14 mm)**
- 2) without spring seats, brake chambers and wheel nuts (spring seats are enclosed in the air suspension). Weight deviations lie within the permitted DIN Tolerances for the respective manufacturing process.
- 3) with tyres **265/70R19,5"** and air bag diameter **Ø 350 mm** starting at **V = 30 mm**
- 4) with tyres **265/70R19,5"** and air bag diameter **Ø 350 mm** starting at **V = 55 mm**
- 5) with tyres **265/70R19,5"** and air bag diameter **Ø 350 mm** only with **V = 70 mm**

Note:  
When choosing the suspension assembly, the clearance between air bag (max. diameter) and chosen tyre must be checked, this should be at least **25 mm**.

Further variants on request.

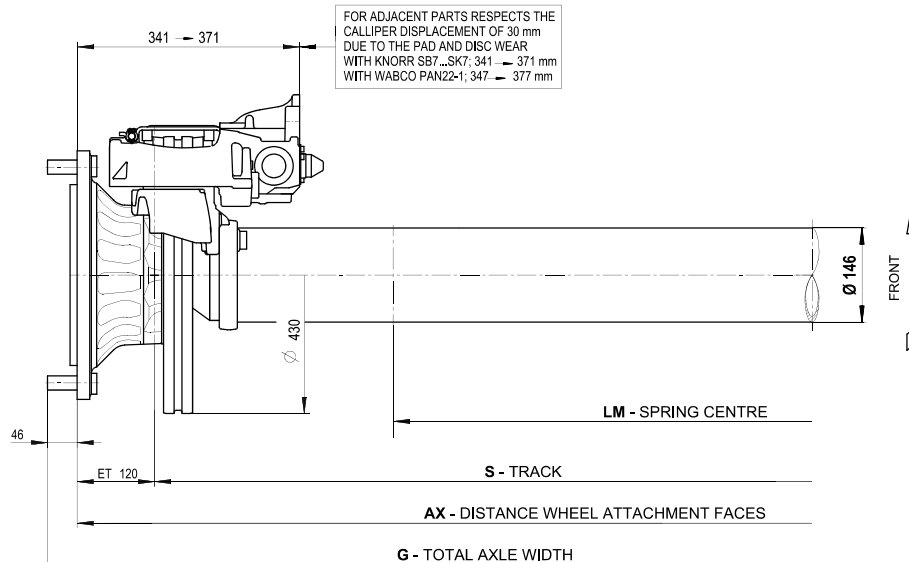
**Axle version BI9-22...**Axle load maximum: **9.000 kg**Axle beam **Ø 146 mm**Wheel fixing: **10 / 280 / 335 / 22x1,5 mm**Suitable for: Air suspension series **U, MT, M, EO** with single leaf trailing arm (**EN**) andAir suspension series **U, M** with double leaf trailing arm (**S**)Air bags with air bag diameter **Ø 300 mm** and **Ø 350 mm**

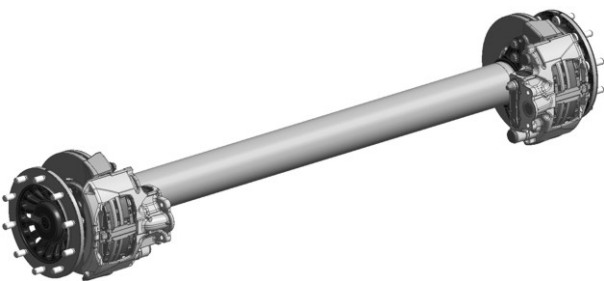
axle version / axle type / brake / test report	AX / LM [mm]	S <sup>1)</sup> / LM [mm]	G <sup>2)</sup> [mm]	weight approx. <sup>3)</sup> [mm]
 <b>BI9-22K01</b> / SBK2243- / KNORR, SB7...SK7 / 36110303 <b>BI9-22W</b> / SBW2243-11S / WABCO, PAN22-1 / 36110702	tyre (example): 385/65R22,5"			
	2210/1100	1970/1100	2302	310
	2210/1200 <sup>4)</sup>	1970/1200 <sup>4)</sup>	2302	310
	2280/1200	2040/1200	2372	313
	2280/1300 <sup>5)</sup>	2040/1300 <sup>5)</sup>	2372	313
	2330/1300 <sup>4)</sup>	2090/1300 <sup>4)</sup>	2422	315
	2380/1300	2140/1300	2472	317
2380/1400 <sup>5)</sup>	2140/1400 <sup>5)</sup>	2472	317	

1) **S = AX – 2 \* ET (120 mm)**2) **G** is increased by **20 mm** when wheel studs are used for mounting aluminium-rims.3) without spring seats, brake chambers and wheel nuts (spring seats are enclosed in the air suspension).  
Weight deviations lie within the permitted DIN Tolerances for the respective manufacturing process.4) with tyres **385/65R22,5"** and air bag diameter **Ø 350 mm** starting at **V = 30 mm**5) with tyres **385/65R22,5"** and air bag diameter **Ø 350 mm** starting at **V = 55 mm**

## Note:

When choosing the suspension assembly, the clearance between air bag (max. diameter) and chosen tyre must be checked, this should be at least **25 mm**.

Further variants on request.

**Axle version B9-22...**

Axle load maximum: **9.000 kg**

Axle beam **Ø 146 mm**

Wheel fixing: **10 / 280 / 335 / 22x1,5 mm**

Suitable for: Air suspension series **U, MT, M, EO** with single leaf trailing arm (**EN**) and

Air suspension series **U, M** with double leaf trailing arm (**S**)

Air bags with air bag diameter **Ø 300 mm** and **Ø 350 mm**

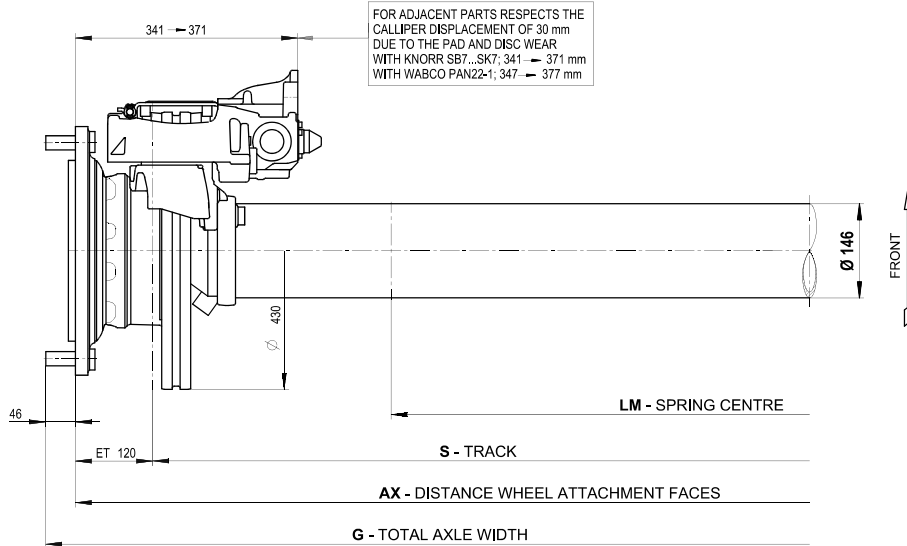

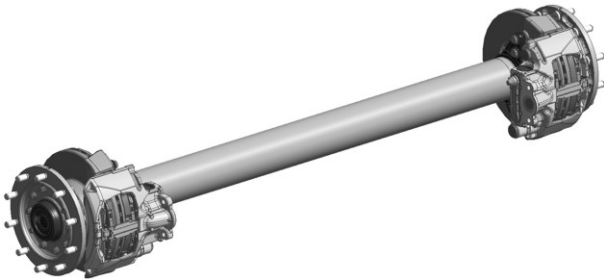
axle version / axle type / brake / test report	AX / LM [mm]	S <sup>1)</sup> / LM [mm]	G <sup>2)</sup> [mm]	weight approx. <sup>3)</sup> [kg]
	tyre (example): 385/65R22,5"			
 <p><b>B9-22K01</b> / SBK2243- / KNORR, SB7...SK7 / 36110303  <b>B9-22W</b> / SBW2243-11S / WABCO, PAN22-1 / 36110702</p>	2210/1100	1970/1100	2302	310
	2210/1200 <sup>4)</sup>	1970/1200 <sup>4)</sup>	2302	310
	2280/1200	2040/1200	2372	313
	2280/1300 <sup>5)</sup>	2040/1300 <sup>5)</sup>	2372	313
	2330/1300 <sup>4)</sup>	2090/1300 <sup>4)</sup>	2422	315
	2380/1300	2140/1300	2472	317
	2380/1400 <sup>5)</sup>	2140/1400 <sup>5)</sup>	2472	317

1) **S = AX - 2 \* ET (120 mm)**

2) **G** is increased by **20 mm** when wheel studs are used for mounting aluminium-rims.

3) without spring seats, brake chambers and wheel nuts (spring seats are enclosed in the air suspension). Weight deviations lie within the permitted DIN Tolerances for the respective manufacturing process.

4) with tyres **385/65R22,5"** and air bag diameter **Ø 350 mm** starting at **V = 30 mm**

5) with tyres **385/65R22,5"** and air bag diameter **Ø 350 mm** starting at **V = 55 mm**

Note:

When choosing the suspension assembly, the clearance between air bag (max. diameter) and chosen tyre must be checked, this should be at least **25 mm**.

Further variants on request.

**Axle version S19-22...**

Axle load maximum: **9.000 kg**

Axle beam **Ø 146 mm**

Wheel fixing: **10 / 280 / 335 / 22x1,5 mm**

Suitable for: Air suspension series **U, MT, M, EO** with single leaf trailing arm (**EN**) and

Air suspension series **U, M** with double leaf trailing arm (**S**)

Air bags with diameter **Ø 300 mm** and **Ø 350 mm**

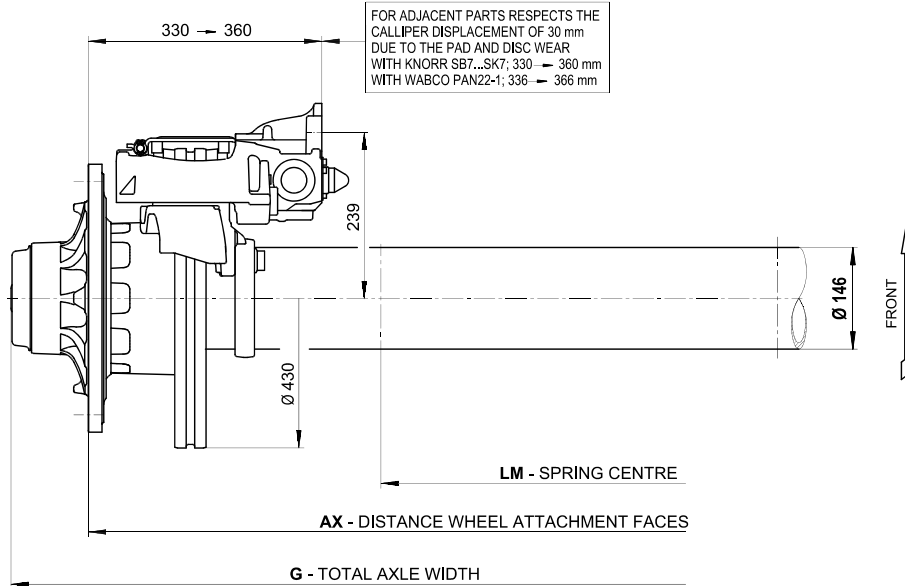

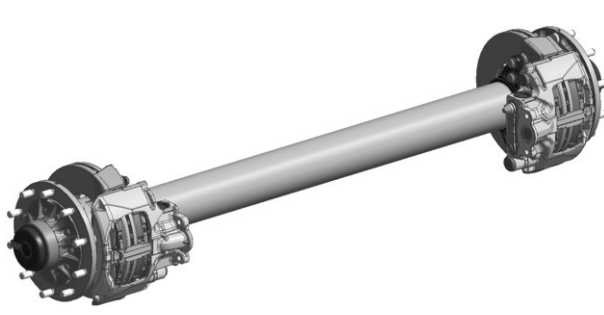
axle version / axle type / brake / test report	AX <sup>1)</sup> / LM [mm]	G [mm]	weight approx. <sup>2)</sup> [kg]
 <p><b>S19-22K01</b> / SBK2243- / KNORR, SB7...SK7 / 36110303  <b>S19-22W</b> / SBW2243-11S / WABCO, PAN22-1 / 36110702</p>	tyre (example): 385/65R22,5"		
	1970/1100	2192	305
	1970/1200 <sup>3,5)</sup>	2192	305
	2040/1200	2262	308
	2040/1300 <sup>4,5)</sup>	2262	308
	2090/1300 <sup>3,5)</sup>	2312	310
	2140/1300	2362	312
2140/1400 <sup>4,5)</sup>	2362	312	

1) **AX = S**

2) without spring seats, brake chambers and wheel nuts (spring seats are enclosed in the air suspension). weight deviations lie within the permitted DIN Tolerances for the respective manufacturing process.

3) with tyres **385/65R22,5"** and air bag diameter **Ø 350 mm** starting at **V = 30 mm**

4) with tyres **385/65R22,5"** and air bag diameter **Ø 350 mm** starting at **V = 55 mm**

5) to be combined with air suspension types starting at a nominal ride height of **330 mm**.

Note:

When choosing the suspension assembly, the clearance between air bag (max. diameter) and chosen tyre must be checked, this should be at least **25 mm**.

Further variants on request.

**Axle version ZI9-22...**

Axle load maximum **9.000 kg**

Axle beam **Ø 146 mm**

Wheel fixing: **10 / 280 / 335 / 22x1,5 mm**

Suitable for: Air suspension series **U, MT, M, EO** with single leaf trailing arm (**EN**) and

Air suspension series **U, M** with double leaf trailing arm (**S**)

Air bags with air bag diameter **Ø 300 mm** and **Ø 350 mm**

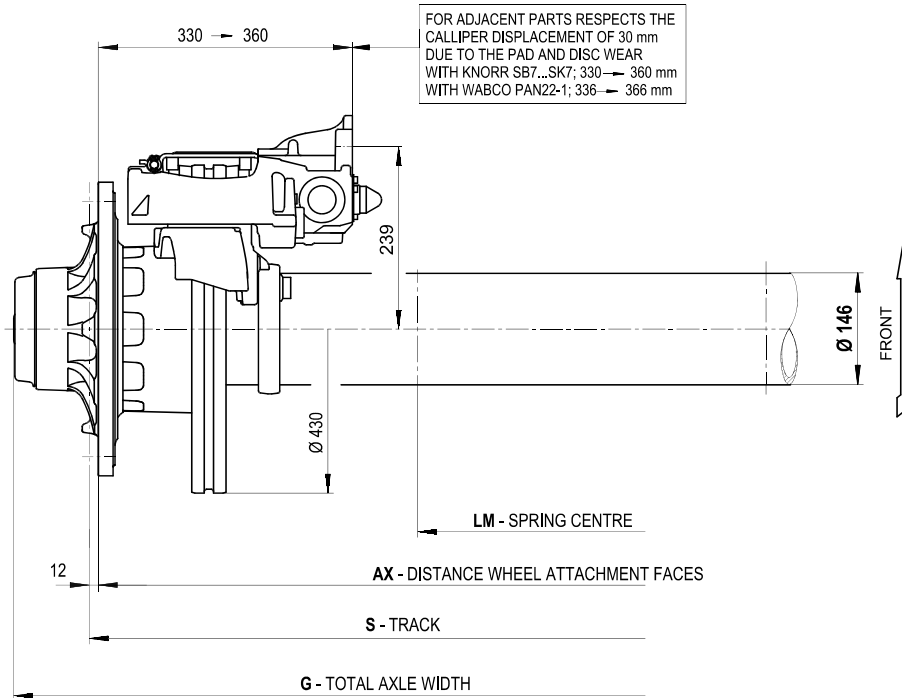

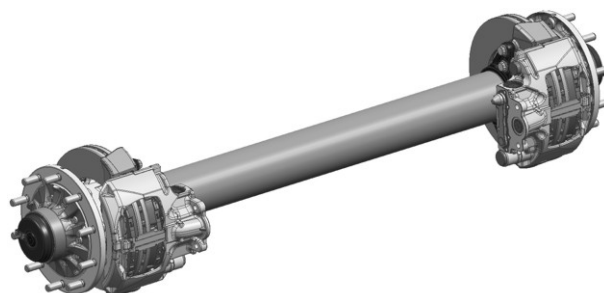
axle version / axle type / brake / test report	AX / LM [mm]	S <sup>1)</sup> / LM [mm]	G [mm]	weight approx. <sup>2)</sup> [kg]
 <b>ZI9-22K01</b> / SBK2243- / KNORR SB7...SK7 / 36110103 <b>ZI9-22W</b> / SBW2243-12,5Z / WABCO PAN22-1 / 36110602	tyre (example): 255/70R22,5"			
	1820/900 <sup>3)</sup>	1844/900 <sup>3)</sup>	2042	313
	1820/980 <sup>4)</sup>	1844/980 <sup>4)</sup>	2042	313
	1860/980 <sup>3)</sup>	1884/980 <sup>3)</sup>	2082	315

1) **S** = **AX** + 2 \* wheel disc thickness (standard 12 mm)

2) without spring seats, brake chambers and wheel nuts (spring seats are enclosed in the air suspension).  
Weight deviations lie within the permitted DIN Tolerances for the respective manufacturing process.

3) with tyres **255/70R22,5"** and air bag diameter **Ø 350 mm** starting at **V = 30 mm**

4) with tyres **255/70R22,5"** and air bag diameter **Ø 350 mm** starting at **V = 55 mm**

Note:

When choosing the suspension assembly, the clearance between air bag (max. diameter) and chosen tyre must be checked, this should be at least **25 mm**.

Further variants on request.

**Axle version SI11-22...**

Axle load maximum: **11.000 kg**

Axle beam **Ø 146 mm**

Wheel fixing: **10 / 280 / 335 / 22x1,5 mm**

Suitable for: Air suspension series **U, MT, M, EO** with single leaf trailing arm (**EN**) and  
Air suspension series **U, M** with double leaf trailing arm (**S**)  
Air bags with air bag diameter **Ø 350 mm**

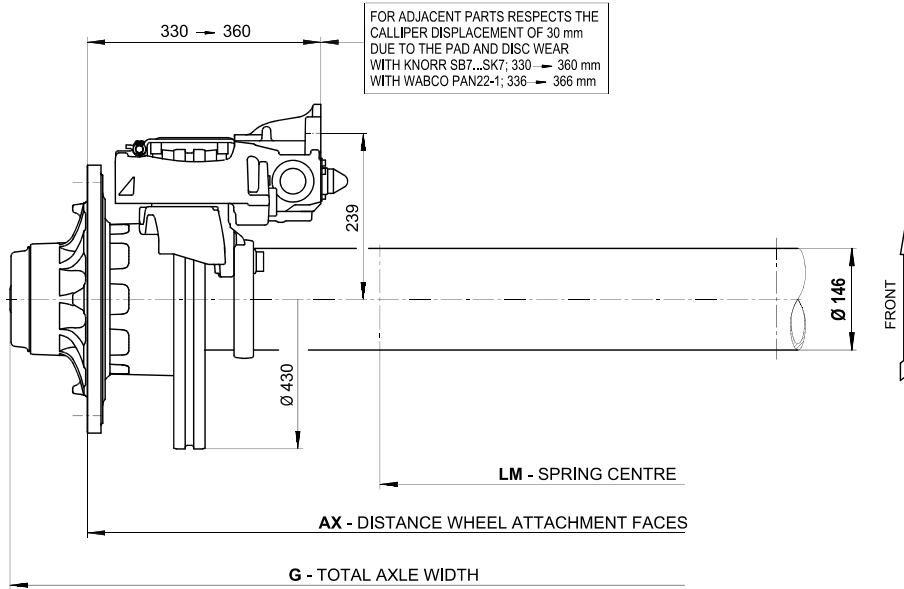

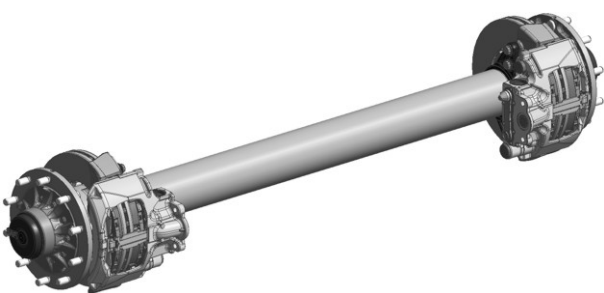
axle version / axle type / brake / test report	AX <sup>1)</sup> / LM [mm] tyre (example): 425/65R22,5"	G [mm]	weight approx. <sup>2)</sup> [kg]
 <p><b>SI11-22K01</b> / SBK2243- / KNORR SB7...SK7 / 36110203 <b>SI11-22W</b> / SBK2243-12,5S / WABCO PAN22-1 / 36109402</p>	1970/1100	2192	317
	1970/1200 <sup>4,5)</sup>	2192	317
	2040/1200 <sup>3)</sup>	2262	320
	2040/1300 <sup>4,5)</sup>	2262	320
	2090/1300 <sup>3,5)</sup>	2312	322

1) **AX = S**

2) without spring seats, brake chambers and wheel nuts (spring seats are enclosed in the air suspension).  
Weight deviations lie within the permitted DIN Tolerances for the respective manufacturing process.

3) with tyres **425/65R22,5"** and air bag diameter **Ø 350 mm** starting at **V = 30 mm**

4) with tyres **425/65R22,5"** and air bag diameter **Ø 350 mm** starting at **V = 55 mm**

5) to be combined with air suspension types starting at a nominal ride height of **330 mm**.

Note:

When choosing the suspension assembly, the clearance between air bag (max. diameter) and chosen tyre must be checked, this should be at least **25 mm**.

Further variants on request.

**Axle version ZI11-22...**

Axle load maximum: **11.000 kg**

Axle beam **Ø 146 mm**

Wheel fixing: **10 / 280 / 335 / 22x1,5 mm**

Suitable for: Air suspension series **U, M** with double leaf trailing arm (**S**)

Air bags with air bag diameter **Ø 350 mm**

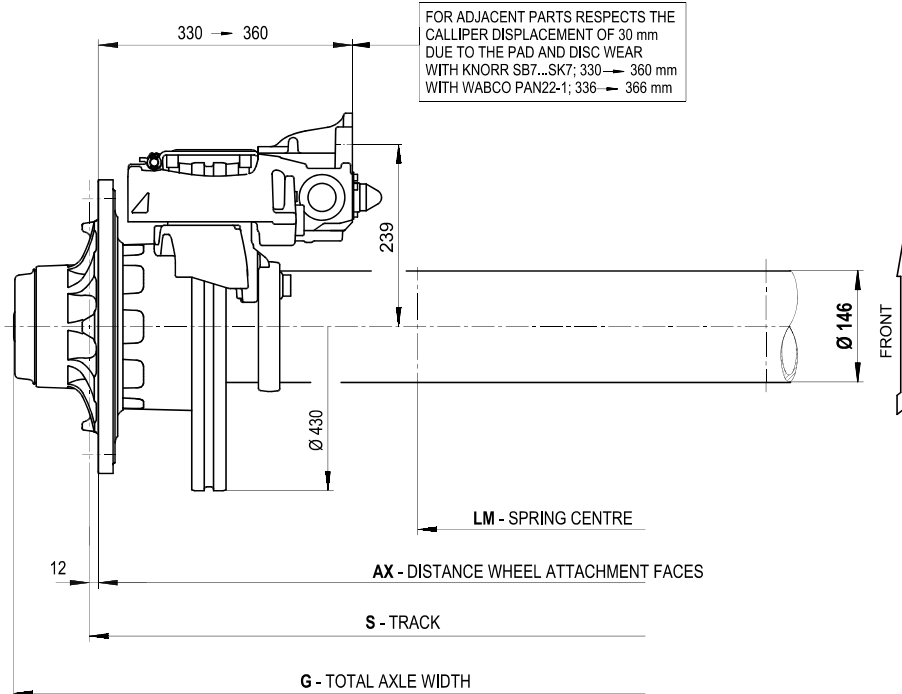

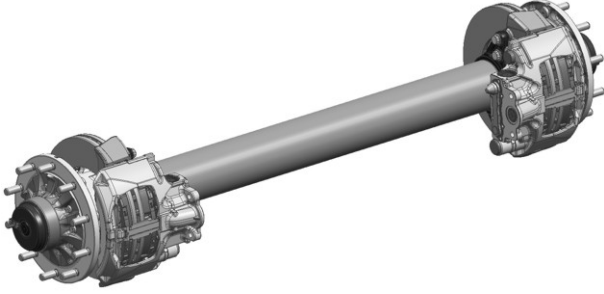
axle version / axle type / brake / test report	AX / LM	S <sup>1)</sup> / LM	G	weight approx. <sup>2)</sup>
	[mm]	[mm]		
 ZI11-22K01 / SBK2243- / KNORR SB7...SK7 / 36110103 ZI11-22W / SBW224312,5Z / WABCO PAN22-1 / 36110602	1820/900 <sup>3)</sup>	1844/900 <sup>3)</sup>	2042	315
	1820/980 <sup>5)</sup>	1844/980 <sup>5)</sup>	2042	315
	1860/980 <sup>4)</sup>	1884/980 <sup>4)</sup>	2082	317

1) **S** = **AX** + 2 \* wheel disc thickness (standard 12 mm)

2) without spring seats, brake chambers and wheel nuts (spring seats are enclosed in the air suspension).  
 Weight deviations lie within the permitted DIN Tolerances for the respective manufacturing process.

3) with tyres **275/70R22,5"** and air bag diameter **Ø 350 mm** starting at **V = 30 mm**

4) with tyres **275/70R22,5"** and air bag diameter **Ø 350 mm** starting at **V = 55 mm**

5) with tyres **275/70R22,5"** and air bag diameter **Ø 350 mm** only with **V = 70 mm**

Note:

When choosing the suspension assembly, the clearance between air bag (max. diameter) and chosen tyre must be checked, this should be at least **25 mm**.

Further variants on request.



**Axle version SIL9-22...**

Axle load maximum: **9.000 kg**

Axle beam **Ø 146 mm**

Wheel fixing: **10 / 280 / 335 / 22x1,5 mm**

Suitable for: Air suspension series **MT, M, EO** with single leaf trailing arm (**EN**) and

Air suspension series **M** with double leaf trailing arm (**S**)

Air bags with air bag diameter **Ø 300 mm** and **Ø 350 mm**

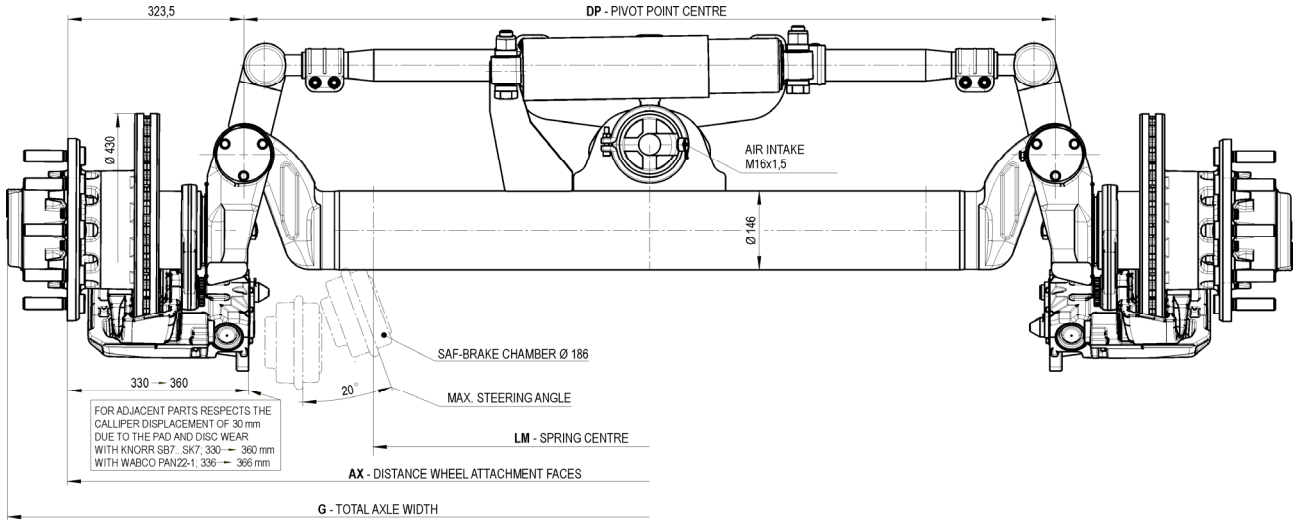

axle version / axle type / brake / test report	AX <sup>1)</sup> / LM [mm] tyre (example): 385/65R22,5"	G [mm]	DP [mm]	weight approx. <sup>2)</sup> [kg]
<p><b>SIL9-22K01 / SBK2243- / KNORR, SB7...SK7 / 36110303</b>  <b>SIL9-22W / SBW2243-11S / WABCO, PAN22-1 / 36110702</b></p>	1970/840	2192	1323	465
	2040/900	2262	1393	468
	2090/960	2312	1443	470
	2140/1000	2362	1493	472

1) **AX = S**

2) without spring seats, brake chambers and wheel nuts (spring seats are enclosed in the air suspension).  
Weight deviations lie within the permitted DIN Tolerances for the respective manufacturing process.

Note:

When choosing the suspension assembly, the clearance between air bag (max. diameter) and chosen tyre must be checked, this should be at least **25 mm**.

**All variants on request.**

**Air suspension serie U;**  
**Single leaf trailing arm (EN) 51 mm with air bag 2618V (29) or 2923V (31)**  
Nominal ride heights 200 – 365 mm

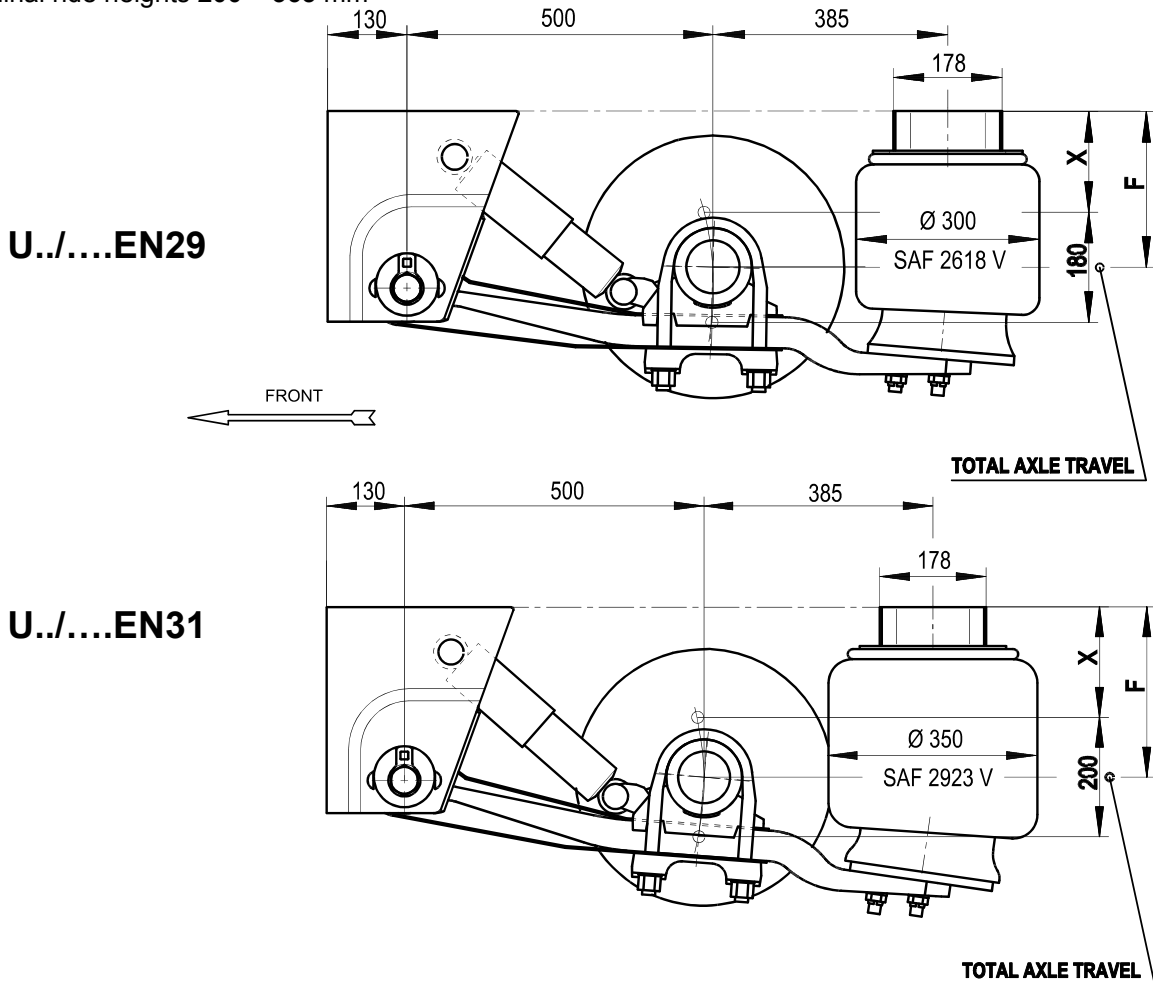

air suspension type	F; nominal ride height [mm]	for axles with an axle beam 146 mm				for axles with an axle beam 127 mm			
		ride height range [mm]	X; overall height <sup>1)</sup> unladen without air [mm]	laden without air [mm]	weight approx. <sup>2)</sup> [kg]	ride height range [mm]	X; overall height <sup>1)</sup> unladen without air [mm]	laden without air [mm]	weight approx. <sup>2)</sup> [kg]
U20/2500EN29	200	180-220	110	95	171	185-225	115	100	170
U22/2504EN29	220	200-240	130	115	172	205-245	135	120	171
U24/2904EN29	240	220-260	150	135	175	225-265	155	140	174
U25/2907EN29	255	235-275	165	150	176	240-280	170	155	175
U27/2910EN29	270	250-290	180	165	177	255-295	185	170	176
U30/3510EN29	300	280-320	210	195	182	285-325	215	200	181
U31/3513EN29	315	295-335	225	210	183	300-340	230	215	182
U33/3516EN29	330	310-350	240	225	184	315-355	245	230	183
U23/2500EN31	230	200-260	130	115	186	210-270	140	125	185
U25/2504EN31	250	220-280	150	135	187	230-290	160	145	186
U27/2904EN31	270	240-300	170	155	190	250-310	180	165	189
U28/2907EN31	285	255-315	185	170	191	265-325	195	180	190
U30/2910EN31	300	270-330	200	185	192	280-340	210	195	191
U33/3510EN31	330	300-360	230	215	197	310-370	240	225	196
U35/3513EN31	350	320-380	250	235	198	330-390	260	245	197
U36/3516EN31	365	335-395	265	250	199	345-405	275	260	198

1) The data in the table corresponds with an air bag offset (V) of 0 or 30 mm, with V = 55 mm or V = 70 mm the overall height X is increased by 5 mm (so changes the ride height range accordantly)

2) Weight deviations lie within the permitted DIN Tolerances for the respective manufacturing process.

Further variants on request.

**Air suspension serie M;  
Single leaf trailing arm (EN) 51 mm with air bag 2618V (29) or 2923V (31)**  
Nominal ride heights 365 – 500 mm

**M../....EN29**

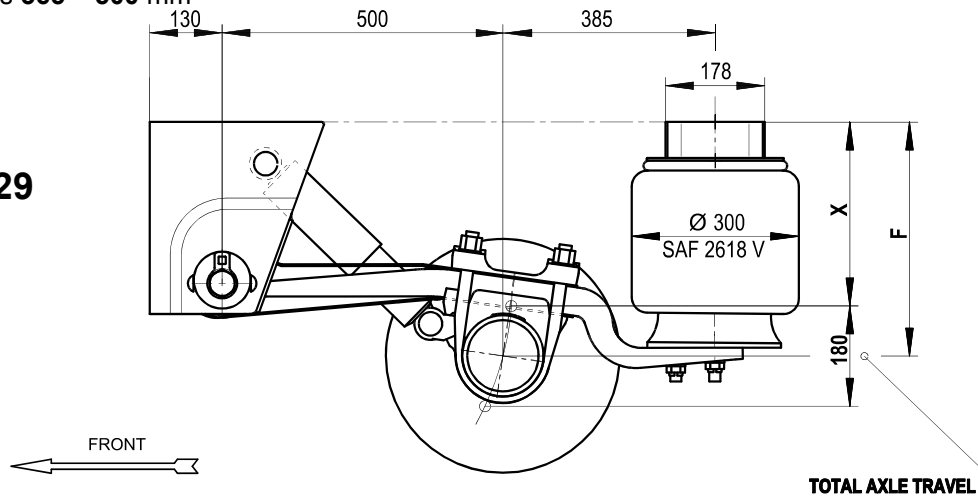

**M../....EN31**

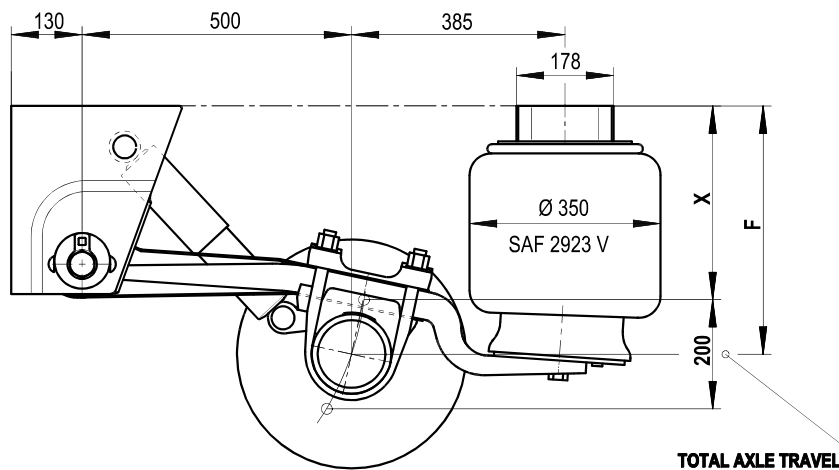

air suspension type	F; nominal ride height [mm]	for axles with an axle beam 146 mm				for axles with an axle beam 127 mm			
		ride height range [mm]	X; overall height <sup>1)</sup> unladen without air [mm]	laden without air [mm]	weight approx. <sup>2)</sup> [kg]	ride height range [mm]	X; overall height <sup>1)</sup> unladen without air [mm]	laden without air [mm]	weight approx. <sup>2)</sup> [kg]
M36/2500EN29	365	345-385	275	260	174	335-375	265	250	173
M38/2504EN29	385	365-405	295	280	175	355-395	285	270	174
M40/2904EN29	400	380-420	310	295	178	370-410	300	285	177
M42/2907EN29	420	400-440	330	315	179	390-430	320	305	178
M43/2910EN29	435	415-455	345	330	180	405-445	335	320	179
M46/3510EN29	465	445-485	375	360	185	435-475	365	350	184
M40/2500EN31	400	370-430	300	285	189	360-420	290	275	188
M42/2504EN31	420	390-450	320	305	190	380-440	310	295	189
M43/2904EN31	435	405-465	335	320	193	395-455	325	310	192
M45/2907EN31	455	425-485	355	340	194	415-475	345	330	193
M47/2910EN31	470	440-500	370	355	195	430-490	360	345	194
M50/3510EN31	500	470-530	400	385	200	460-520	390	375	199

1) The data in the table corresponds with an air bag offset (V) of 0 or 30 mm, with V = 55 mm or V = 70 mm the overall height X is increased by 5 mm (so changes the ride height range accordantly)

2) Weight deviations lie within the permitted DIN Tolerances for the respective manufacturing process.

Further variants on request.

**Air suspension serie EO;**  
**Single leaf trailing arm (EN) 51 mm with air bag 2618V (29) or 2923V (31)**  
Nominal ride heights 410 – 545 mm

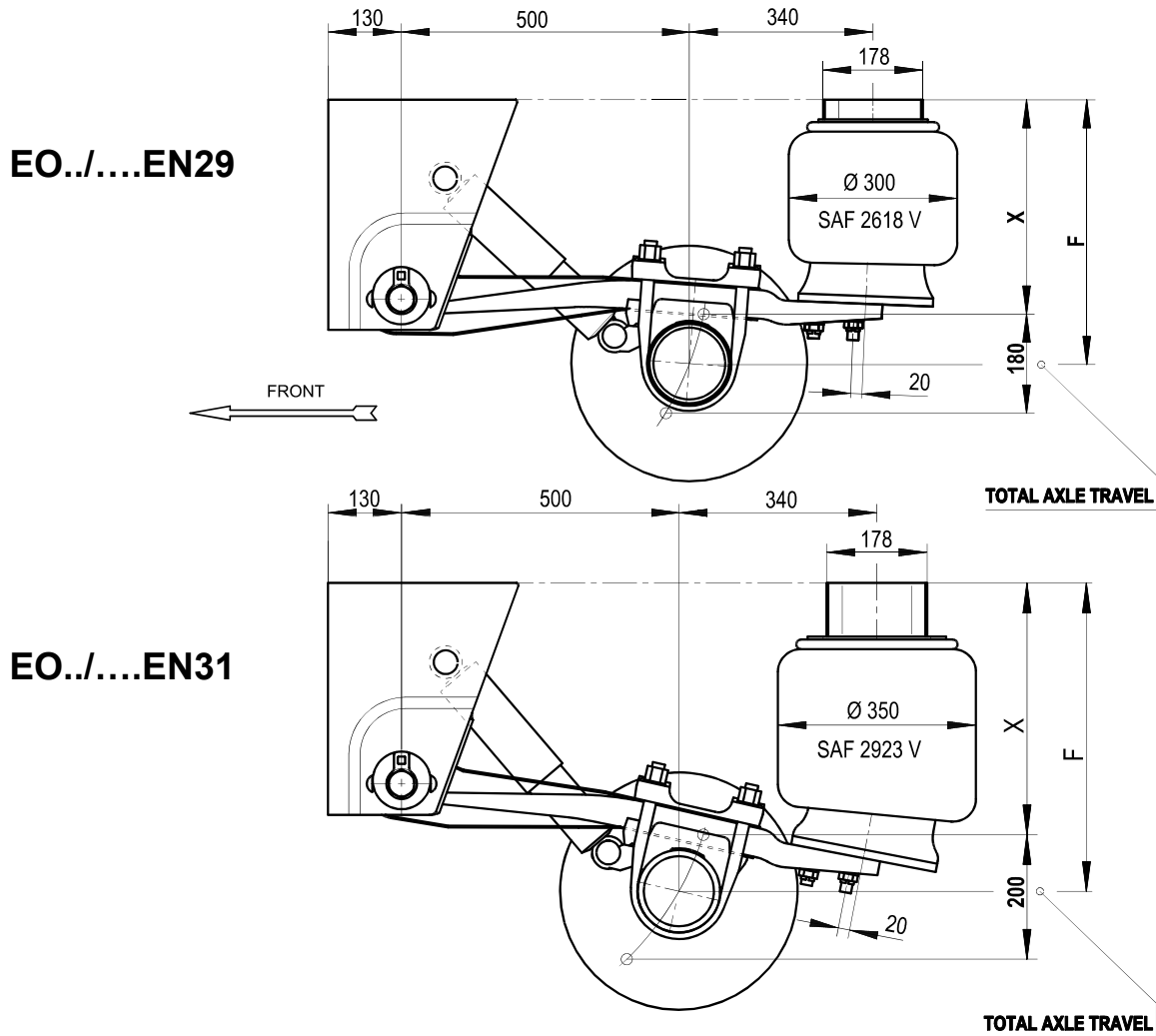

air suspension type	F; nominal ride height [mm]	for axles with axle beam 146 mm				for axles with axle beam 127 mm			
		ride height range [mm]	X; overall height unladen without air [mm]	X; overall height laden without air [mm]	weight approx. <sup>2)</sup> [kg]	ride height range [mm]	X; overall height unladen without air [mm]	X; overall height laden without air [mm]	weight approx. <sup>2)</sup> [kg]
EO41/2500EN29	410	395-435	330	315	173	385-425	320	305	172
EO42/2900EN29	425	415-455	345	330	176	405-445	335	320	175
EO44/2904EN29	445	435-475	365	350	177	425-465	355	340	176
EO47/3504EN29	470	460-500	390	375	182	450-490	380	365	181
EO49/3507EN29	490	480-520	410	395	183	470-510	400	385	182
EO50/3510EN29	505	495-535	425	410	184	485-525	415	400	183
EO44/2500EN31	445	425-485	355	340	188	415-475	345	330	187
EO46/2900EN31	460	440-500	370	355	191	430-490	360	345	190
EO48/2904EN31	480	460-520	390	375	192	450-510	380	365	191
EO50/3504EN31	505	485-545	415	400	197	475-535	405	390	196
EO52/3507EN31	525	505-565	435	420	198	495-555	425	410	197
EO54/3510EN31	545	525-585	455	440	199	515-575	445	430	198

1) The data in the table corresponds with an air bag offset (V) of 0, 30, 55 or 70 mm.

2) Weight deviations lie within the permitted DIN Tolerances for the respective manufacturing process.

Further variants on request.

**Air suspension serie U;  
Double leaf trailing arm (S) 43/43 mm with air bag 2918V (27) or 2923V (31)**

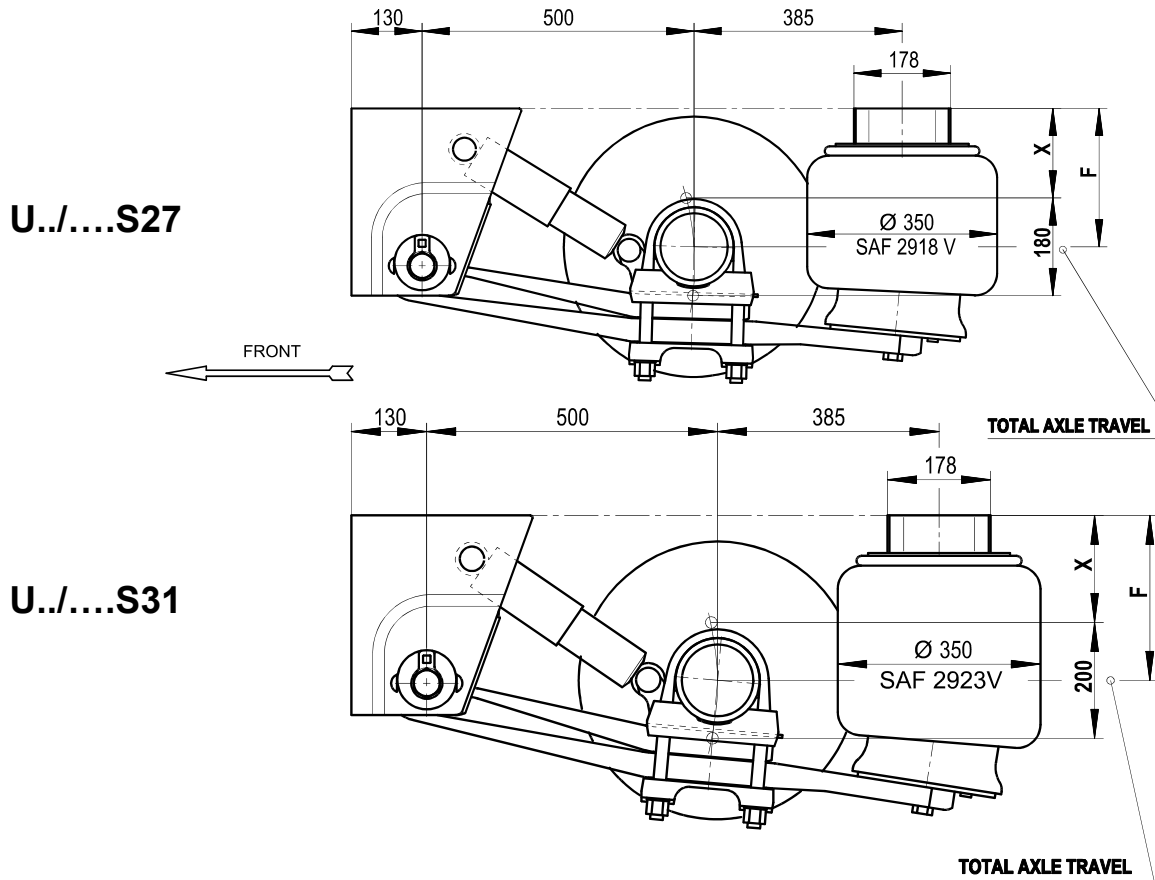

air suspension type	F; nominal ride height [mm]	for axles with axle beam 146 mm				for axles with axle beam 127 mm			
		ride height range [mm]	X; overall height <sup>1)</sup> unladen without air [mm]	laden without air [mm]	weight approx. <sup>2)</sup> [kg]	ride height range [mm]	X; overall height <sup>1)</sup> unladen without air [mm]	laden without air [mm]	weight approx. <sup>2)</sup> [kg]
U20/2500S27	200	180-220	110	100	203	190-230	120	110	202
U22/2504S27	220	200-240	130	120	204	210-250	140	130	203
U24/2904S27	240	220-260	150	140	207	230-270	160	150	206
U25/2907S27	255	235-275	165	155	208	245-285	175	165	207
U27/2910S27	270	250-290	180	170	209	260-300	190	180	208
U30/3510S27	300	280-320	210	200	214	290-330	220	210	213
U31/3513S27	315	295-335	225	215	215	305-345	235	225	214
U33/3516S27	330	310-350	240	230	216	320-360	250	240	215
U23/2500S31	230	205-265	135	125	205	215-275	145	135	204
U25/2504S31	250	225-285	155	145	206	235-295	165	155	205
U27/2904S31	270	245-305	175	165	209	255-315	185	175	208
U28/2907S31	285	260-320	190	180	210	270-330	200	190	209
U30/2910S31	300	275-335	205	195	211	285-345	215	205	210
U33/3510S31	330	305-365	235	225	216	315-375	245	235	215
U35/3513S31	350	325-385	255	245	217	335-395	265	255	216
U36/3516S31	365	340-400	270	260	218	350-410	280	270	217

1) The data in the table corresponds with an air bag offset (V) of 0 or 30 mm, with V = 55 mm or V = 70 mm the overall height X is increased by 5 mm (so changes the ride height range accordantly)

2) Weight deviations lie within the permitted DIN Tolerances for the respective manufacturing process.

Further variants on request.

**Air suspension serie M;  
Double leaf trailing arm (S) 43/43 mm with air bag 2918V (27) or 2923V (31)**

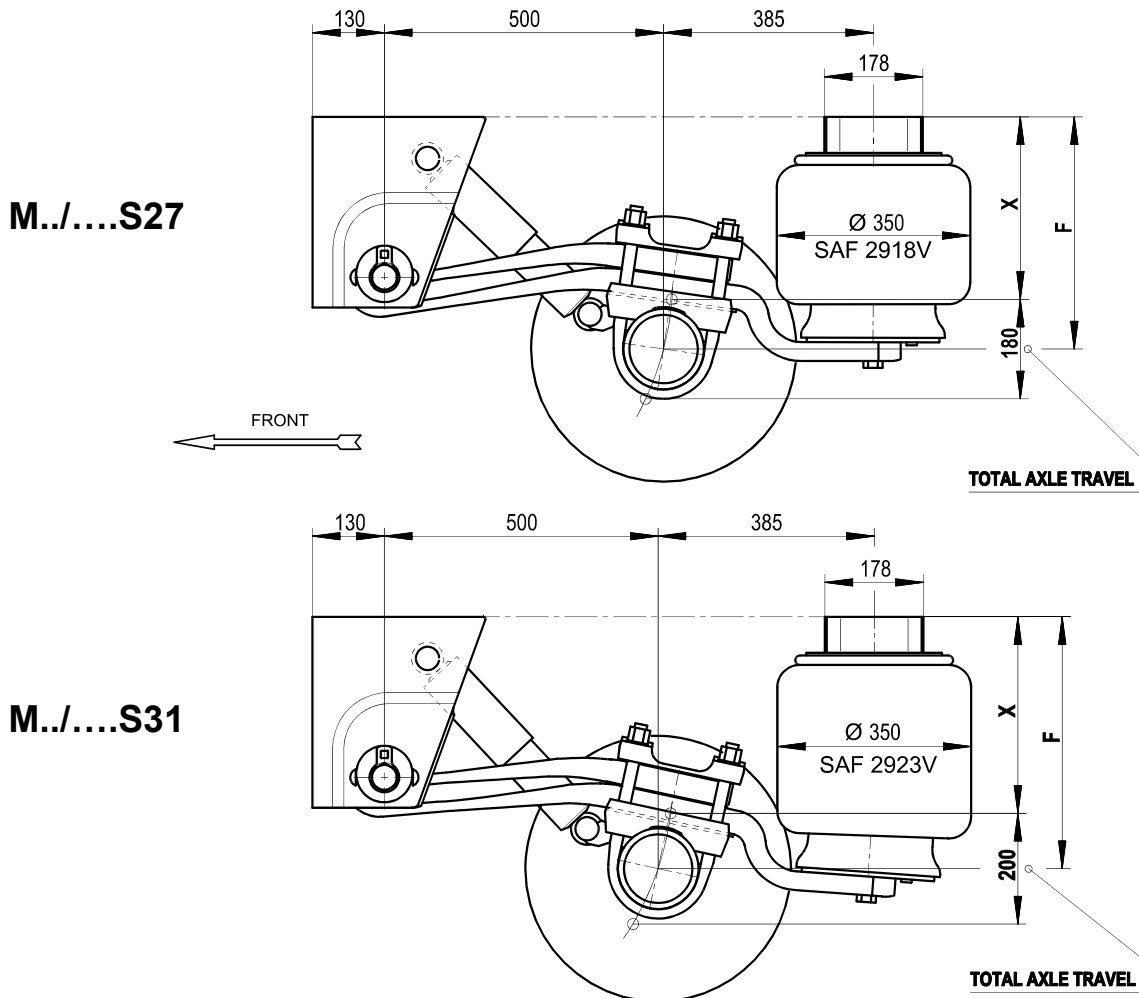

air suspension type	F; nominal ride height [mm]	for axles with axle beam 146 mm				for axles with axle beam 127 mm			
		ride height range [mm]	X; overall height <sup>1)</sup> unladen without air [mm]	laden without air [mm]	weight approx. <sup>2)</sup> [kg]	ride height range [mm]	X; overall height <sup>1)</sup> unladen without air [mm]	laden without air [mm]	weight approx. <sup>2)</sup> [kg]
M36/2500S27	365	350-390	280	270	209	340-380	270	260	208
M38/2504S27	385	370-410	300	290	210	360-400	290	280	209
M40/2904S27	400	385-425	315	305	213	375-415	305	295	212
M42/2907S27	420	405-445	335	325	214	395-435	325	315	213
M43/2910S27	435	420-460	350	340	215	410-450	340	330	214
M46/3510S27	465	450-490	380	370	220	440-480	370	360	219
M40/2500S31	400	375-435	305	295	211	365-425	295	285	210
M42/2504S31	420	395-455	325	315	212	385-445	315	305	211
M43/2904S31	435	410-470	340	330	215	400-460	330	320	214
M45/2907S31	455	430-490	360	350	216	420-480	350	340	215
M47/2910S31	470	445-505	375	365	217	435-495	365	355	216
M50/3510S31	500	475-535	405	395	222	465-525	395	385	221

1) The data in the table corresponds with an air bag offset (V) of 0 or 30 mm, with V = 55 mm or V = 70 mm the overall height X is increased by 5 mm (so changes the ride height range accordantly)

2) Weight deviations lie within the permitted DIN Tolerances for the respective manufacturing process.

Further variants on request.

**Axle version S7-3015**

Axle load maximum: **7.000 kg**

Axle beam **Ø 127 mm**

Wheel fixing: **10 / 175 / 225 / 22x1,5 mm**

Suitable for: Air suspension series **U, M, EO** with single leaf trailing arm (**EN**) and  
Air bags with air bag diameter **Ø 300 mm**

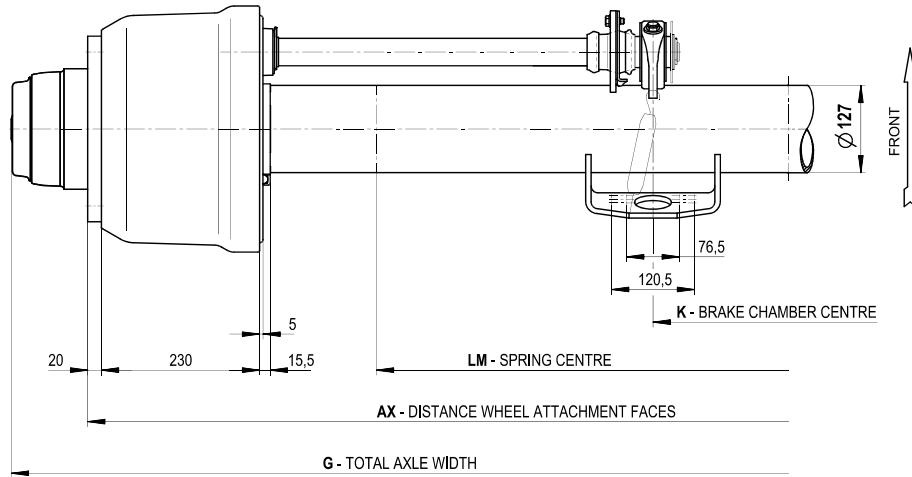

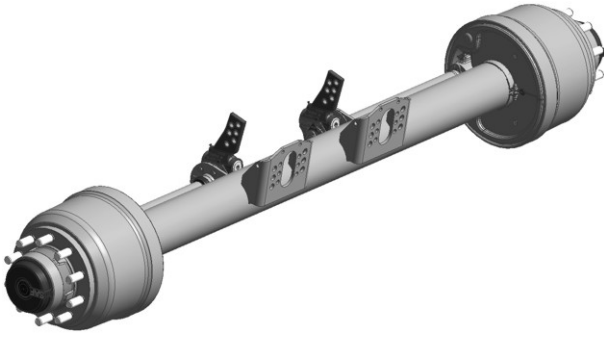
axle version / axle type / brake / test report	AX <sup>1)</sup> / LM [mm] tyre (example) 285/70R19,5"	G [mm]	K [mm]	weight approx. <sup>2)</sup> [kg]
 <p><b>S7-3015 / SNK3015-9S / SNK300x150 / TDB0622</b></p>	1970/1200	2192	325	267
	2040/1200	2262	395	269
	2040/1300	2262	395	269
	2090/1300	2312	445	271
	2140/1300	2362	495	273
	2140/1400	2362	495	273
	2200/1460	2422	555	275

1) **AX = S**

2) without spring seats, slack adjuster and wheel nuts (spring seats are enclosed in the air suspension).  
Weight deviations lie within the permitted DIN Tolerances for the respective manufacturing process.

Note:

When choosing the suspension assembly, the clearance between air bag (max. diameter) and chosen tyre must be checked, this should be at least **25 mm**.

Further variants on request.



**Axle version Z7-3015**

Axle load maximum: **7.000 kg**

Axle beam **Ø 127 mm**

Wheel fixing: **10 / 175 / 225 / 22x1,5 mm**

Suitable for: Air suspension series **U, M, EO** with single leaf trailing arm (**EN**) and Air bags with air bag diameter **Ø 300 mm**

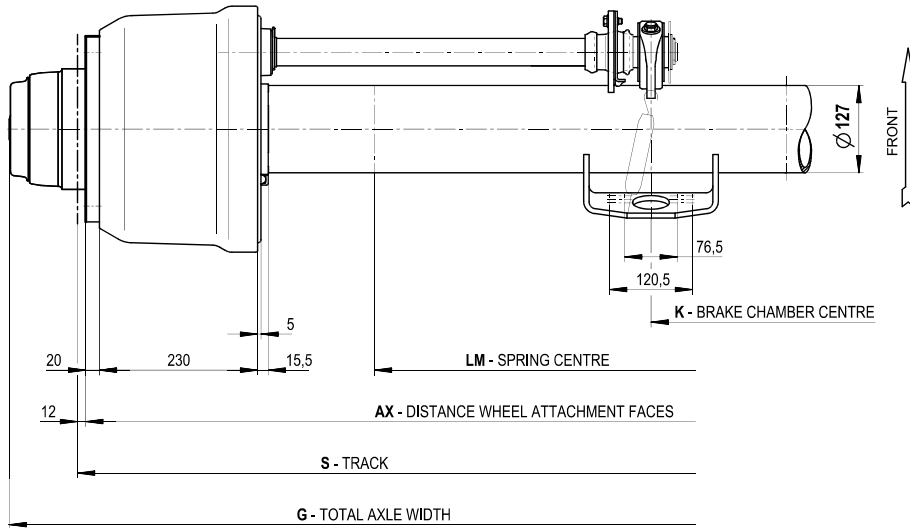

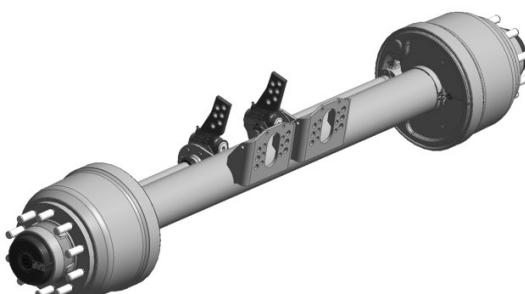
axle version / axle type / brake / test report	AX / LM	S <sup>1)</sup> / LM	G	K	Weight approx. <sup>2)</sup>
	[mm]	[mm]	[mm]	[mm]	[kg]
 <p><b>Z7-3015 / SNK3015-9Z / SNK 300x150 / TDB0623</b></p>	tyre (example): 205/65R17,5"				
	1806/900	1830/900	2028	232	260
	1806/980 <sup>3)</sup>	1830/980 <sup>3)</sup>	2028	232	260
	1860/980	1884/980	2082	286	262
	1860/1050 <sup>3)</sup>	1884/1050 <sup>3)</sup>	2082	286	262
	1926/1050	1950/1050	2148	352	264
	1926/1100 <sup>3)</sup>	1950/1100 <sup>3)</sup>	2148	352	264
	1970/1100	1994/1100	2193	396	266
	1970/1150 <sup>3)</sup>	1994/1150 <sup>3)</sup>	2193	396	266

1) **S = AX + 2 \* wheel disc thickness (standard 12 mm)**

2) without spring seats, slack adjuster and wheel nuts (spring seats are enclosed in the air suspension).  
Weight deviations lie within the permitted DIN Tolerances for the respective manufacturing process.

3) with tyres **205/65R17,5"** and air bag diameter **Ø 350 mm** starting at **V = 30 mm**

Note:

When choosing the suspension assembly, the clearance between air bag (max. diameter) and chosen tyre must be checked, this should be at least **25 mm**.

Further variants on request.



**Axle version Z9-3020**

Axle load maximum: **9.000 kg**

Axle beam **Ø 127 mm**

Wheel fixing: **10 / 175 / 225 / 22x1,5 mm**

Suitable for: Air suspension series **U, M, EO** with single leaf trailing arm (**EN**) and

Air suspension series **U, M** with double leaf trailing arm (**S**)

Air bags with air bag diameter **Ø 300 mm** and **Ø 350 mm**

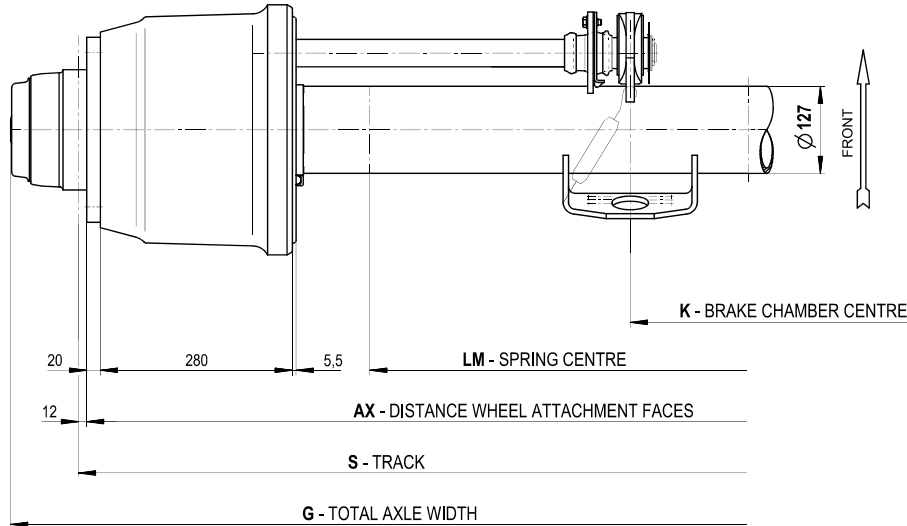

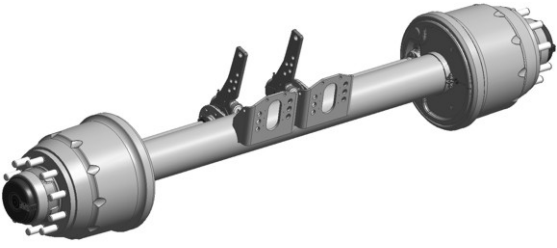
axle version / axle type / brake / test report	AX <sup>1)</sup> / LM	S / LM	G	K	weight approx. <sup>2)</sup>
	[mm]	[mm]	[mm]	[mm]	[kg]
 <p><b>Z9-3020 / SNK3020-13Z / SNK300x200 / TDB0487</b></p>	1806/900 <sup>3)</sup>	1830/900 <sup>3)</sup>	2028	220	305
	1806/980 <sup>4)</sup>	1830/980 <sup>4)</sup>	2028	220	305
	1860/980 <sup>3)</sup>	1884/980 <sup>3)</sup>	2082	220	307,5
	1860/1050 <sup>4)</sup>	1884/1050 <sup>4)</sup>	2082	220	307,5
	1926/1050 <sup>3)</sup>	1950/1050 <sup>3)</sup>	2148	340	311
	1926/1100 <sup>4)</sup>	1950/1100 <sup>4)</sup>	2148	340	311
	1971/1100 <sup>3)</sup>	1995/1100 <sup>3)</sup>	2193	385	314
	1971/1150 <sup>4)</sup>	1995/1150 <sup>4)</sup>	2193	385	314

- 1) **S = AX + 2 \* wheel disc thickness** (standard 12 mm)
- 2) without spring seats, slack adjuster and wheel nuts (spring seats are enclosed in the air suspension).  
Weight deviations lie within the permitted DIN Tolerances for the respective manufacturing process.
- 3) with tyres **235/75R17,5"** and air bag diameter **Ø 350 mm** starting at **V = 30 mm**
- 4) with tyres **235/75R17,5"** and air bag diameter **Ø 350 mm** starting at **V = 55 mm**

Note:  
When choosing the suspension assembly, the clearance between air bag (max. diameter) and chosen tyre must be checked, this should be at least **25 mm**.

Further variants on request.

**Axle version Z11-3020**

Axle load maximum: **11.000 kg**

Axle beam **Ø 127 mm**

Wheel fixing: **10 / 175 / 225 / 22x1,5 mm**

Suitable for: Air suspension series **U, M** with double leaf trailing arm (**S**)

Air bags with air bag diameter **Ø 350 mm**

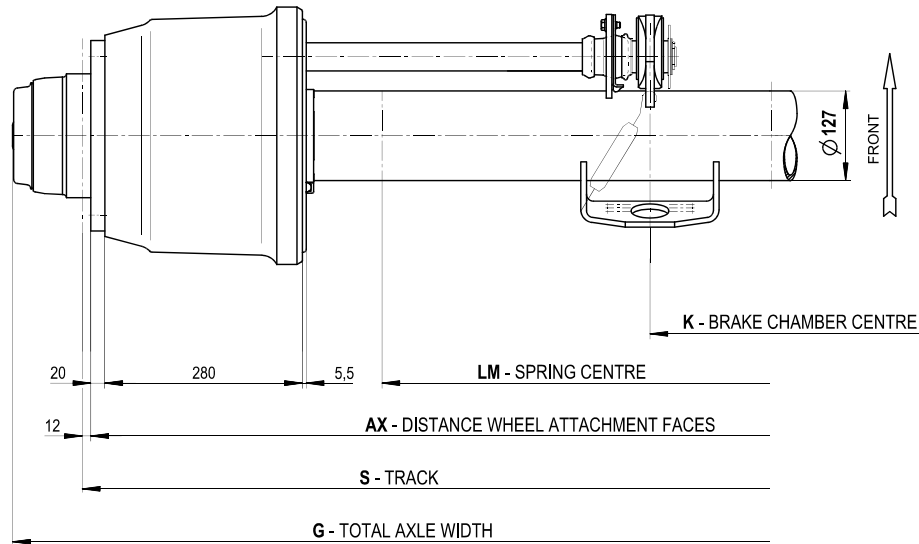

axle version / axle type / brake / test report	AX <sup>1)</sup> / LM	S / LM	G	K	weight approx. <sup>2)</sup>
	[mm]	[mm]	[mm]	[mm]	[kg]
 <p><b>Z11-3020 / SNK3020-13Z / SNK300x200 / TDB0487</b></p>	tyre (example): 235/75R17,5"				
	1806/900 <sup>3)</sup>	1830/900 <sup>3)</sup>	2028	220	305
	1806/980 <sup>4)</sup>	1830/980 <sup>4)</sup>	2028	220	305
	1860/980 <sup>3)</sup>	1884/980 <sup>3)</sup>	2082	220	307,5
	1860/1050 <sup>4)</sup>	1884/1050 <sup>4)</sup>	2082	220	307,5
	1926/1050 <sup>3)</sup>	1950/1050 <sup>3)</sup>	2148	340	311
	1926/1100 <sup>4)</sup>	1950/1100 <sup>4)</sup>	2148	340	311
	1971/1100 <sup>3)</sup>	1995/1100 <sup>3)</sup>	2193	385	314
1971/1150 <sup>4)</sup>	1995/1150 <sup>4)</sup>	2193	385	314	

- 1) **S = AX + 2 \* wheel disc thickness (standard 12 mm)**
- 2) without spring seats, slack adjuster and wheel nuts (spring seats are enclosed in the air suspension).  
Weight deviations lie within the permitted DIN Tolerances for the respective manufacturing process.
- 3) with tyres **235/75R17,5"** and air bag diameter **Ø 350 mm** starting at **V = 30 mm**
- 4) with tyres **235/75R17,5"** and air bag diameter **Ø 350 mm** starting at **V = 55 mm**

Note:  
When choosing the suspension assembly, the clearance between air bag (max. diameter) and chosen tyre must be checked, this should be at least **25 mm**.

Further variants on request.

**Axle version SK RZ 12030**

Axle load maximum: **12.000 kg**

Axle beam **Ø 127 mm**

Wheel fixing: **10 / 175 / 225 / 22x1,5 mm**

Suitable for: Air suspension series **U, M** with double leaf trailing arm (**S**)

Air bags with air bag diameter **Ø 350 mm**

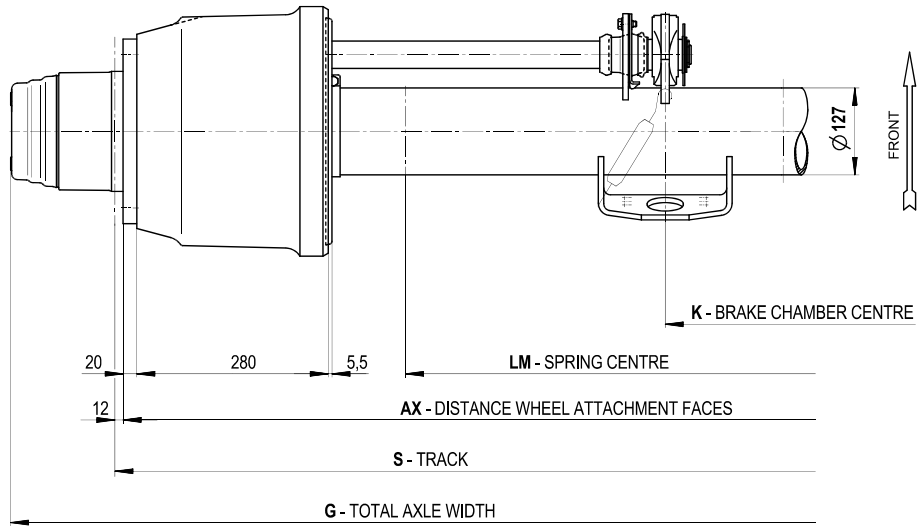

axle version / axle type / brake / test report	AX <sup>1)</sup> / LM	S / LM	G	K	weight approx. <sup>2)</sup>
	[mm]	[mm]	[mm]	[mm]	[kg]
 <b>SK RZ 12030 / SNK3020-13Z / SNK300x200 / TDB0487</b>	1806/900 <sup>3)</sup>	1830/900 <sup>3)</sup>	2028	220	320
	1806/980 <sup>4)</sup>	1830/980 <sup>4)</sup>	2028	220	320
	1860/980 <sup>3)</sup>	1884/980 <sup>3)</sup>	2082	220	322,5
	1860/1050 <sup>4)</sup>	1884/1050 <sup>4)</sup>	2082	220	322,5
	1926/1050 <sup>3)</sup>	1950/1050 <sup>3)</sup>	2148	340	326
	1926/1100 <sup>4)</sup>	1950/1100 <sup>4)</sup>	2148	340	326
	1971/1100 <sup>3)</sup>	1995/1100 <sup>3)</sup>	2193	385	329
	1971/1150 <sup>4)</sup>	1995/1150 <sup>4)</sup>	2193	385	329

1) **S** = **AX** + 2 \* wheel disc thickness (standard 12 mm)

2) without spring seats, slack adjuster and wheel nuts (spring seats are enclosed in the air suspension). Weight deviations lie within the permitted DIN Tolerances for the respective manufacturing process.

3) with tyres **235/75R17,5"** and air bag diameter **Ø 350 mm** starting at **V = 30 mm**

4) with tyres **235/75R17,5"** and air bag diameter **Ø 350 mm** starting at **V = 55 mm**

Note:

When choosing the suspension assembly, the clearance between air bag (max. diameter) and chosen tyre must be checked, this should be at least **25 mm**.

Further variants on request.

**Axle version S9-3718**

Axle load maximum: **9.000 kg**

Axle beam  $\varnothing$  **127 mm**

Wheel fixing: **8 / 220 / 275 / 22x1,5 mm** or **10 / 280 / 335 / 22x1,5 mm**

Suitable for: Air suspension series **U, M, EO** with single leaf trailing arm (**EN**) and

Air suspension series **U, M** with double leaf trailing arm (**S**)

Air bags with air bag diameter  $\varnothing$  **300 mm** and  $\varnothing$  **350 mm**

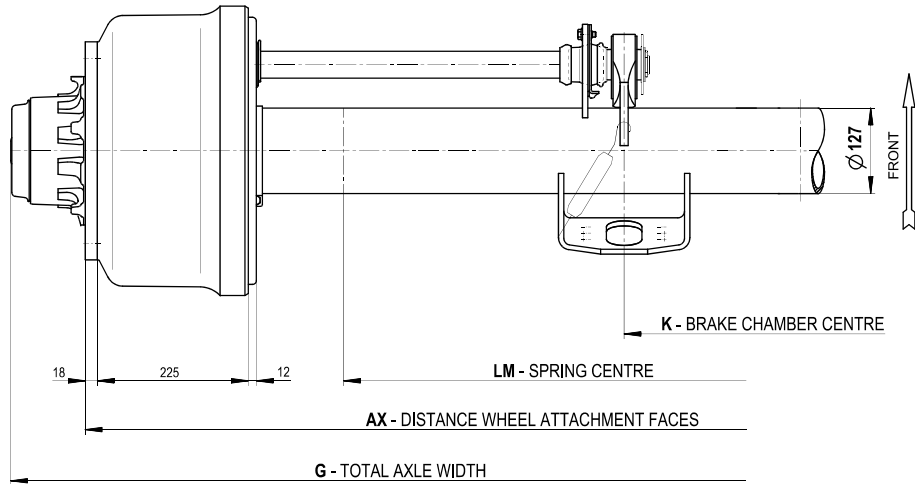

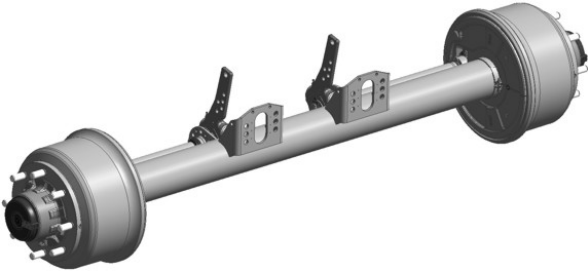
axle version / axle type / brake / test report	AX <sup>1)</sup> / LM [mm] tyre (example): 425/55R19,5"	G [mm]	K [mm]	weight approx. <sup>2)</sup> [kg]
 <b>S9-3718 / SNK3718-11S / SNK367x180 / TDB0459</b>	1970/1100	2192	364	302
	1970/1200 <sup>4)</sup>	2192	364	302
	2040/1200	2262	434	305
	2040/1300 <sup>4)</sup>	2262	434	305
	2090/1300 <sup>3)</sup>	2312	484	307

1) **AX = S**

2) without spring seats, slack adjuster and wheel nuts (spring seats are enclosed in the air suspension).  
Weight deviations lie within the permitted DIN Tolerances for the respective manufacturing process.

3) with tyres **425/55R19,5"** and air bag diameter  $\varnothing$  **350 mm** starting at **V = 30 mm**

4) with tyres **425/55R19,5"** and air bag diameter  $\varnothing$  **350 mm** starting at **V = 55 mm**

Note:

When choosing the suspension assembly, the clearance between air bag (max. diameter) and chosen tyre must be checked, this should be at least **25 mm**.

Further variants on request.

**Axle version Z9-3720**

Axle load maximum: **9.000 kg**

Axle beam **Ø 127 mm**

Wheel fixing: **8 / 220 / 275 / 22x1,5 mm** or **10 / 175 / 225 / 22x1,5 mm**

Suitable for: Air suspension series **U, M, EO** with single leaf trailing arm (**EN**) and

Air suspension series **U, M** with double leaf trailing arm (**S**)

Air bags with air bag diameter **Ø 300 mm** and **Ø 350 mm**

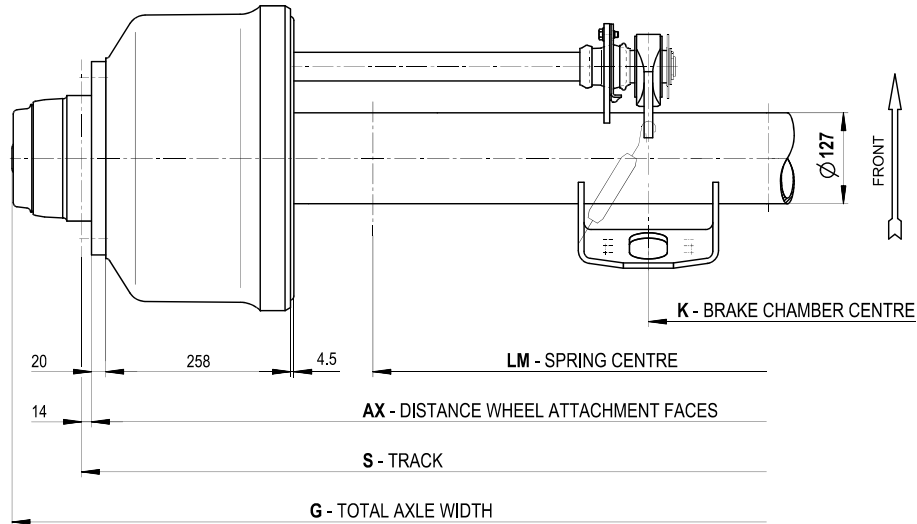

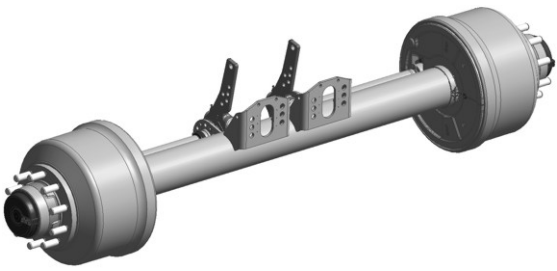
axle version / axle type / brake / test report	AX / LM	S <sup>1)</sup> / LM	G	K	weight approx. <sup>2)</sup>
	[mm]	[mm]			
 <b>Z9-3720 / SNK3720-13Z / SNK367x200 / TDB0460</b>	tyre (example): 265/70R19,5"				
	1806/900 <sup>3)</sup>	1834/900 <sup>3)</sup>	2028	250	317
	1806/980 <sup>5)</sup>	1834/980 <sup>5)</sup>	2028	250	317
	1860/900	1888/900	2082	246	320
	1860/980 <sup>4)</sup>	1888/980 <sup>4)</sup>	2082	246	320
	1926/1050 <sup>4)</sup>	1954/1050 <sup>4)</sup>	2148	312	325
	1926/1100 <sup>5)</sup>	1954/1100 <sup>5)</sup>	2148	312	325

- 1) **S = AX + 2 \* wheel disc thickness (standard 14 mm)**
- 2) without spring seats, slack adjuster and wheel nuts (spring seats are enclosed in the air suspension). Weight deviations lie within the permitted DIN Tolerances for the respective manufacturing process.
- 3) with tyres **265/70R19,5"** and air bag diameter **Ø 350 mm** starting at **V = 30 mm**
- 4) with tyres **265/70R19,5"** and air bag diameter **Ø 350 mm** starting at **V = 55 mm**
- 5) with tyres **265/70R19,5"** and air bag diameter **Ø 350 mm** only with **V = 70 mm**

Note:

When choosing the suspension assembly, the clearance between air bag (max. diameter) and chosen tyre must be checked, this should be at least **25 mm**.

Further variants on request.

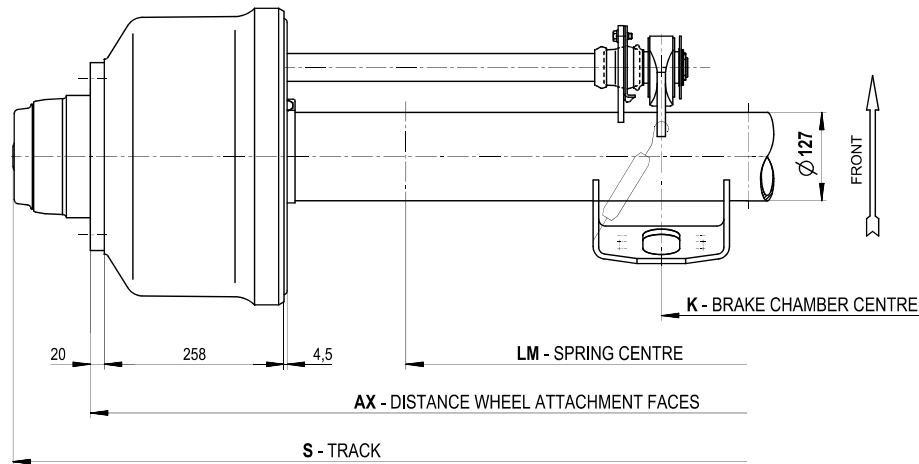
**Axle version S11-3720**Axle load maximum: **11.000 kg**Axle beam  $\varnothing$  **127 mm**Wheel fixing: **8 / 220 / 275 / 22x1,5 mm** or **10 / 280 / 335 / 22x1,5 mm**Suitable for: Air suspension series **U, M, EO** with single leaf trailing arm (**EN**) andAir suspension series **U, M** with double leaf trailing arm (**S**)Air bags with air bag diameter  $\varnothing$  **350 mm**

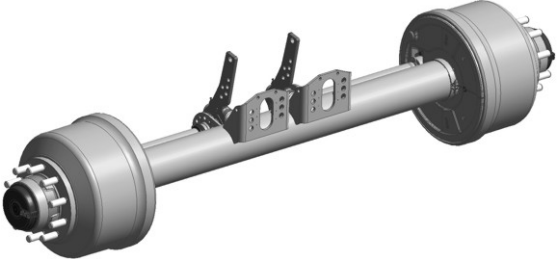
axle version / axle type / brake / test report	AX <sup>1)</sup> / LM [mm] tyre (example): 445/65R19,5"	G [mm]	K [mm]	weight approx. <sup>2)</sup> [kg]
 <b>S11-3720 / SNK3720-11S / SNK367x200 / TDB0503</b>	1970/1100 <sup>3)</sup>	2192	314	329
	1970/1200 <sup>4)</sup>	2192	314	329
	2040/1200 <sup>3)</sup>	2262	384	332
	2040/1260 <sup>4)</sup>	2262	384	332

1) **AX = S**2) without spring seats, slack adjuster and wheel nuts (spring seats are enclosed in the air suspension).  
Weight deviations lie within the permitted DIN Tolerances for the respective manufacturing process.3) with tyres **445/65R19,5"** and air bag diameter  $\varnothing$  **350 mm** starting at **V = 30 mm**4) with tyres **445/65R19,5"** and air bag diameter  $\varnothing$  **350 mm** starting at **V = 55 mm**

Note:

When choosing the suspension assembly, the clearance between air bag (max. diameter) and chosen tyre must be checked, this should be at least **25 mm**.

Further variants on request.

**Axle version Z11-3720**

Axle load maximum: **11.000 kg**

Axle beam  $\varnothing$  **127 mm**

Wheel fixing: **8 / 220 / 275 / 22x1,5 mm** or **10 / 175 / 225 / 22x1,5 mm**

Suitable for: Air suspension series **U, M** with double leaf trailing arm (**S**)

Air bags with air bag diameter  $\varnothing$  **350 mm**

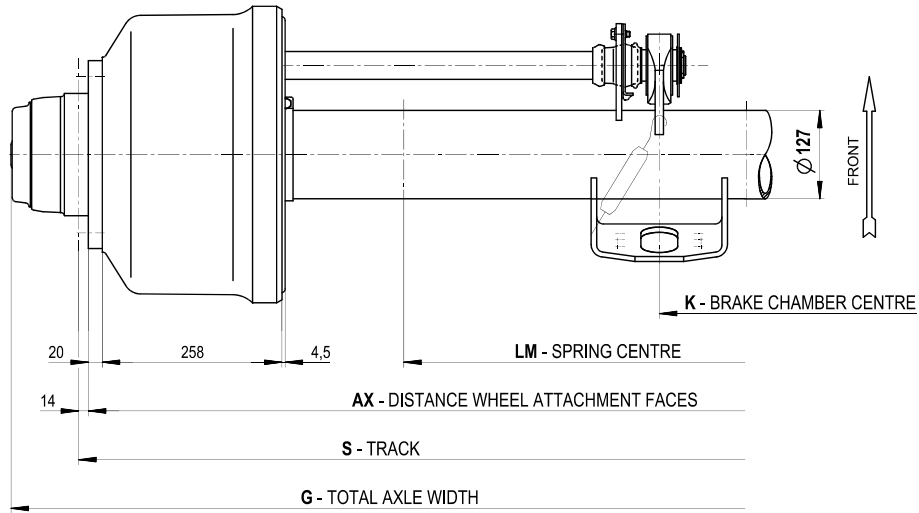

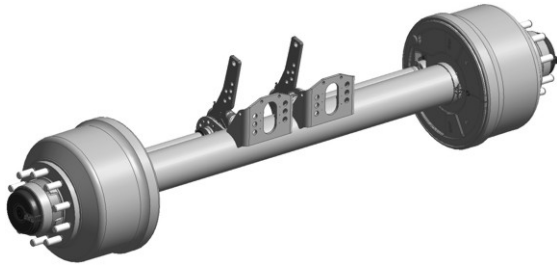
axle version / axle type / brake / test report	AX / LM	S <sup>1)</sup> / LM	G	K	weight approx. <sup>2)</sup>
	[mm]	[mm]	[mm]	[mm]	[kg] <sup>1)</sup>
 <b>Z11-3720 / SNK3720-13Z / SNK367x200 / TDB0460</b>	tyre (example): 265/70R19,5"				
	1806/900 <sup>3)</sup>	1834/900 <sup>3)</sup>	2028	250	320
	1806/980 <sup>5)</sup>	1834/980 <sup>5)</sup>	2028	250	320
	1860/900	1888/900	2082	246	323
	1860/980 <sup>4)</sup>	1888/980 <sup>4)</sup>	2082	246	323
	1926/1050 <sup>4)</sup>	1954/1050 <sup>4)</sup>	2148	312	328
	1926/1100 <sup>5)</sup>	1954/1100 <sup>5)</sup>	2148	312	328

1) **S** = **AX** + 2 \* wheel disc thickness (standard 14 mm)

2) without spring seats, slack adjuster and wheel nuts (spring seats are enclosed in the air suspension). Weight deviations lie within the permitted DIN Tolerances for the respective manufacturing process.

3) with tyres **265/70R19,5"** and air bag diameter  $\varnothing$  **350 mm** starting at **V = 30 mm**

4) with tyres **265/70R19,5"** and air bag diameter  $\varnothing$  **350 mm** starting at **V = 55 mm**

5) with tyres **265/70R19,5"** and air bag diameter  $\varnothing$  **350 mm** only with **V = 70 mm**

Note:

When choosing the suspension assembly, the clearance between air bag (max. diameter) and chosen tyre must be checked, this should be at least **25 mm**.

Further variants on request.

**Axle version SK RZ 12037**

Axle load: **12.000 kg**

Axle beam **Ø 127 mm**

Wheel fixing: **10 / 175 / 225 / 22x1,5 mm**

Suitable for: Air suspension series **U, M** with double leaf trailing arm (**S**)

Air bags with air bag diameter **Ø 350 mm**

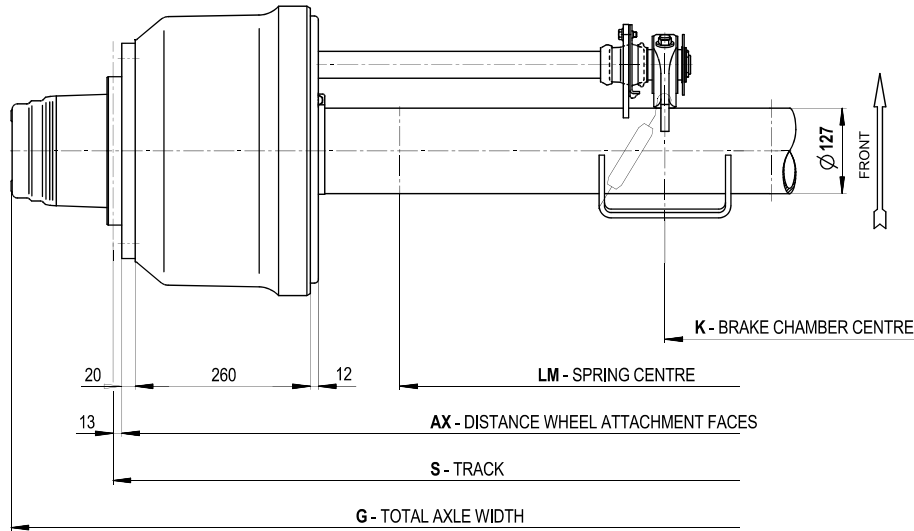

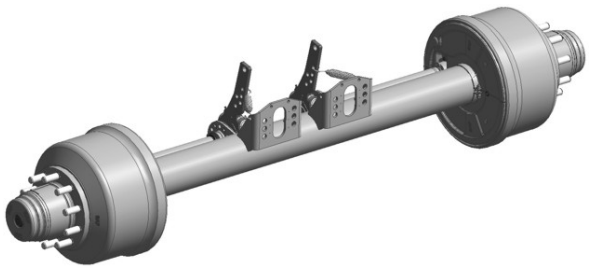
axle version / axle type / brake / test report	AX / LM	S <sup>1)</sup> / LM	G	K	weight approx. <sup>2)</sup>
	[mm]	[mm]			
 <b>SK RZ 12037 / SNK3720-13Z / SNK367x200 / TDB0460</b>	tyre (example): 285/70R19,5"				
	1820/900 <sup>4)</sup>	1846/900 <sup>3)</sup>	2149	237	335
	1860/900 <sup>3)</sup>	1886/900 <sup>3)</sup>	2189	248	338
	1860/980 <sup>4)</sup>	1886/980 <sup>4)</sup>	2189	248	338
	1926/1050 <sup>4)</sup>	1952/1050 <sup>4)</sup>	2255	312	343

1) **S** = **AX** + 2 \* wheel disc thickness (standard 13 mm)

2) without spring seats, slack adjuster and wheel nuts (spring seats are enclosed in the air suspension).  
Weight deviations lie within the permitted DIN Tolerances for the respective manufacturing process.

3) with tyres **285/70R19,5"** and air bag diameter **Ø 350 mm** starting at **V = 30 mm**

4) with tyres **285/70R19,5"** and air bag diameter **Ø 350 mm** starting at **V = 55 mm**

Note:

When choosing the suspension assembly, the clearance between air bag (max. diameter) and chosen tyre must be checked, this should be at least **25 mm**.

Further variants on request.



**Axle version S9-4218**

Axle load maximum: **9.000 kg**

Axle beam **Ø 146 mm**

Wheel fixing: **10 / 280 / 335 / 22x1,5 mm**

Suitable for: Air suspension series **U, M, EO** with single leaf trailing arm (**EN**) and

Air suspension series **U, M** with double leaf trailing arm (**S**)

Air bags with air bag diameter **Ø 300 mm** and **Ø 350 mm**

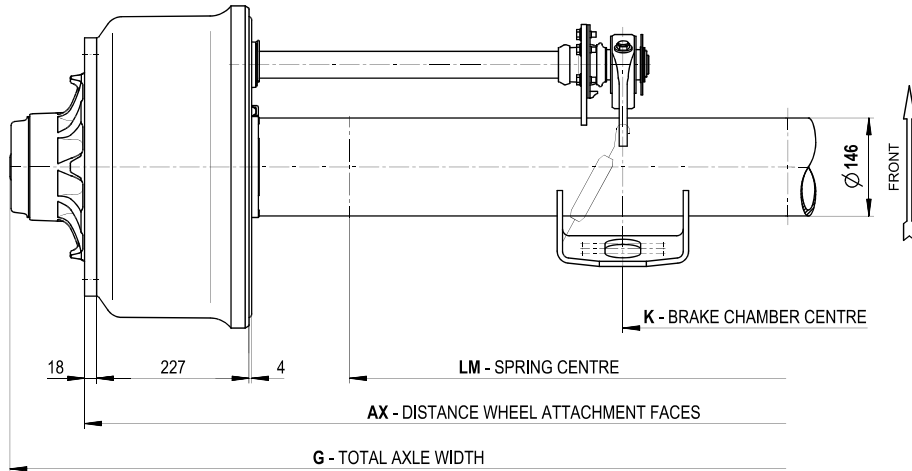

axle version / axle type / brake / test report	AX <sup>1)</sup> / LM [mm]	G [mm]	K [mm]	weight approx. <sup>2)</sup> [kg]
 <p><b>S9-4218</b> / SNK4218-11S / SNK420x180 / TDB0381</p>	tyre (example): 385/65R22,5"			
	1970/1100	2192	366	291
	1970/1200 <sup>3)</sup>	2192	366	291
	2040/1200	2262	436	293
	2040/1300 <sup>4)</sup>	2262	436	293
	2090/1300 <sup>3)</sup>	2312	486	295
	2140/1300	2362	536	297
2140/1400 <sup>4)</sup>	2362	536	297	

1) **AX = S**

2) without spring seats, slack adjuster and wheel nuts (spring seats are enclosed in the air suspension).  
Weight deviations lie within the permitted DIN Tolerances for the respective manufacturing process.

3) with tyres **385/65R22,5"** and air bag diameter **Ø 350 mm** starting at **V = 30 mm**

4) with tyres **385/65R22,5"** and air bag diameter **Ø 350 mm** only with **V = 55 mm**

Note:

When choosing the suspension assembly, the clearance between air bag (max. diameter) and chosen tyre must be checked, this should be at least **25 mm**.

Further variants on request.

**Axle version Z9-4218**

Axle load maximum: **9.000 kg**

Axle beam **Ø 146 mm**

Wheel fixing: **10 / 280 / 335 / 22x1,5 mm**

Suitable for: Air suspension series **U, M, EO** with single leaf trailing arm (**EN**) and

Air suspension series **U, M** with double leaf trailing arm (**S**)

Air bags with air bag diameter **Ø 300 mm** and **Ø 350 mm**

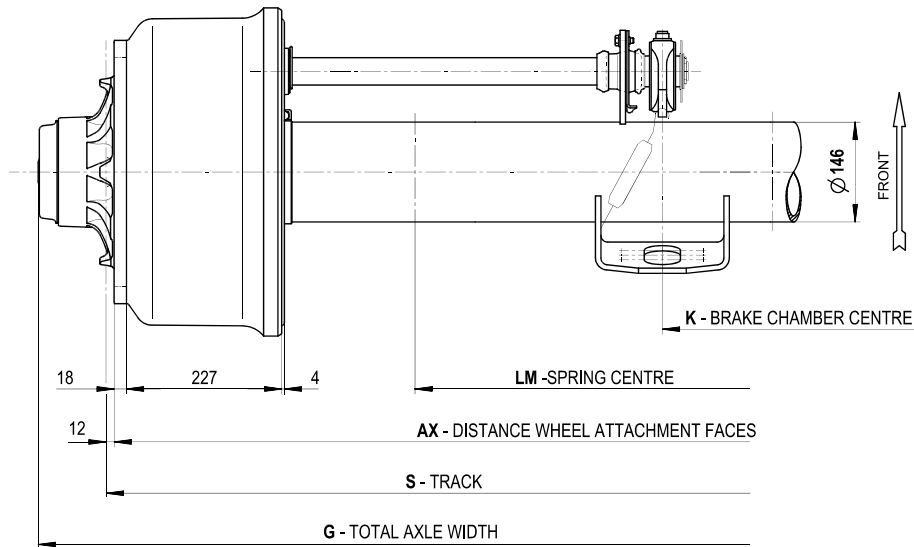

axle version / axle type / brake / test report	AX / LM	S <sup>1)</sup> / LM	G	K	weight approx. <sup>2)</sup>
	[mm]	[mm]	[mm]	[mm]	[kg]
 <b>Z9-4218 / SNK4218-11Z / SNK420x180 / TDB0483</b>	tyre (example): 255/70R22,5"				
	1820/900 <sup>3)</sup>	1844/900 <sup>3)</sup>	2042	221	310
	1820/980 <sup>4)</sup>	1844/980 <sup>4)</sup>	2042	221	310
	1860/980 <sup>3)</sup>	1884/980 <sup>3)</sup>	2082	219	312

1) **S = AX + 2 \* wheel disc thickness (standard 12 mm)**

2) without spring seats, slack adjuster and wheel nuts (spring seats are enclosed in the air suspension).  
Weight deviations lie within the permitted DIN Tolerances for the respective manufacturing process.

3) with tyres **255/70R22,5** and air bag diameter **Ø 350 mm** starting at **V = 30 mm**

4) with tyres **255/70R22,5"** and air bag diameter **Ø 350 mm** starting at **V = 55 mm**

Note:

When choosing the suspension assembly, the clearance between air bag (max. diameter) and chosen tyre must be checked, this should be at least **25 mm**.

Further variants on request.

**Axle version S11-4220**

Axle load maximum: **11.000 kg**

Axle beam **Ø 146 mm**

Wheel fixing: **10 / 280 / 335 / 22x1,5 mm**

Suitable for: Air suspension series **U, M, EO** with single leaf trailing arm (**EN**) and

Air suspension series **U, M** with double leaf trailing arm (**S**)

Air bags with air bag diameter **Ø 350 mm**

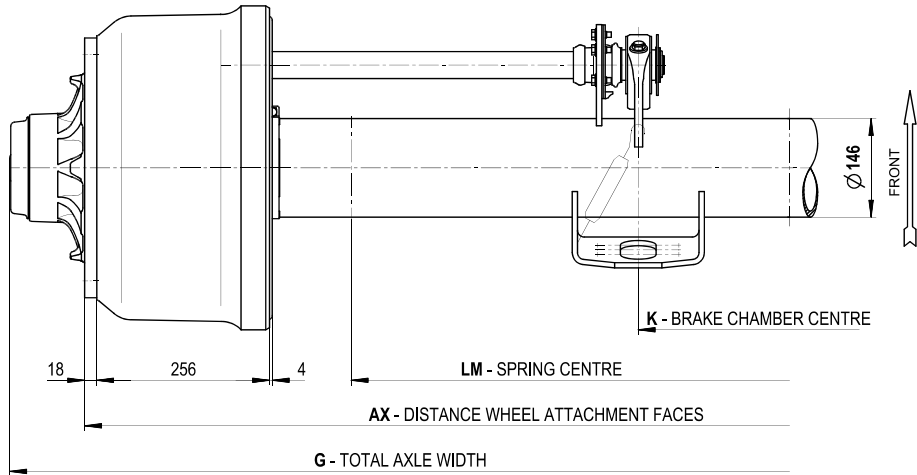

axle version / axle type / brake / test report	AX <sup>1)</sup> / LM [mm]	G [mm]	K [mm]	weight approx. <sup>2)</sup> [kg]
 <b>S11-4220 / SNK4220-13S / SNK420x200 / TDB0455</b>	tyre (example): 425/65R22,5"			
	1970/1100	2192	329	317
	1970/1200 <sup>4)</sup>	2192	329	317
	2040/1200 <sup>3)</sup>	2262	399	320
	2040/1300 <sup>4)</sup>	2262	399	320
	2090/1300 <sup>3)</sup>	2312	449	322

1) **AX = S**

2) without spring seats, slack adjuster and wheel nuts (spring seats are enclosed in the air suspension).  
Weight deviations lie within the permitted DIN Tolerances for the respective manufacturing process.

3) with tyres **425/65R22,5"** and air bag diameter **Ø 350 mm** starting at **V = 30 mm**

4) with tyres **425/65R22,5"** and air bag diameter **Ø 350 mm** starting at **V = 55 mm**

Note:

When choosing the suspension assembly, the clearance between air bag (max. diameter) and chosen tyre must be checked, this should be at least **25 mm**.

Further variants on request.

**Axle version Z11-4220**

Axle load maximum: **11.000 kg**

Axle beam **Ø 146 mm**

Wheel fixing: **10 / 280 / 335 / 22x1,5 mm**

Suitable for: Air suspension series **U, M** with double leaf trailing arm (**S**)

Air bags with air bag diameter **Ø 350 mm**

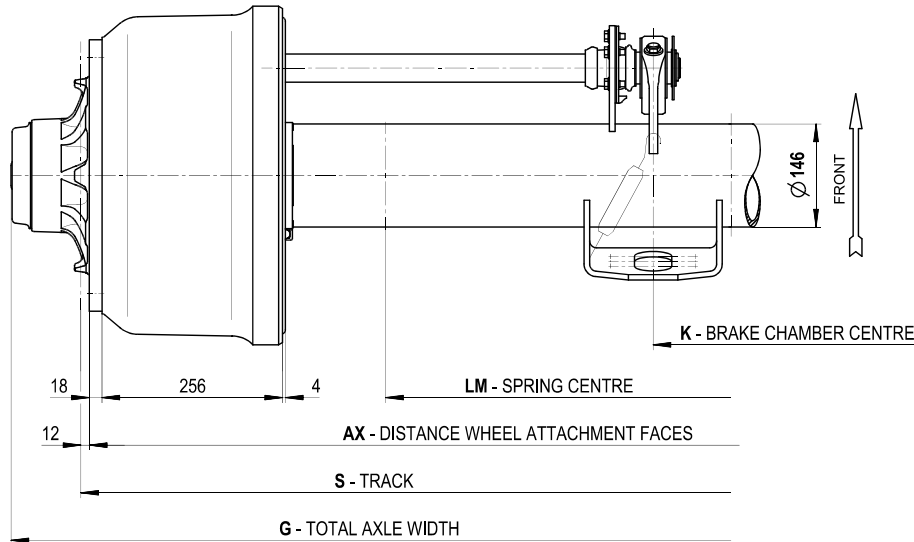

axle version / axle type / brake / test report	AX / LM	S <sup>1)</sup> / LM	G	K	weight approx. <sup>2)</sup>
	[mm]	[mm]	[mm]	[mm]	[kg]
 <b>Z11-4220 / SNK4220-13Z / SNK420x200 / TDB0456</b>	1820/900 <sup>3)</sup>	1844/900 <sup>3)</sup>	2042	221	312
	1820/980 <sup>5)</sup>	1844/980 <sup>5)</sup>	2042	221	312
	1860/980 <sup>4)</sup>	1884/980 <sup>4)</sup>	2082	219	314

- 1) **S = AX + 2 \* wheel disc thickness (standard 12 mm)**
- 2) without spring seats, slack adjuster and wheel nuts (spring seats are enclosed in the air suspension).  
Weight deviations lie within the permitted DIN Tolerances for the respective manufacturing process.
- 3) with tyres **275/70R22,5"** and air bag diameter **Ø 350 mm** starting at **V = 30 mm**
- 4) with tyres **275/70R22,5"** and air bag diameter **Ø 350 mm** starting at **V = 55 mm**
- 5) with tyres **275/70R22,5"** and air bag diameter **Ø 350 mm** only with **V = 70 mm**

Note:

When choosing the suspension assembly, the clearance between air bag (max. diameter) and chosen tyre must be checked, this should be at least **25 mm**.

Further variants on request.

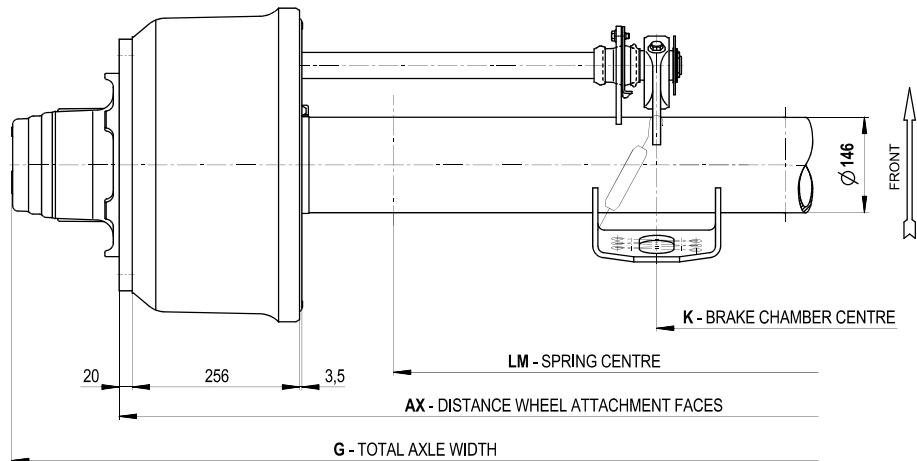
**Axle version SK RS 12242**Axle load maximum: **12.000 kg**Axle beam **Ø 146 mm**Wheel fixing: **10 / 280 / 335 / 22x1,5 mm**Suitable for: Air suspension series **U, M** with double leaf trailing arm (**S**)Air bags with air bag diameter **Ø 350 mm**

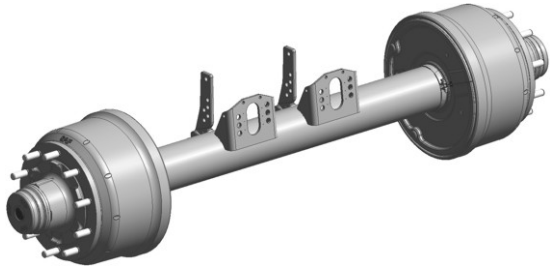
axle version / axle type / brake / test report	AX <sup>1)</sup> / LM [mm]  tyre (example): 445/65R22,5"	G [mm]	K [mm]	weight approx. <sup>2)</sup> [kg]
	1970/1100 <sup>3)</sup>	2299	325	347
	1970/1200 <sup>4)</sup>	2299	325	347
	2040/1200 <sup>3)</sup>	2369	395	350
	<b>SK RS 12242 / SNK4220-13S / SNK420x200 / TDB0455</b>	2040/1300 <sup>5)</sup>	2369	395

1) **AX = S**2) without spring seats, slack adjuster and wheel nuts (spring seats are enclosed in the air suspension).  
Weight deviations lie within the permitted DIN Tolerances for the respective manufacturing process.3) with tyres **445/65R22,5"** and air bag diameter **Ø 350 mm** starting at **V = 30 mm**4) with tyres **445/65R22,5"** and air bag diameter **Ø 350 mm** starting at **V = 55 mm**5) with tyres **445/65R22,5"** and air bag diameter **Ø 350 mm** only with **V = 70 mm**

Note:

When choosing the suspension assembly, the clearance between air bag (max. diameter) and chosen tyre must be checked, this should be at least **25 mm**.

Further variants on request.

**Axle version SK RZ 12242**

Axle load maximum: **12.000 kg**

Axle beam **Ø 146 mm**

Wheel fixing: **10 / 280 / 335 / 22x1,5 mm**

Suitable for: Air suspension series **U, M** with double leaf trailing arm (**S**)

Air bags with air bag diameter **Ø 350 mm**

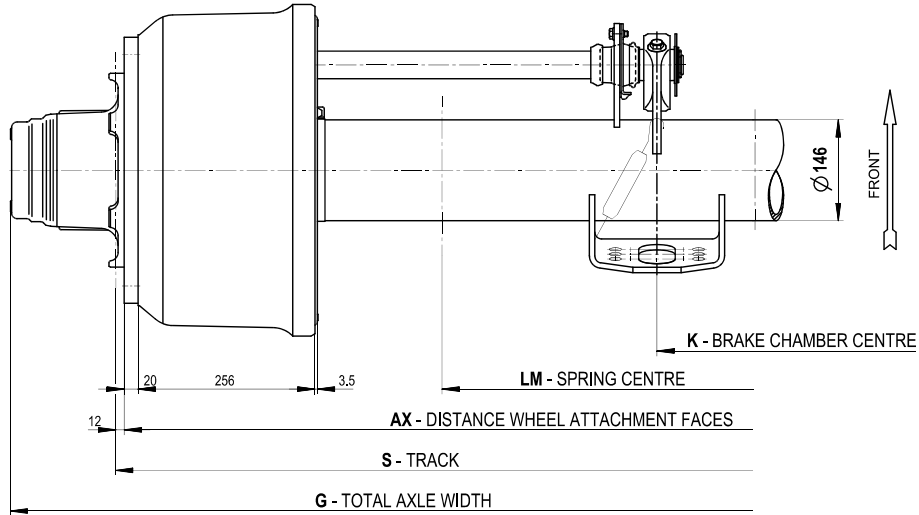

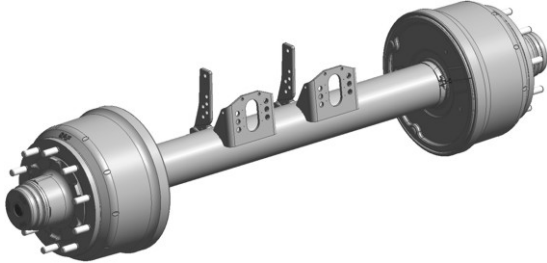
axle version / axle type / brake / test report	AX / LM [mm]	S <sup>1)</sup> / LM [mm]	G [mm]	K [mm]	weight approx. <sup>2)</sup> [kg]
 <b>SK RZ 12242 / SNK4220-13Z / SNK420x200 / TDB0456</b>	tyre (example): 295/80R22,5"				
	1820/900 <sup>4)</sup>	1844/900 <sup>4)</sup>	2149	220	332
	1860/900 <sup>3)</sup>	1884/980 <sup>3)</sup>	2189	231	334
	1860/980 <sup>5)</sup>	1884/980 <sup>5)</sup>	2189	231	334

- 1) **S = AX + 2 \* wheel disc thickness (standard 12 mm)**
- 2) without spring seats, slack adjuster and wheel nuts (spring seats are enclosed in the air suspension).  
Weight deviations lie within the permitted DIN Tolerances for the respective manufacturing process.
- 3) with tyres **295/80R22,5"** and air bag diameter **Ø 350 mm** starting at **V = 30 mm**
- 4) with tyres **295/80R22,5"** and air bag diameter **Ø 350 mm** starting at **V = 55 mm**
- 5) with tyres **295/80R22,5"** and air bag diameter **Ø 350 mm** only with **V = 70 mm**

Note:  
When choosing the suspension assembly, the clearance between air bag (max. diameter) and chosen tyre must be checked, this should be at least **25 mm**.

Further variants on request.

**Axle version ZL11-3020**

Axle load maximum: **10.000 kg**

Axle beam  $\varnothing$  **133 mm**

Wheel fixing: **10 / 175 / 225 / 22x1,5 mm**

Suitable for: Air suspension series **U, M** with double leaf trailing arm (**S**)

Air bags with air bag diameter  $\varnothing$  **350 mm**

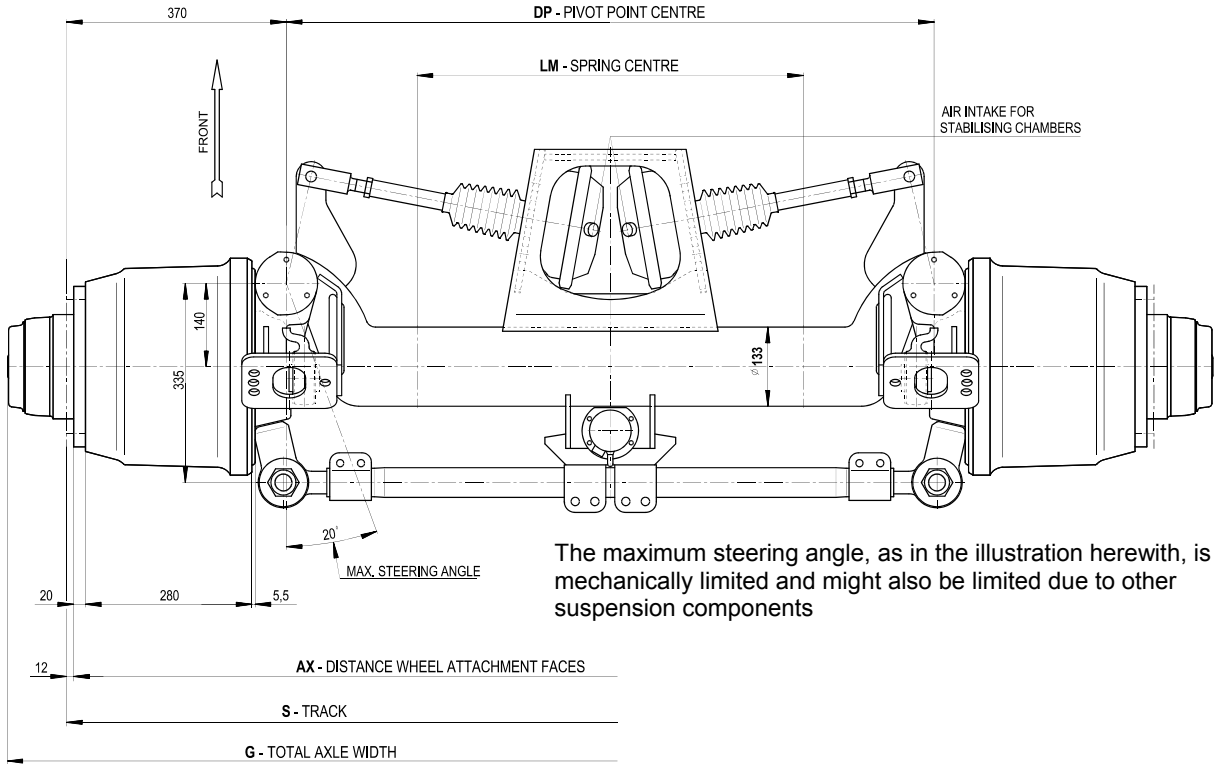

The maximum steering angle, as in the illustration herewith, is mechanically limited and might also be limited due to other suspension components

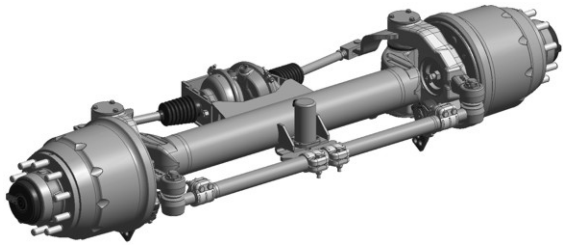
axle version / axle type / brake / test report	AX <sup>1)</sup> / LM	S / LM	G	DP	weight approx. <sup>2)</sup>
	[mm]	[mm]	[mm]	[mm]	[kg]
 <b>ZL11-3020 / SNK3020-13Z / SNK300x200 / TDB0487</b>	tyre (example): 235/75R17,5"				
	1806/660	1830/660	2028	1090	505
	1860/700	1884/700	2082	1144	507,5
	1926/750	1950/750	2148	1210	511
	1971/800	1995/800	2193	1255	514

1) **S** = **AX** + 2 \* wheel disc thickness (standard 12 mm)

2) without spring seats, slack adjuster and wheel nuts (spring seats are enclosed in the air suspension).  
Weight deviations lie within the permitted DIN Tolerances for the respective manufacturing process.

**Note:**

When choosing the suspension assembly, the clearance between air bag (max. diameter) and chosen tyre must be checked, this should be at least **25 mm**.

**All variants on request**

**Axle version SL9-4218**

Axle load maximum: **9.000 kg**

Axle beam **Ø 146 mm**

Wheel fixing: **10 / 280 / 335 / 22x1,5 mm**

Suitable for: Air suspension series **U, M, EO** with single leaf trailing arm (**EN**) and

Air suspension series **U, M** with double leaf trailing arm (**S**)

Air bags with air bag diameter **Ø 300 mm** and **Ø 350 mm**

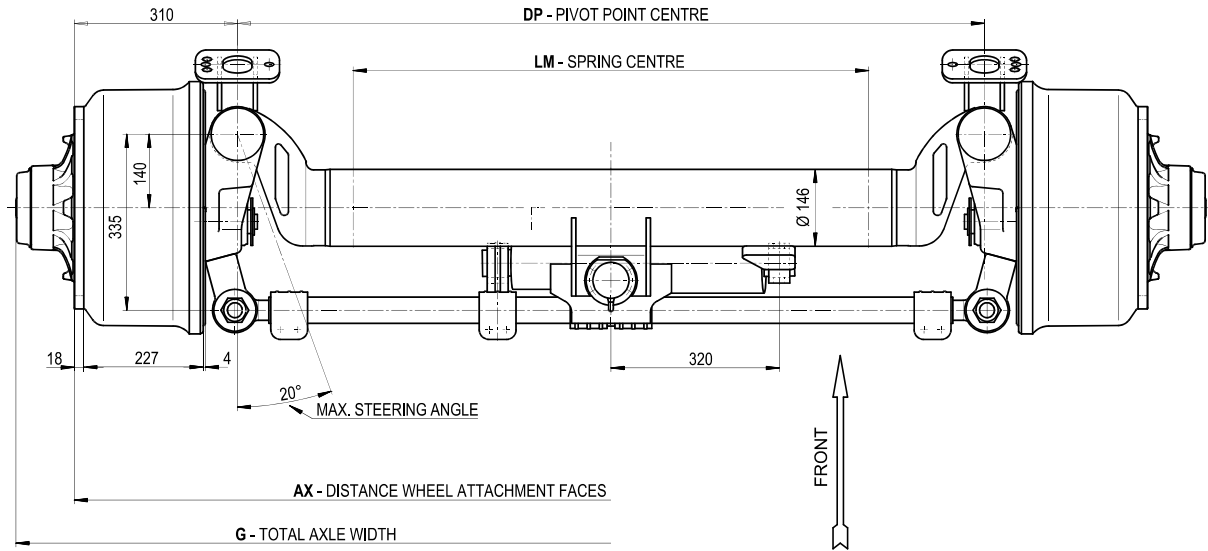

The maximum steering angle, as in the illustration herewith, is mechanically limited and might also be limited due to other suspension components.

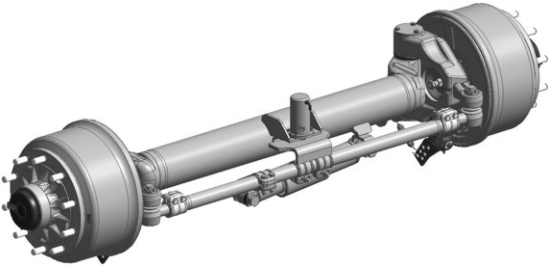
axle version / axle type / brake / test report	AX <sup>1)</sup> / LM [mm] tyre (example): 385/65R22,5"	G [mm]	DP [mm]	weight approx. <sup>2)</sup> [kg]
 <p><b>SL9-4218 / SNK4218-11S / SNK420x180 / TDB0381</b></p>	2040/980	2262	1420	453
	2090/980	2312	1470	455
	2090/1030	2312	1470	455
	2140/1080	2362	1520	457

1) **AX = S**

2) without spring seats, slack adjuster and wheel nuts (spring seats are enclosed in the air suspension).  
Weight deviations lie within the permitted DIN Tolerances for the respective manufacturing process.

Note:

When choosing the suspension assembly, the clearance between air bag (max. diameter) and chosen tyre must be checked, this should be at least **25 mm**.

Further variants on request.



**Axle version SK ZRLZ 12030**

Axle load maximum: **12.000 kg**

Axle beam **Ø 133 mm**

Wheel fixing: **10 / 175 / 225 / 22x1,5 mm**

Suitable for: Air suspension series **U, M** with double leaf trailing arm (**S**)

Air bags with air bag diameter **Ø 350 mm**

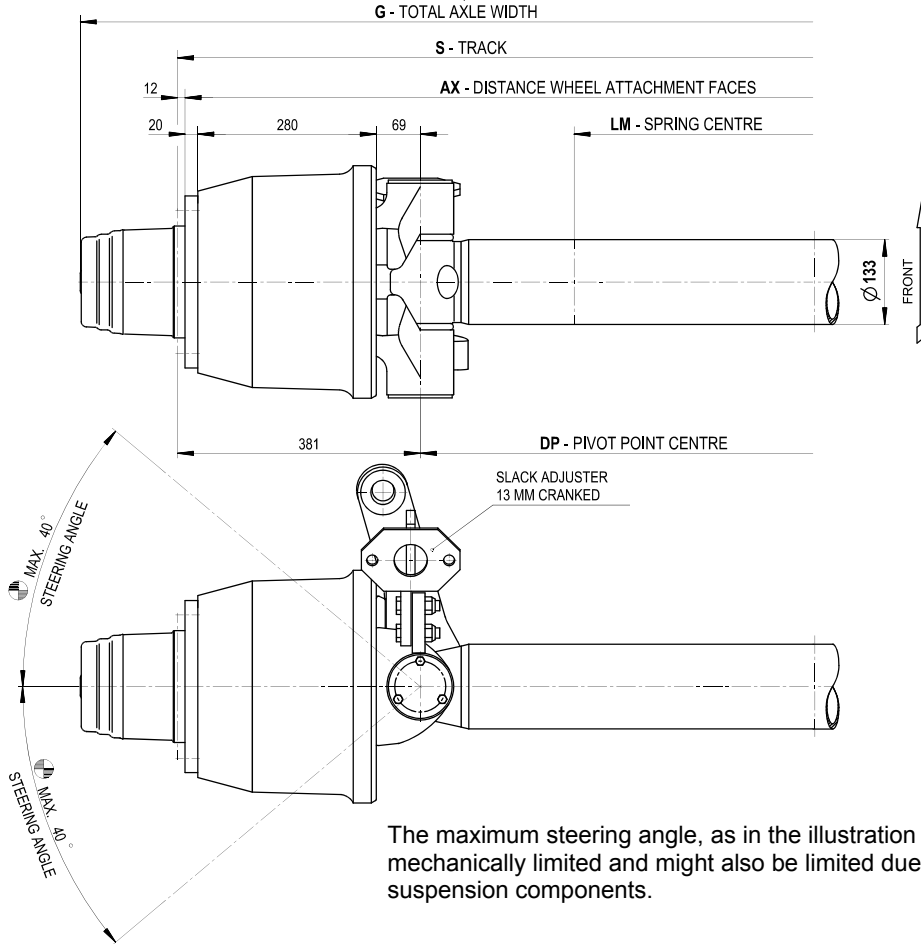

The maximum steering angle, as in the illustration herewith, is mechanically limited and might also be limited due to other suspension components.

axle version / axle type / brake / test report	AX <sup>1)</sup> / LM [mm]	S / LM [mm]	G [mm]	DP [mm]	weight approx. <sup>2)</sup> [kg]
	tyre (example): 235/75R17,5"				
	1860/700	1884/700	2082	1122	469,5
	1926/750	1950/750	2148	1188	471
<b>SK ZRLZ 12030 / SNK3020-13Z / SNK300x200 / TDB0487</b>	1971/800	1995/800	2193	1233	474

1) **S = AX + 2 \* wheel disc thickness (standard 12 mm)**

2) without spring seats, slack adjuster and wheel nuts (spring seats are enclosed in the air suspension).  
Weight deviations lie within the permitted DIN Tolerances for the respective manufacturing process.

**Note:**

When choosing the suspension assembly, the clearance between air bag (max. diameter) and chosen tyre must be checked, this should be at least **25 mm**.



**All variants on request**

**Geometry hanger bracket „steel“ – bolted version**

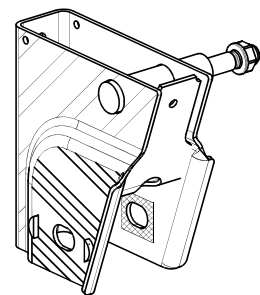
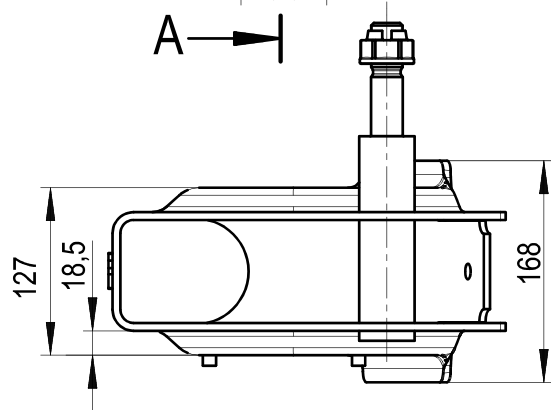
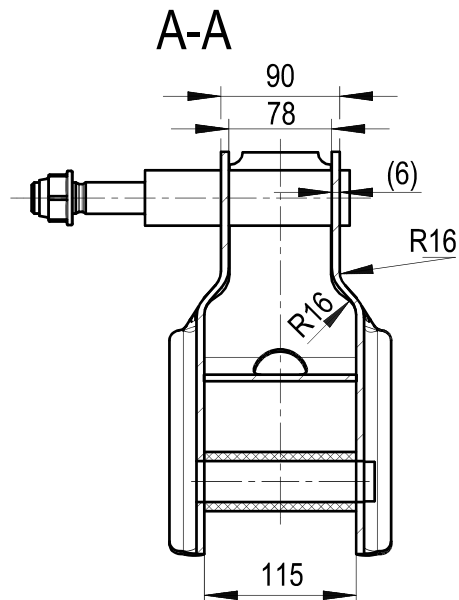
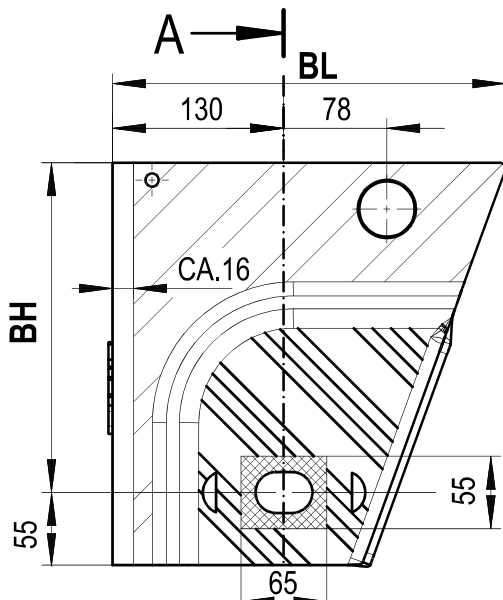

illustration 2 183 0747 01, „inside“ – „outside“

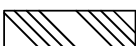

-  MEASURING RANGE 1 = 90 +2
-  MEASURING RANGE 2 = 127 ±2
-  MEASURING RANGE 3 = 115 +2

Dimension [mm]		Hanger bracket number:	Version
BH	BL		
250	298	2 183 0745 01	Left
250	298	2 183 0746 01	Right
290	313	2 183 0747 01	Left
290	313	2 183 0748 01	Right
355	337	2 183 0749 01	Left
355	337	2 183 0750 01	Right

With hanger bracket non-primed, the end number changes from von 01 in 91, example: 2 183 0747 91

**Geometry hanger bracket „steel“ – screwed version**

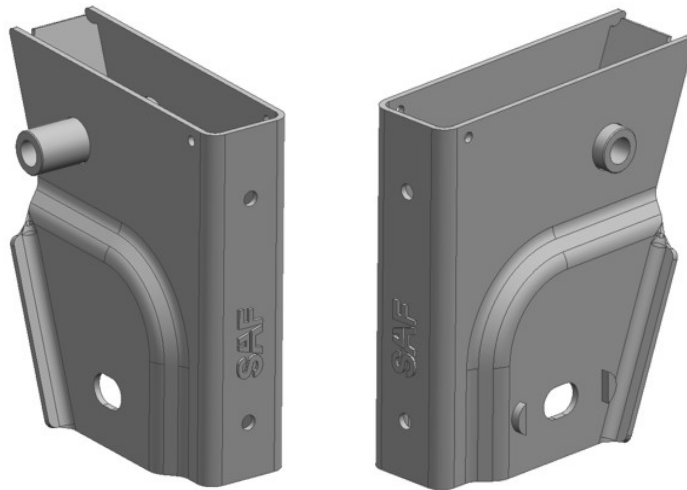
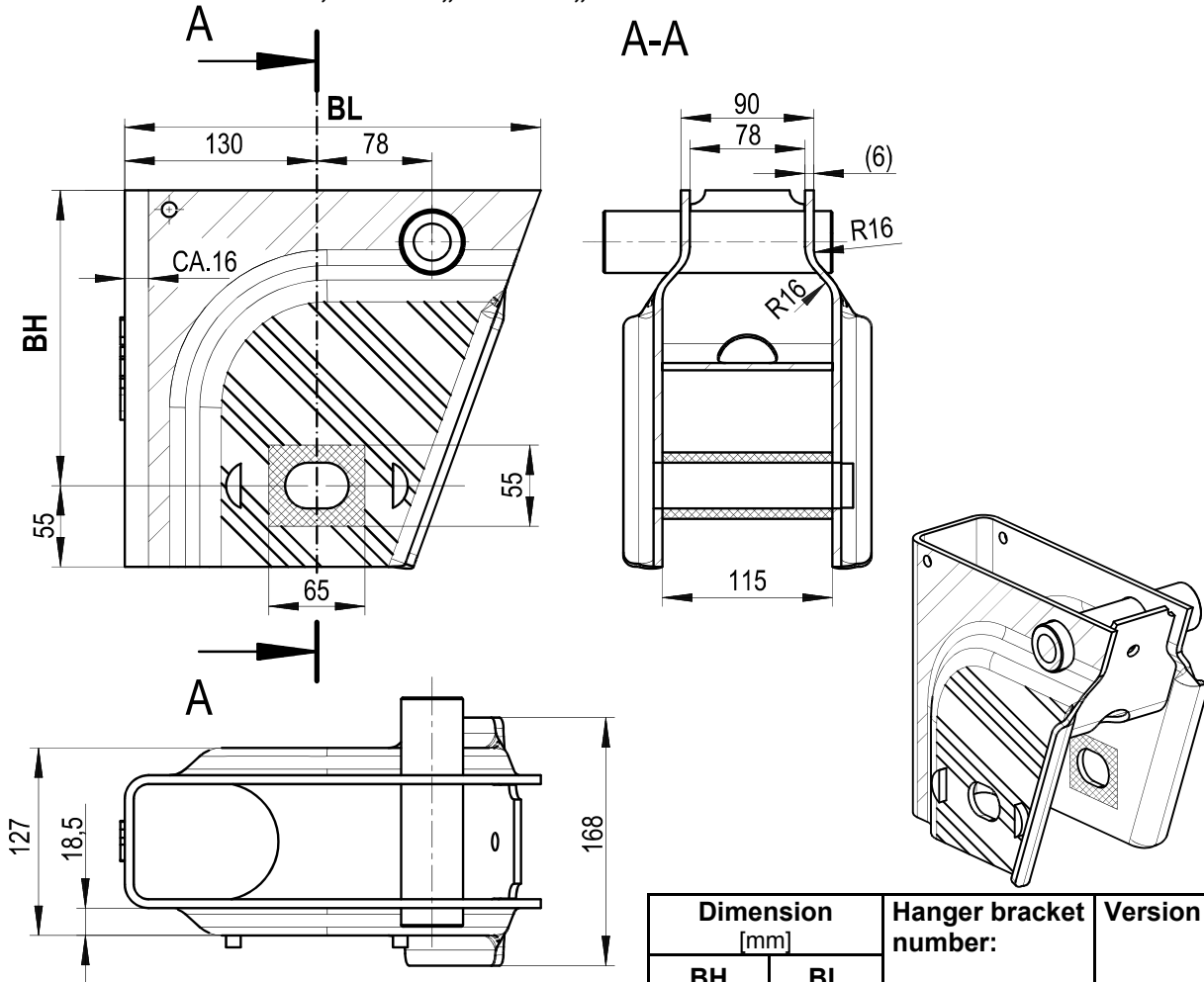





illustration 2 183 0753 01, „inside“ – „outside“



-  MEASURING RANGE 1 = 90 +2
-  MEASURING RANGE 2 = 127 ±2
-  MEASURING RANGE 3 = 115 +2

Dimension [mm]		Hanger bracket number:	Version
BH	BL		
200	282	2 183 0779 01	Left
200	282	2 183 0780 01	Right
250	298	2 183 0751 01	Left
250	298	2 183 0752 01	Right
290	313	2 183 0753 01	Left
290	313	2 183 0754 01	Right
355	337	2 183 0755 01	Left
355	337	2 183 0756 01	Right

With hanger bracket non-primed, the end number changes from von 01 in 91, example: 2 183 0753 91

**Geometry hanger bracket „steel“ - „screw-on“**

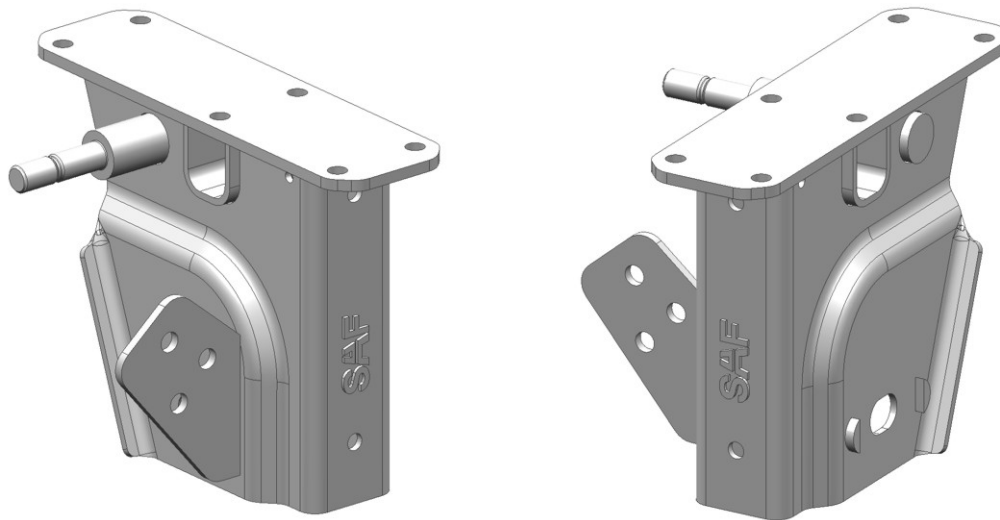

**illustration 2 183 0879 00, „inside“ – „outside“**

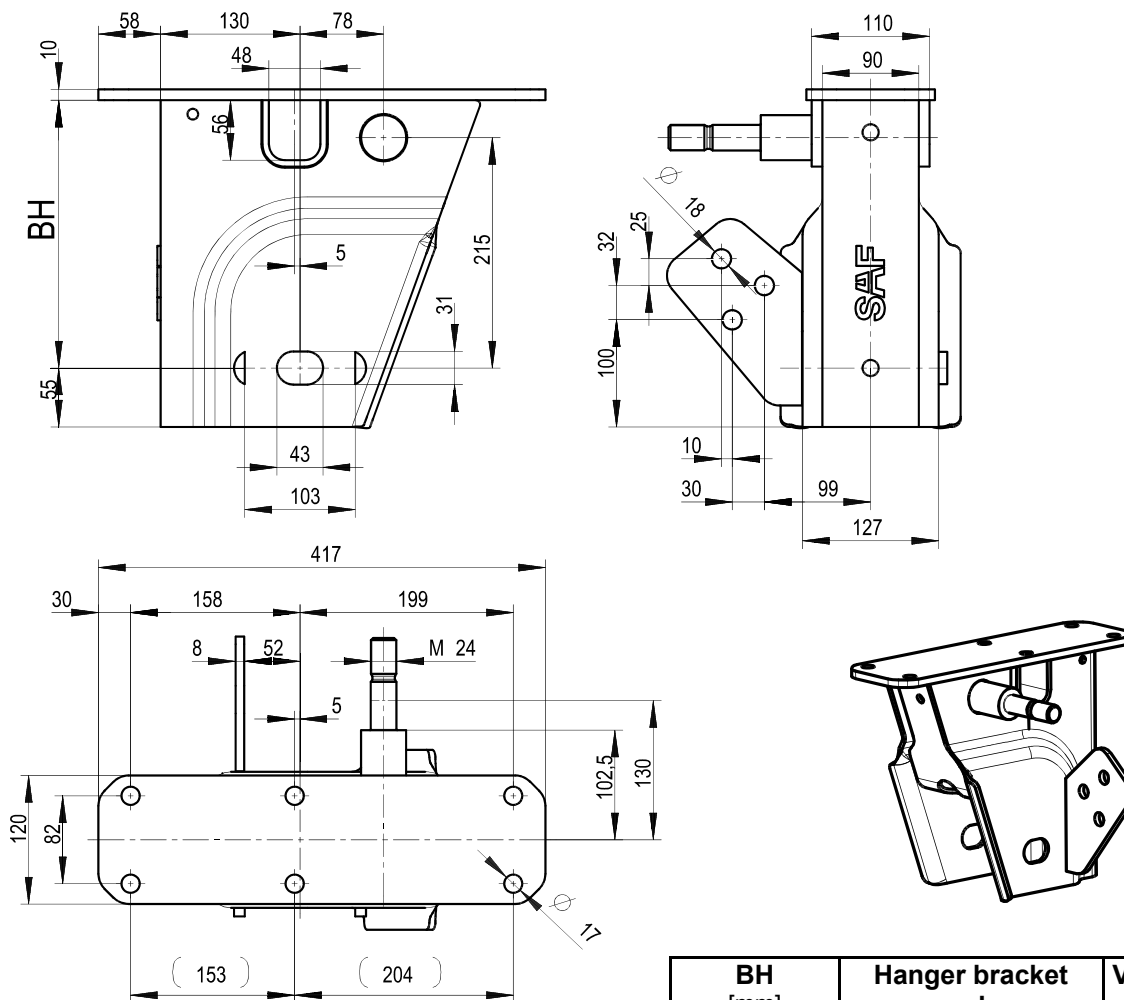

For maximum axle load **10 Ton** with single tyre.

Installation see [Page 89](#)

BH [mm]	Hanger bracket number	Version
250	2 183 0879 00	Left
250	2 183 0880 00	Right
290	2 183 0881 00	Left
290	2 183 0882 00	Right

With hanger bracket non-primed, the end number changes from 00 in 90, example: 2 183 0879 90

### Geometry cross member, rigid axle

LM = HM

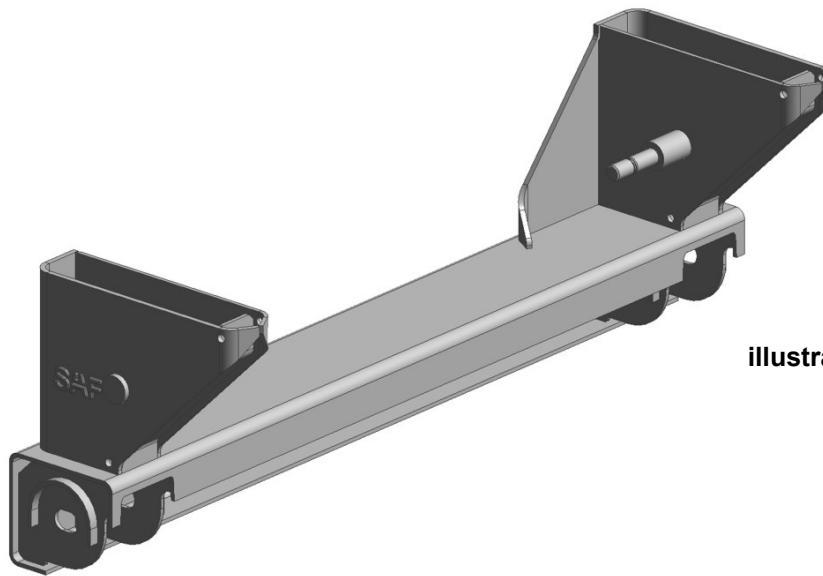
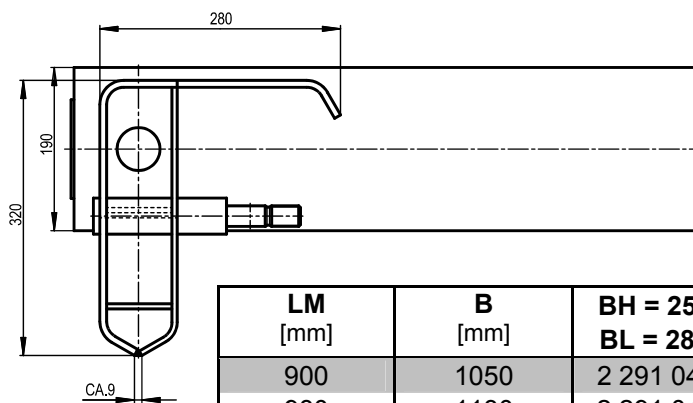
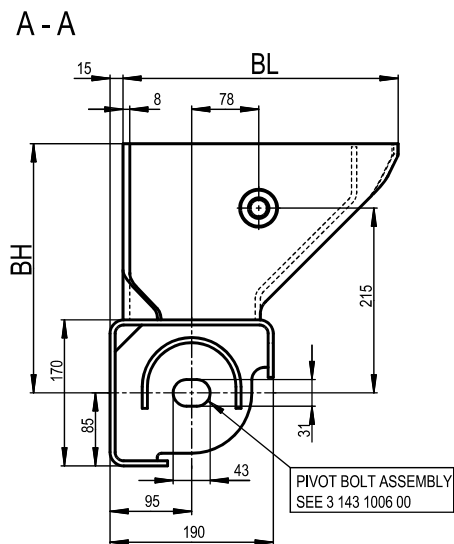
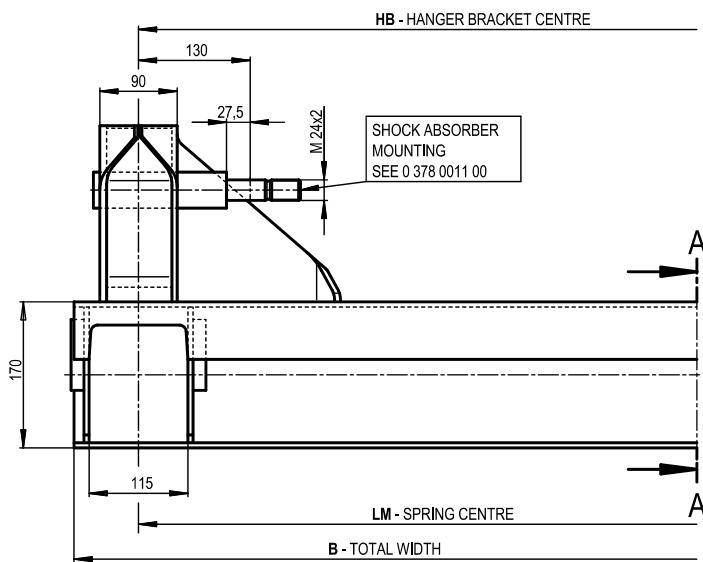

illustration 2 291 0497 01



LM [mm]	B [mm]	BH = 250 mm BL = 280 mm	BH = 290 mm BL = 320 mm	BH = 355 mm BL = 385 mm
900	1050	2 291 0492 01	2 291 0488 01	2 291 0491 01
980	1130	2 291 0482 01	2 291 0503 01	2 291 0490 01
1100	1250	2 291 0462 01	2 291 0501 01	2 291 0489 01
1200	1350	2 291 0473 01	2 291 0496 01	2 291 0497 01
1300	1450	2 291 0463 01	2 291 0349 01	2 291 0370 01

other versions on request

With non-primed cross members the end number is changing from 01 in 91, example: 2 291 0497 91.  
Not applicable when combined, air suspension serie „U“ and axles with disc brake.

### Adjustable pivot bolt for hanger bracket „steel“ and cross member

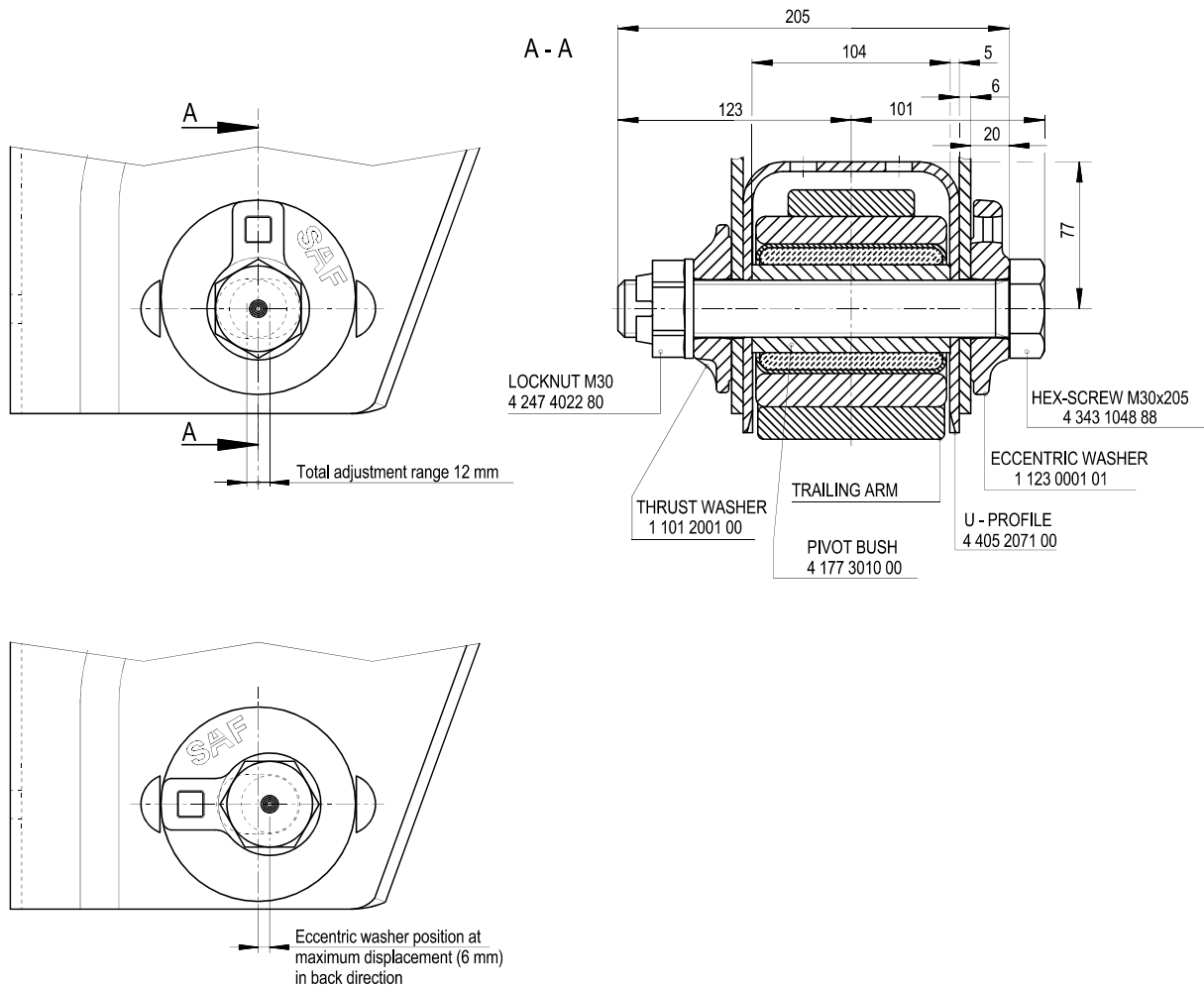

**Tightening torque: 400 Nm + 120°; tightening procedure see page 89**

Ref.nr.: 03 143 1006 00

**Shock absorber assembly: hanger bracket „steel“**

**bolted (standard)**

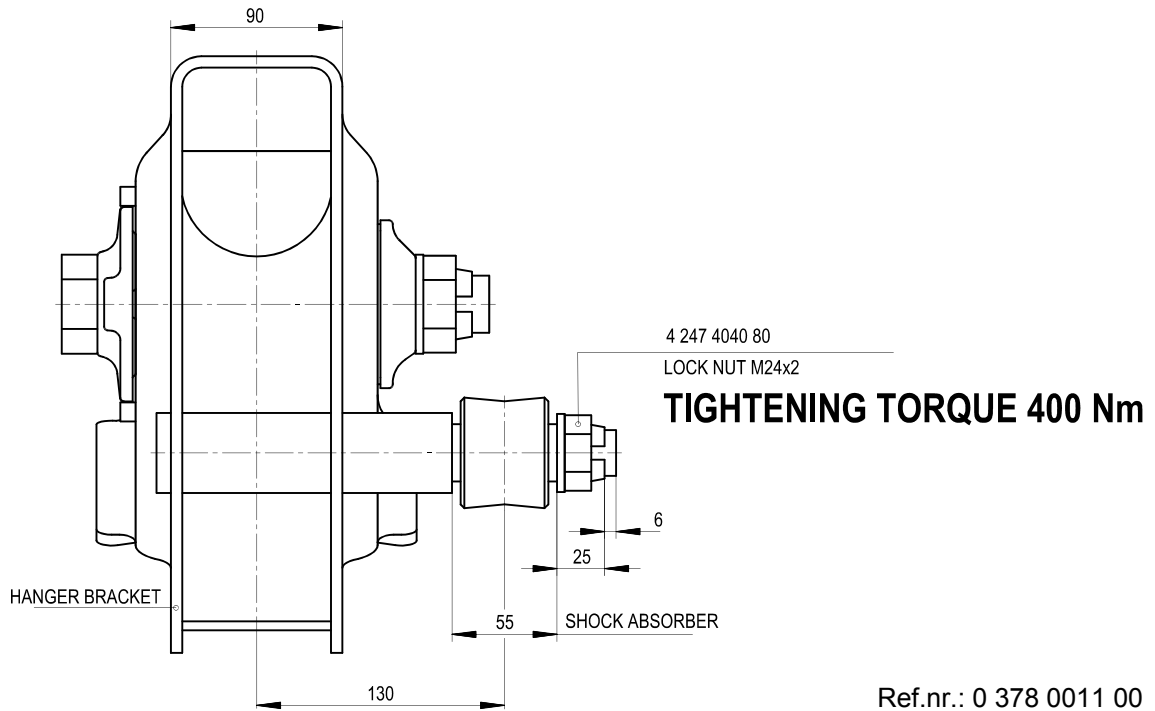

**with hex-screw**

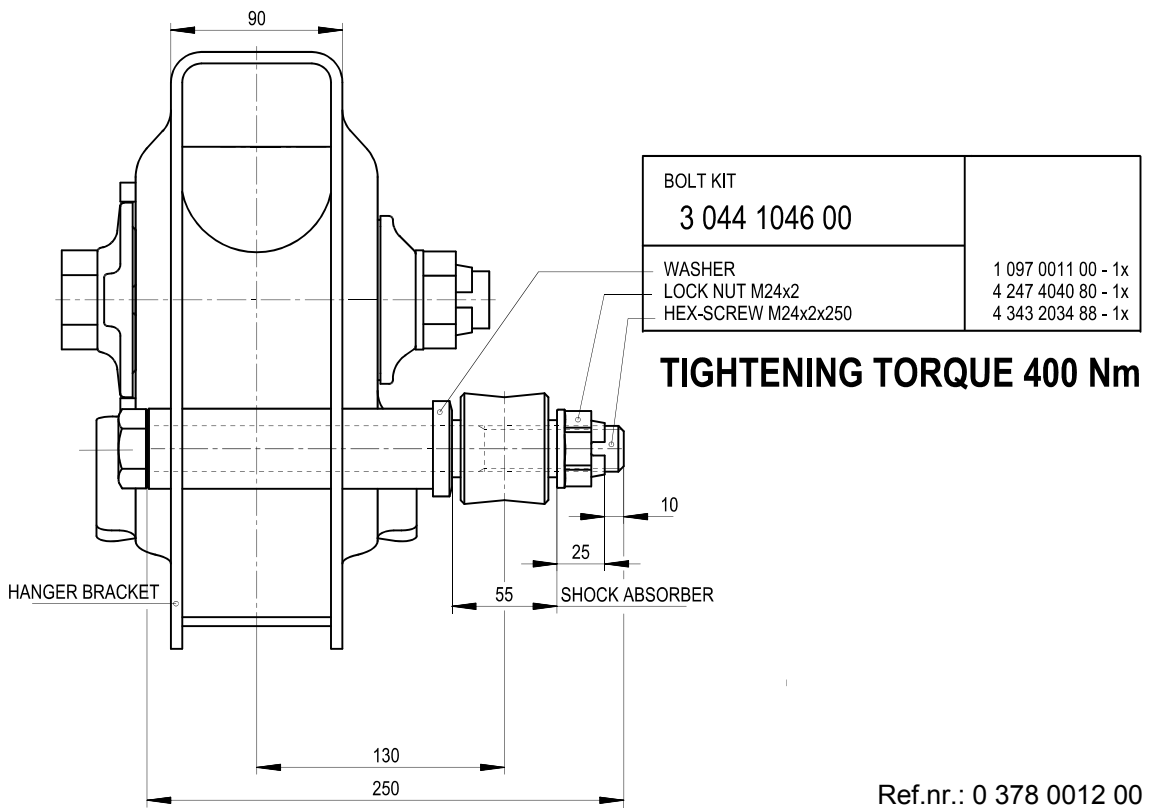

**Geometry hanger bracket „aluminium“**



illustration 2 183 0730 00

Symmetrical hanger brackets

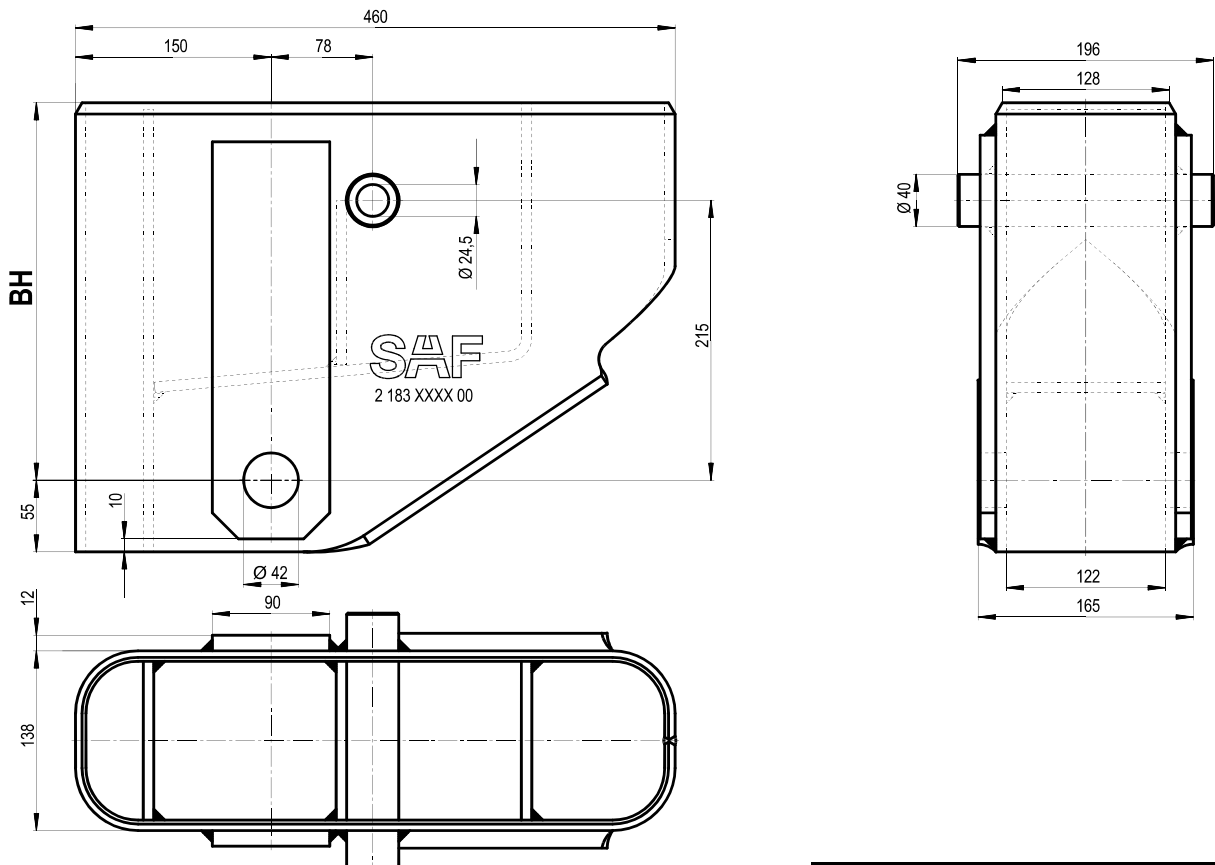

BH [mm]	Hanger bracket number
250	2 183 0679 00
290	2 183 0730 00
355	2 183 0731 00

Not applicable when combined, air suspension serie „U“ and axles with disc brake.



**Pivot bolt for hanger bracket „aluminium“**

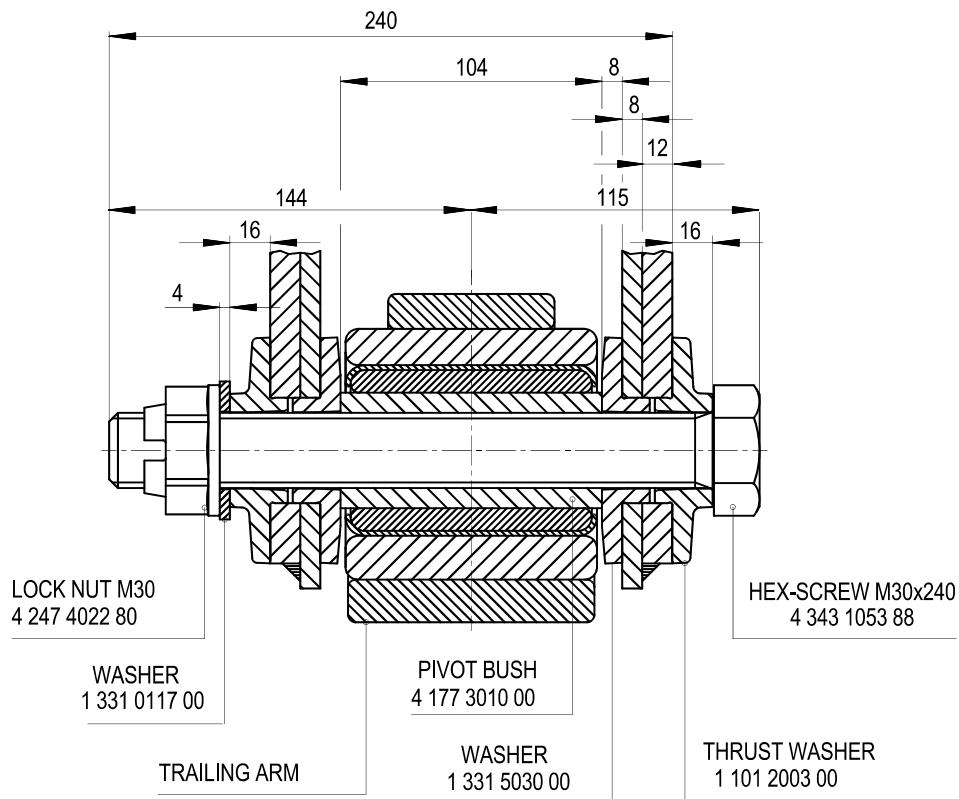

**Attention:**  
Screw connections at aluminium hanger brackets are not maintenance free!  
Service intervals see SAF-HOLLAND – Operating and service manuals.  
Inspection torque 1200 Nm!

**Tightening moment: 400 Nm + 120°; tightening procedure see page**

Ref.nr.: 03 143 1007 00

**Shock absorber assembly: hanger bracket „aluminium“**

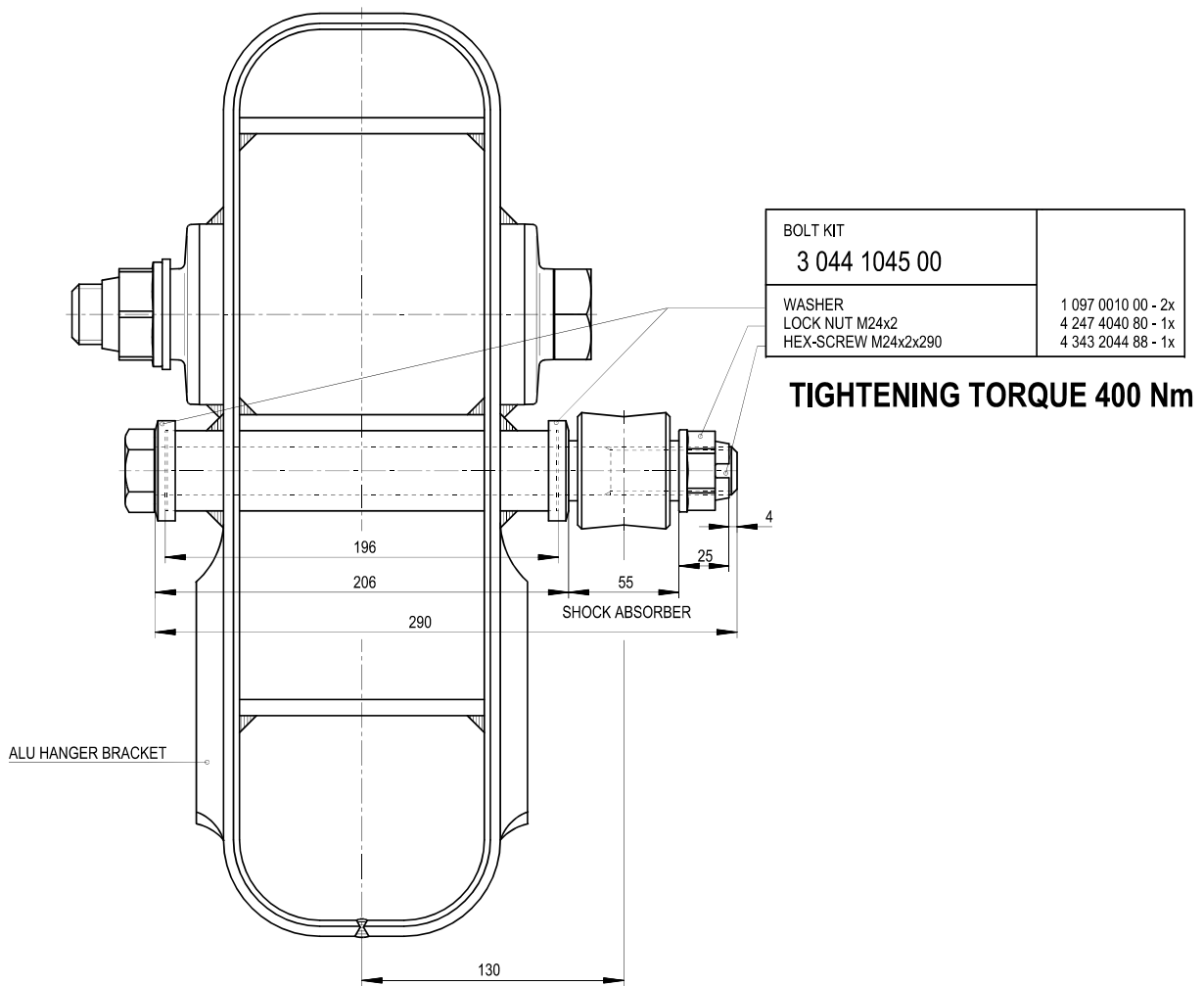

Ref.nr.: 0 378 0010 00

**Shock absorber overview**

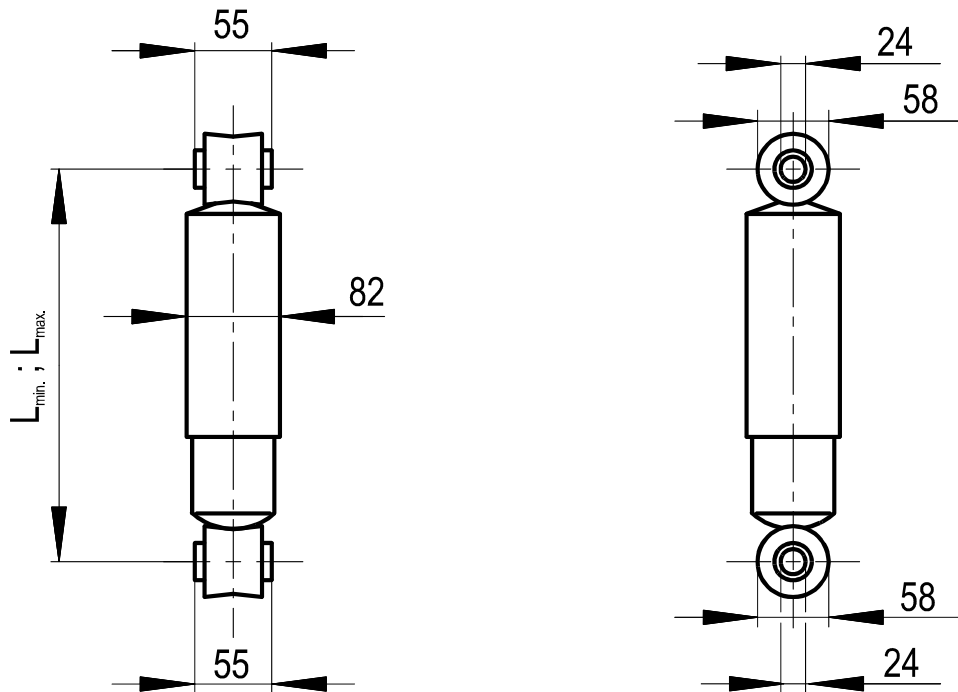

Order number:	Stroke [mm]	L <sub>min.</sub> [mm]	L <sub>max.</sub> [mm]	Characteristics tension/compression [N] at 0,52 m/s
2 376 0026 00	170	325	495	18500 / 4000
2 376 4026 00 (heavy duty version)	170	325	495	24000 / 3200
2 376 0027 00	140	292	424	18500 / 4000
2 376 4027 00 (heavy duty version)	140	292	424	24000 / 3200
2 376 0030 00	160	315	475	19000 / 4300
2 376 0031 00	190	350	540	19800 / 5100
2 376 0032 00	270	426	696	18500 / 5000
2 376 0036 00	320	475	795	17000 / 6500

### Calculation of free space between tyre and air bag.

The calculated clearance is the distance between tyre and air bag. This must be at least **25 mm**.

Calculation formula: 
$$\frac{AX - LM - \text{air bag diameter} - \text{tyre width}}{2} + V - ET \geq 25 \text{ mm}$$

As example the suspension:

M36/2500S27 S11-4220  
 distance wheel attachment faces: 2040 mm  
 spring centre: 1200 mm  
 air bag diameter 350 mm  
 mounted tyre 425/65R22,5"  
 (E.T.R.T.O. Norm 447 mm)  
 air bag offset 30 mm  
 offset 0 mm

U27/2910EN29 ZI9-19K  
 distance wheel attachment faces: 1860 mm  
 spring centre 980 mm  
 air bag diameter 300 mm  
 mounted tyre 265/70R19,5"  
 (E.T.R.T.O. Norm 272 mm)  
 air bag offset 30 mm  
 used wheel 19,5 x 7,50 (example ET 138,5 mm)

$$\frac{2040 - 1200 - 350 - 438}{2} + 30 - 0 = 51,5 \text{ mm}$$

$$\frac{1860 - 980 - 300 - 272}{2} + 30 - 138,5 = 45,5 \text{ mm}$$

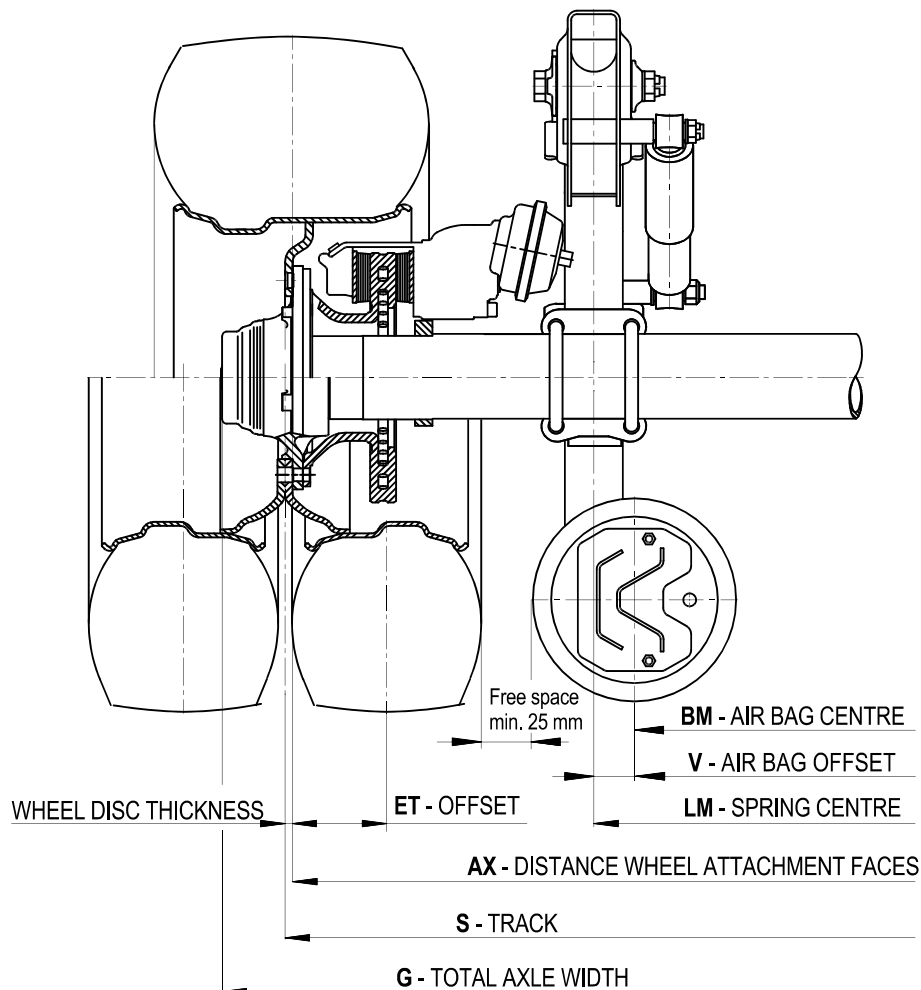

### Air bag overview

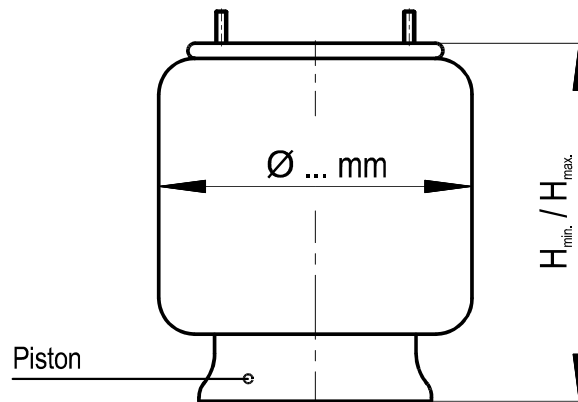

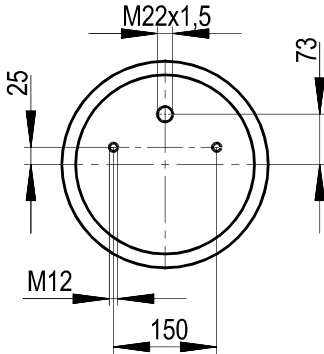
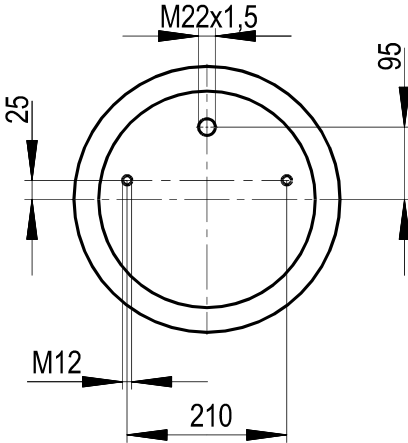
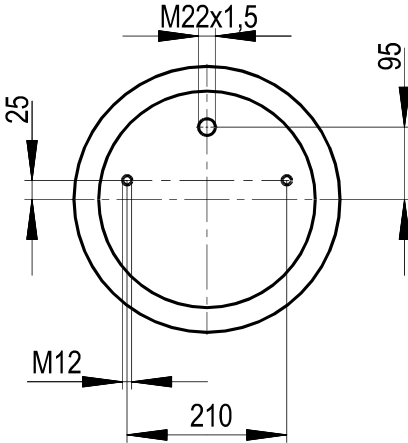
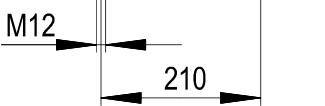
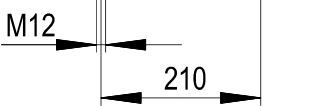
Description	Article number. - code:	Top view
2618V $H_{min} = 180 \text{ mm}$ $H_{max} = 550 \text{ mm}$ $\varnothing 300 \text{ mm}$ plastic piston	3 228 0029 00 - <b>29</b>	
2918V $H_{min} = 180 \text{ mm}$ $H_{max} = 520 \text{ mm}$ $\varnothing 350 \text{ mm}$ steel piston	3 228 0027 00 - <b>27</b>	
2919V $H_{min} = 180 \text{ mm}$ $H_{max} = 520 \text{ mm}$ $\varnothing 350 \text{ mm}$ plastic piston	on request, depending on air bag offset (V) - <b>42</b>	
2923V $H_{min} = 225 \text{ mm}$ $H_{max} = 625 \text{ mm}$ $\varnothing 350 \text{ mm}$ steel piston	3 228 0031 00 - <b>31</b>	
2924V $H_{min} = 225 \text{ mm}$ $H_{max} = 625 \text{ mm}$ $\varnothing 350 \text{ mm}$ plastic piston	on request, depending on air bag offset (V) - <b>41</b>	

### Calculation of the air bag pressure

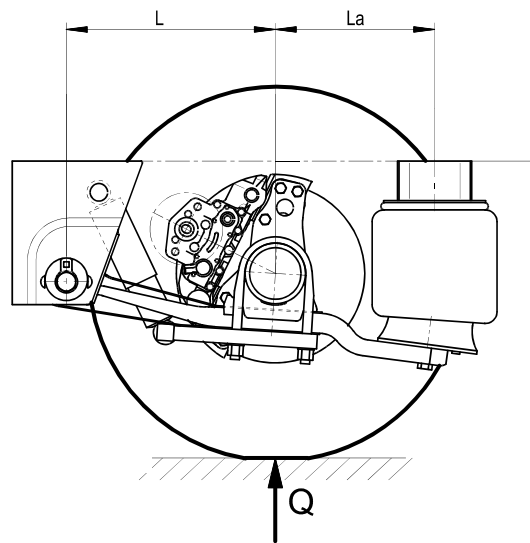

**Formula to calculate the air pressure when fully loaded:**

$$P = \frac{(Q - A) * i * p}{2} * 10^5 \text{ Pa} \quad (1 \text{ bar} = 10^5 \text{ N/m}^2 = 10^5 \text{ Pa} = 0,1 \text{ MPa})$$

P = air pressure in the air bag ( Pa )

Q = permissible axle load on the ground ( kg )

A = unsprung mass ( kg ) mean value for

$$A = Q \times 0,1$$

i = ratio

$$i = \frac{L}{L + La}$$

p = air pressure in the air bag per kg load.

air bag Ø 300mm (SAF 2618V)

$$p = 0,00227 * 10^5 \text{ Pa/kg}$$

air bag Ø 350mm (SAF 2918V / 2919V / 2923V / 2924V)

$$p = 0,0018 * 10^5 \text{ Pa/kg}$$

**Example:**

Air suspension type: M36/2500EN29 (air bag SAF 2618V)

Q = 9000 kg

$$A = Q \times 0,1 = 900 \text{ kg}$$

L = 500 mm , La = 385 mm

$$i = \frac{500}{500 + 385} = 0,565$$

p = 0,00227 \* 10<sup>5</sup> Pa/kg

$$P = \frac{(9000 - 900) * 0,565 * 0,00227}{2} * 10^5 \text{ Pa}$$

**P = 5,2 \* 10<sup>5</sup> Pa**

**Formula to calculate the air pressure when partially loaded:**

$$P_t = \frac{(Q_t - A) * i * p}{2} * 10^5 \text{ Pa}$$

Q<sub>t</sub> = axle load on the ground when partially loaded

**Example:**

Air suspension type: M36/2500EN29 (air bag SAF 2618V)

Q = 9000 kg

$$A = Q \times 0,1 = 900 \text{ kg}$$

Q<sub>t</sub> = 2100 kg

L = 500 mm, La = 385 mm

$$i = \frac{500}{500 + 385} = 0,565$$

p = 0,00227 \* 10<sup>5</sup> Pa/kg

$$P_t = \frac{(2100 - 900) * 0,565 * 0,00227}{2} * 10^5 \text{ Pa}$$

**P<sub>t</sub> = 0,77 \* 10<sup>5</sup> Pa**

**Pressure-force diagram for air bag with diameter 300 mm**

**Air bag: SAF 2618V (29)**

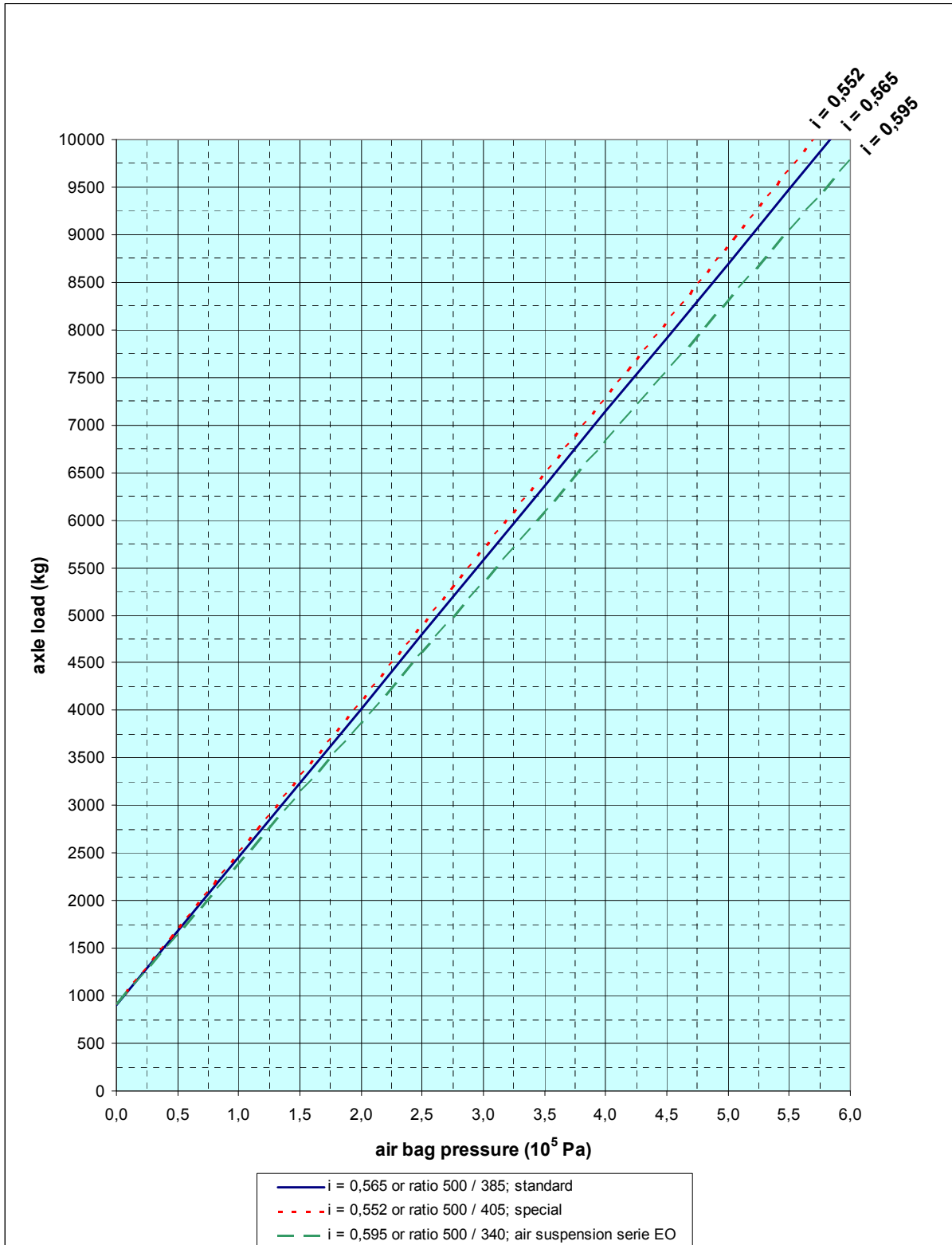

**Pressure-force-diagram for air bag with diameter 350 mm**

- Air bags:** SAF 2918V (27)  
 SAF 2923V (31)  
 SAF 2924V (41)  
 SAF 2919V (42)

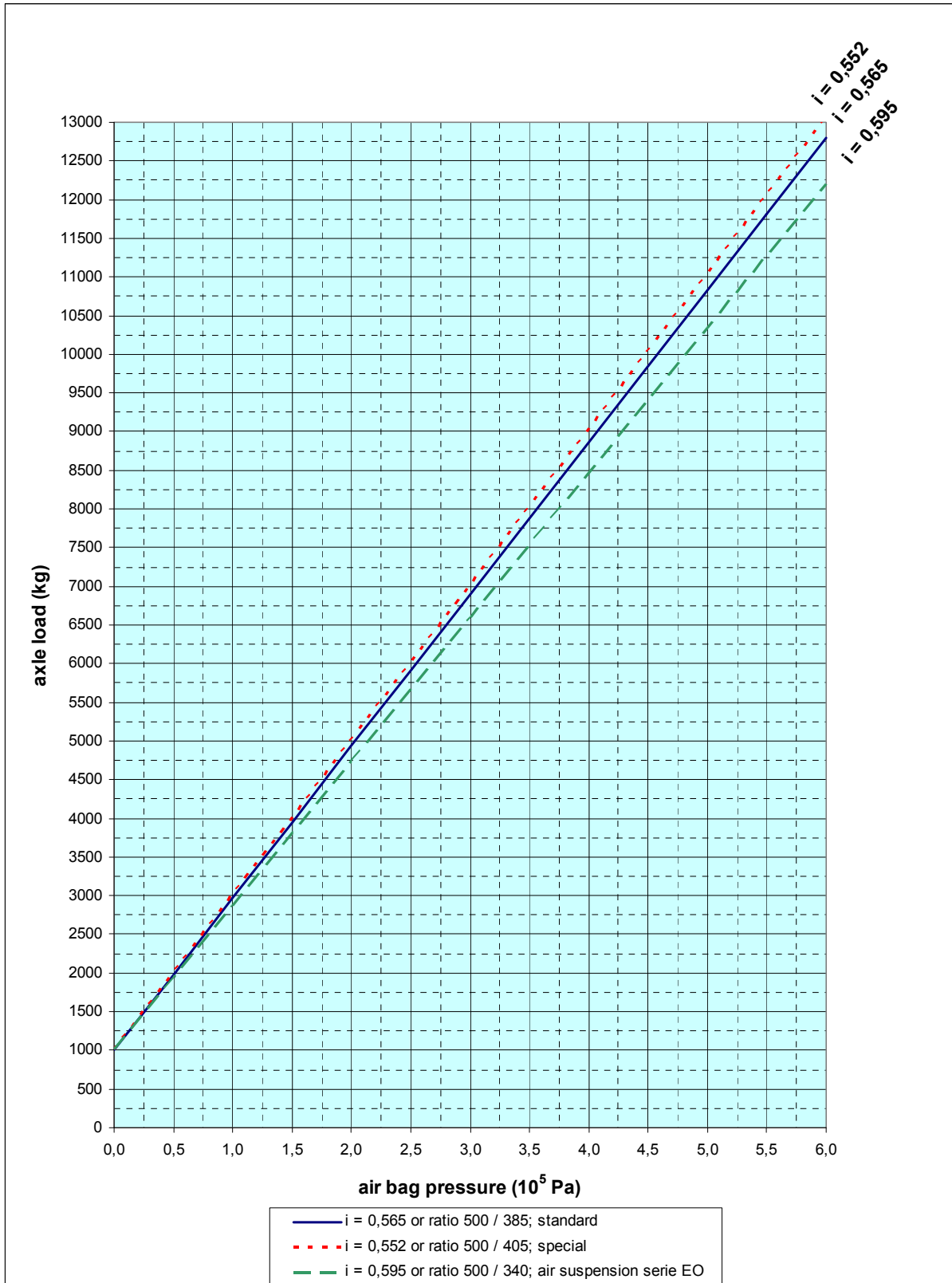



**Mounting plates for air bag offset (V) overview**

air bag offset (V)	standard	La +20 mm
0 mm		
	1 043 0291 00	1 043 0345 00
30 mm		
	1 043 0292 01	left – 1 043 0307 00 (shown) right – 1 043 0308 00 (mirrored)
55 mm		
	left – 1 043 0328 00 (shown) right – 1 043 0327 00 (mirrored)	left – 1 043 0369 00 (shown) right – 1 043 0370 00 (mirrored)
70 mm		
	left – 1 043 0289 00 (shown) right – 1 043 0290 00 (mirrored)	left – 1 043 0401 00 (shown) right – 1 043 0402 00 (mirrored)

Amendments and errors excepted. XL-AS10004DM-en-DE Rev B © SAF-HOLLAND

### Overview air bag brackets

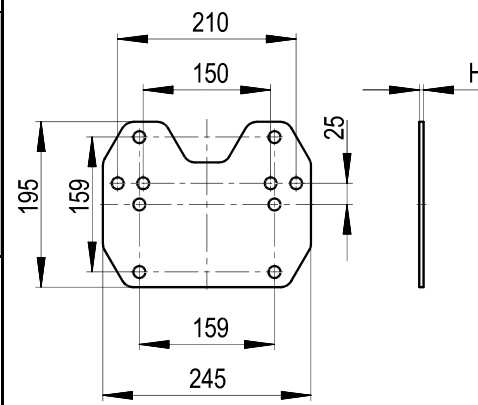
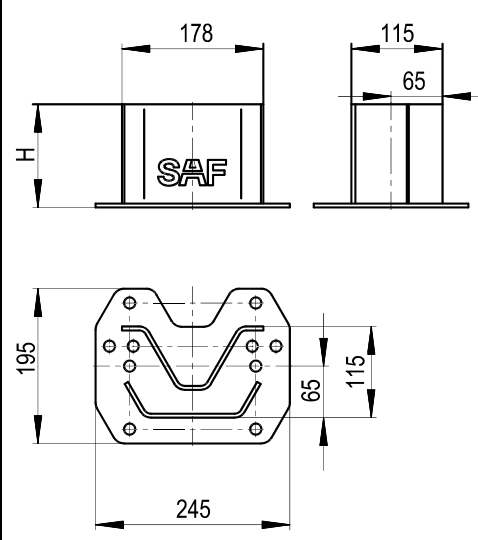
article number:		H [mm]	description	
primed	non-primed			
1 043 0261 01	1 043 0261 91	5	mounting plate „steel“	
1 043 0262 01	1 043 0261 01	8	mounting plate „aluminium“	
2 237 0070 01	2 237 0070 91	40	air bag bracket „steel“	
2 237 0081 01	2 237 0081 91	50		
2 237 0071 01	2 237 0071 91	70		
2 237 0080 01	2 237 0080 91	100		
2 237 0072 01	2 237 0072 91	130		
2 237 0073 01	2 237 0073 91	160		

## Surface coating of SAF components

### Corrosion protection of SAF products:

- Axle beams and brake chamber with cathodic hot-dip coating, alternatively 2-component coating, colour black RAL 9005.
- All bolts and fittings with dacromet coating, colour grey metallic.
- Front hanger brackets with 2-component coating, colour black RAL 9005.
- Wheel attachment face: thin cathodic hot-dip coating, coat thickness <25 µm colour black RAL 9005, alternatively transparent temporary corrosion protection (not to remove before mounting of a wheel).

### Cathodic dip coating (KTL):

The coat thickness is max. 45 µm.

Features:

- Complete corrosion protection in all areas of the component.
- Great surface hardness with uniform coat thickness.
- Can be painted over with all single-component or 2-component top coats.
- Protection min. 504 h. salt spray test to DIN 50021.

### 2-component coating

Primer coat for additional top coat.

Coat thickness is max. 45 µm.

Protection min. 504 h. salt spray test to DIN 50021.

### Dacromet coating

Corrosion protection with sliding properties

Protection min. 504 h in salt spray test to DIN 50021

### Treatment during axle and suspension installation:

- In principle, dip coating and 2-component primers can be welded. SAF recommends, however, that these coats be removed in the area of weld seams.
- All contact surfaces of the pivot bolts and shock absorbers bolts must not have additional primer or paint coatings.
- Wheel attachment faces must not be painted. The surfaces must be clean and free of grease. In general the remarks of the wheel manufactures need to be followed.

## Two side axle lift for axles with drum brake

For axles with disc brake on request.

We recommend a minimum of **100 mm** lift travel when setting the ride height. Use of 19,5" tyres possible in combination with two sided axle lift if the clearance to the ground is taken into account. With installation of a two sided axle lift a minimum distance of **15 mm** between lift air bag and brake drum are to be considered.

### Calculation of clearance between lift air bag and tyre

The clearance must be at least **25 mm**.

Formula:

$$\frac{AX - LM - \text{max. tyre width} - 270}{2} + 15 \geq 25\text{mm}$$

Example with: M36/2500EN29 S9-4218

- distance wheel attachment faces: 2040 mm
- spring centre: 1300 mm
- tyre width (max.): 405 mm (E.T.R.TO. Norm for tyre 385/65R22,5")
- lift air bag diameter 270 mm
- lift air bag offset 15 mm

$$\frac{2040 - 1300 - 405 - 270}{2} + 15 = 47,5 \geq 25\text{ mm}$$

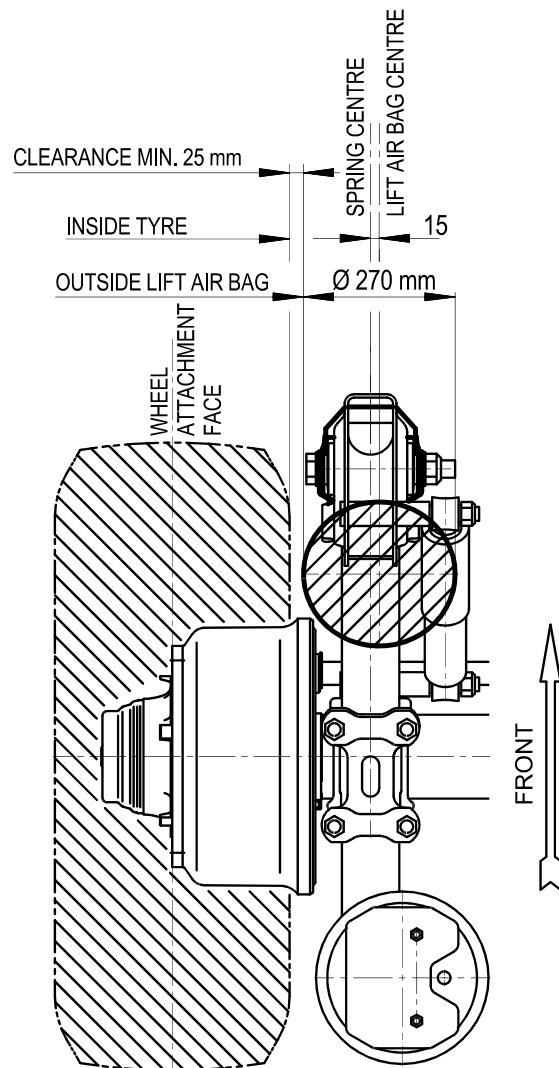

Installation combination of the two side axle lift for modul series with single leaf trailing arm.

Single tyre 22,5"				
AX [mm]	LM [mm]	lift air bag centre [mm]	tyre size (example)	
			385/65R22,5"	425/65R22,5"
1970	1200	1170	XXX	XXX
2040	1200	1170	XXX	XXX
2040	1300	1270	XXX	XXX
2090	1300	1270	XXX	XXX
2090	1400	1370	XXX	not possible
2140	1400	1370	XXX	XXX

Other axle combinations must be checked.

**Two side axle lift types**

For axles with drum brake SNK 420, single tyre and single leaf trailing arm

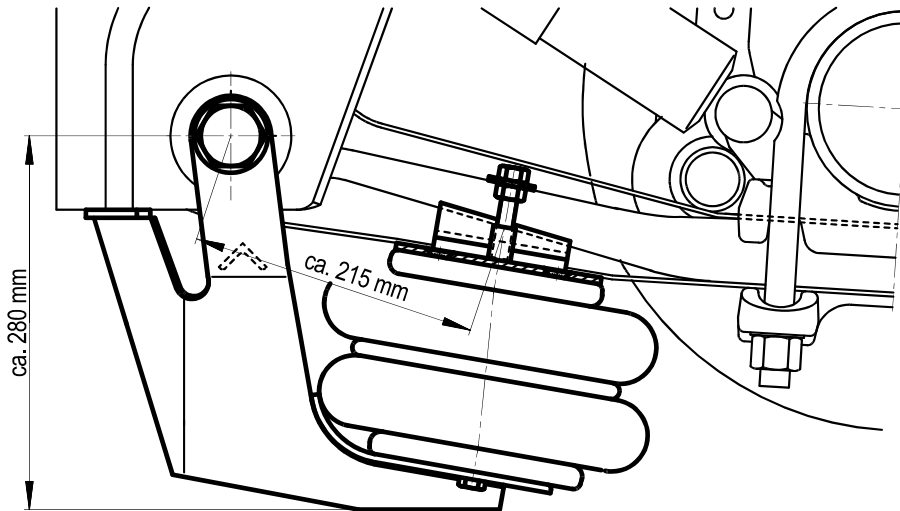

**air suspension serie „U../....EN..“**

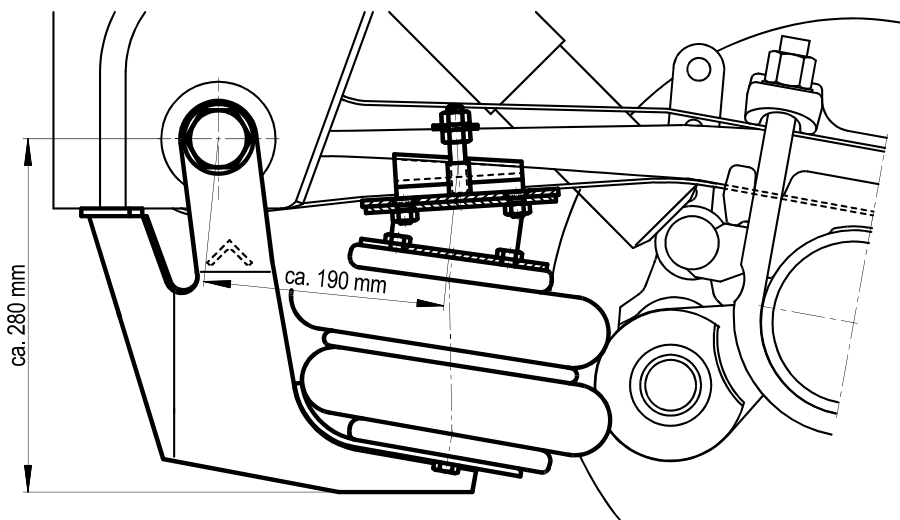

**air suspension serie „M../....EN..“**

Following types are obtainable:

kit number:	air suspension serie	application
3 027 1205 01	U../....EN..	for hanger bracket „steel“
3 027 1216 01	U../....EN..	for cross member
3 027 1236 00	M../....EN..	for hanger bracket „steel“
3 027 1237 00	M../....EN..	for cross member

Further variants on request

Weight per axle approx. 30 kg (2 kits).







**Pendulum lift**

For suspension serie „U“, „M“ and „EO“ with single- and double leaf trailing arm.

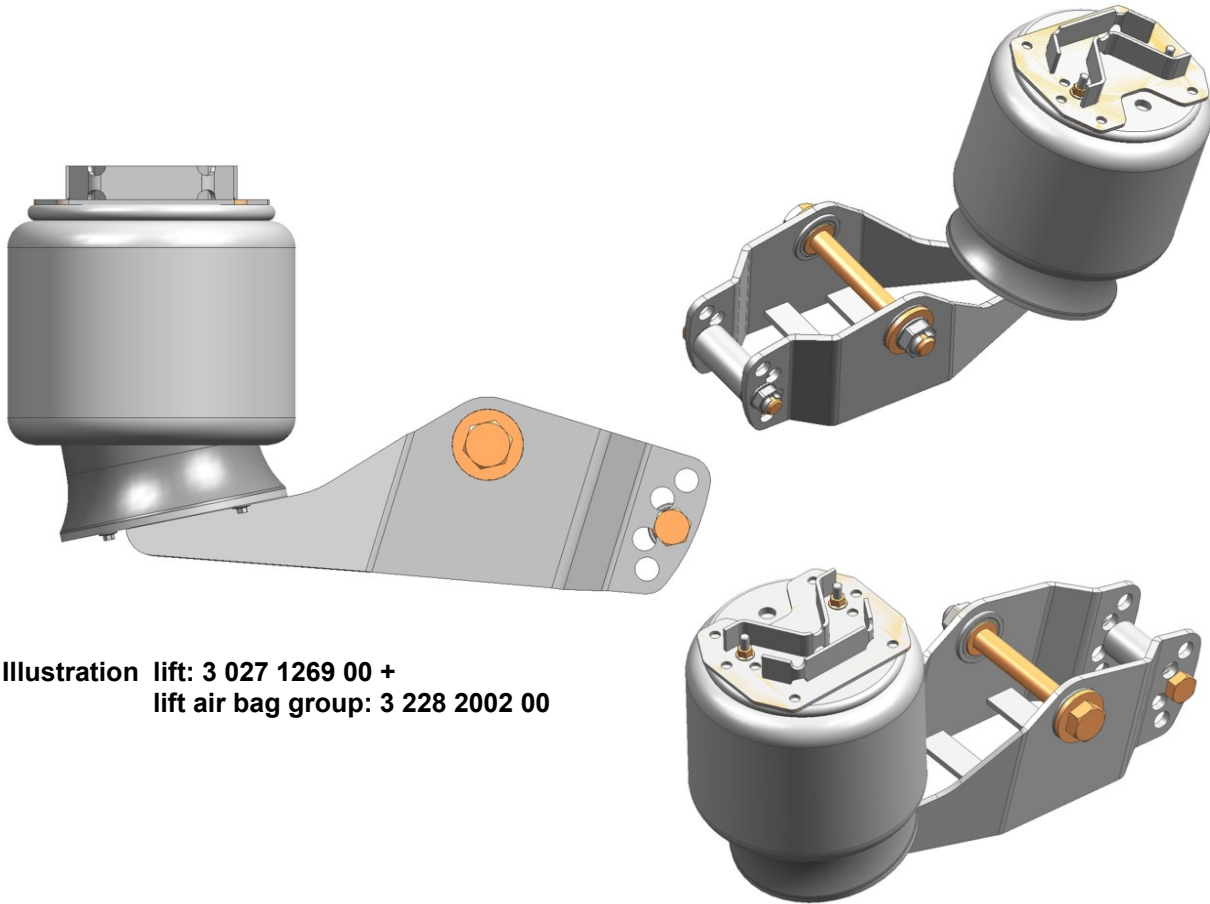

**Illustration lift: 3 027 1269 00 +  
lift air bag group: 3 228 2002 00**

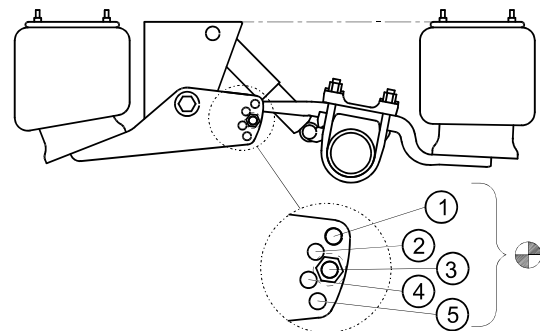
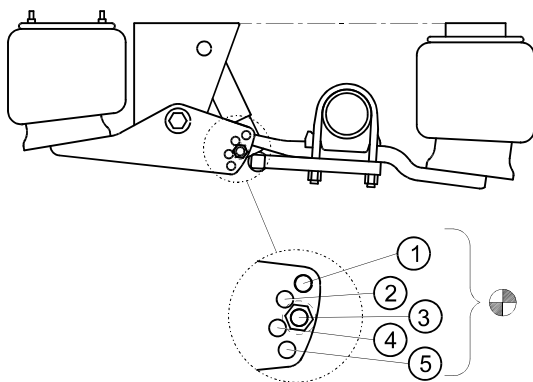

The mounting position ( ⊕ ) for the supporting roll is to be taken from the respective suspension drawing.

Weight starts at 27 kg.

**Note:**

We recommend a minimum of **100** mm lift travel when setting the ride height.

Not applicable with use of cross member or hanger bracket „aluminium“.

Avoid any collision of the lift arm to the hanger bracket lateral reinforcement.



## Kit content pendulum lift

A lift kit contains 1 kit + 1 lift air bag combination group.

kitnumber:	3 027 1269 00	pos.	pro kit
lift arm	2 239 0043 00	(6)	1x
hexagon screw M30x260	4 343 1049 88	(1)	1x
hexagon nut M30	4 247 4022 80	(5)	1x
pilot bush	1 148 1005 00	(2)	2x
hexagon screw M24x160	4 343 2058 88	(7)	1x
supporting roll	2 309 3032 00	(8)	1x
hexagon nut M24	4 247 4040 80	(9)	1x
<b>+ lift air bag combination group:</b>			
lift air bag	3 229 0029 00	(10)	1x
self cutting screw K100x40	4 343 2037 00	(11)	3x
hexagon screw M12	4 247 4047 10	(12)	2x
air bag bracket or mounting plate	depending on air suspension type	(13)	1x

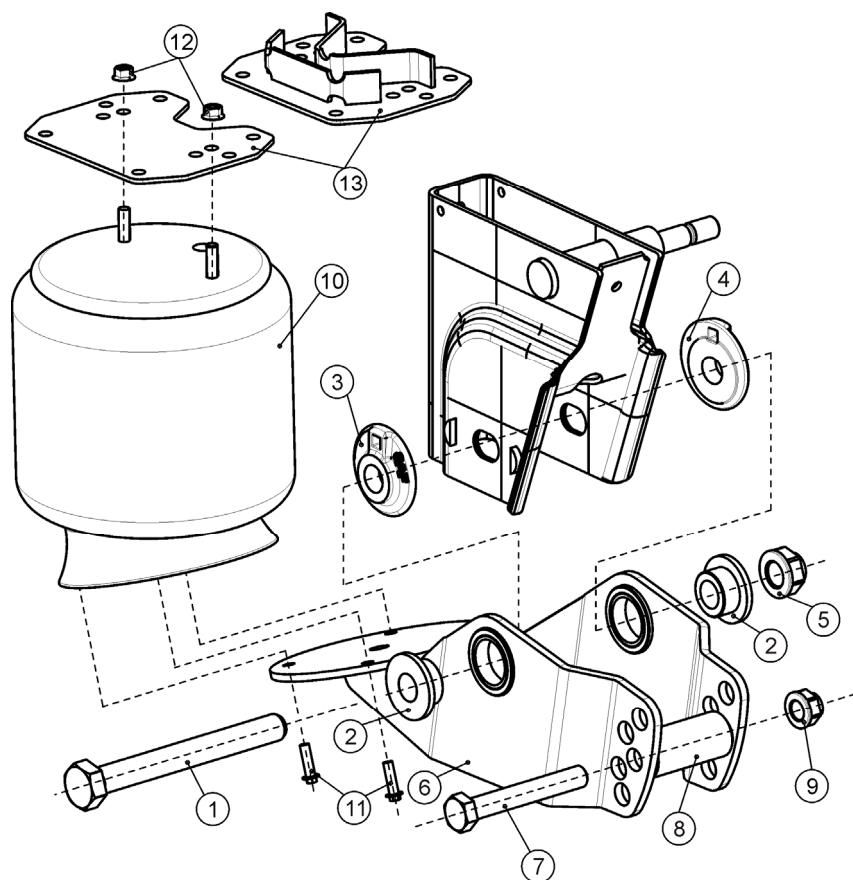

### Installation instruction

#### Installation of the supporting roll (8):

Choose the right position.  
(on request) Mount the supporting roll (8) with screw (7) and lock nut (9).

**Tightening torque 420 Nm.**

#### Installation of the lift arm (6):

- ✓ Remove the existing pivot bolt mounting. Eccentric washer (3) and thrust washer (4) re-use.
- ✓ Position the lift arm (6) over the hanger bracket and place the supporting roll to the trailing arm. (without picture).
- ✓ Fasten the pivot bolt according to the illustration. Use het hexagon screw (1), pilot bushes (2) and lock nut (5) new from the kit. Washers (3) and (4) of the demounting.
- ✓ **Important: the pivot bolt must be tightened according to the SAF-HOLLAND torque regulations in the ride height. (400 Nm + 120°, see Page 89)**

#### Installation of the lift air bag (10):

- ✓ Apply the mounting plate respectively air bag bracket (13) to the trailer. (see [Page 88](#) resp. suspension drawing)
- ✓ Fasten the lift air bag (10) with the screws (11) to the lift arm (6). **Tightening torque 20 Nm.**
- ✓ Fasten the lift air bag (10) to the mounting plate resp. air bag bracket (13) by the top bolts with the hexagon screws (12). **Tightening torque 40 Nm.** Take hereby note to the position of the air intake port.
- ✓ Circuit diagram see [Page 84](#)

### Centre axle lift

For suspension series U with single- and double leaf trailing arm

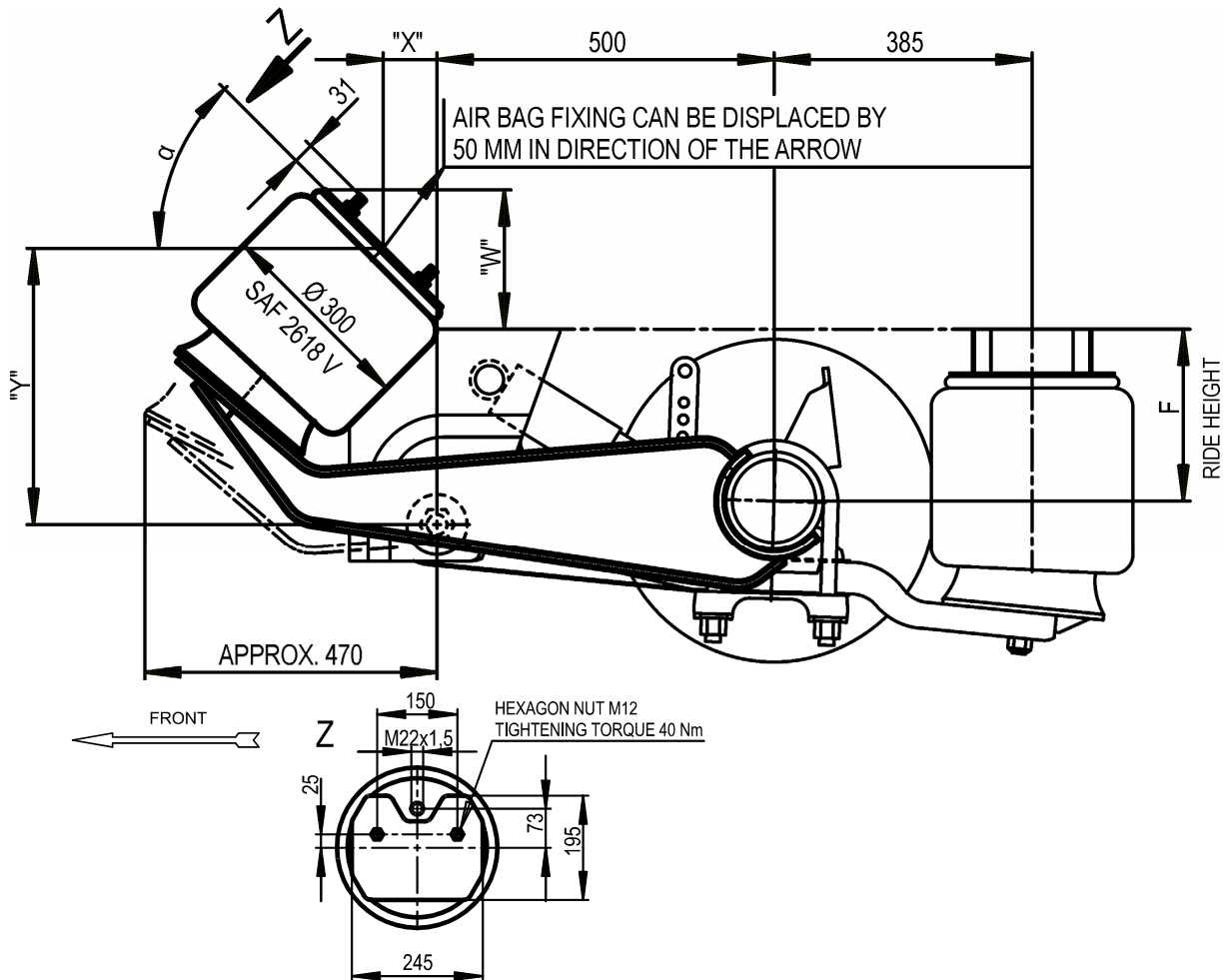

Weight starts at approx. 32 kg

We recommend a minimum of **100 mm** lift travel when setting the ride height.

Option: lift air bag Ø 350 mm (SAF 2918V) on request.

air suspension type	dimension				with mounting plate "steel"		with mounting plate "aluminium"	
	"X" [mm]	"Y" [mm]	"α" [mm]	"W" approx. [mm]	axle beam Ø 146 mm	axle beam Ø 127 mm	axle beam Ø 146 mm	axle beam Ø 127 mm
U20/2500_29	90	400	45°	240	1193	1192	1219	1218
U22/2504_29	80	410	45°	250				
U24/2904_29	90	400	45°	200				
U25/2907_29	80	410	45°	210				
U27/2910_29	70	420	45°	220				
U30/3510_29	90	400	45°	135				
U31/3513_29	80	410	45°	145				
U33/3516_29	70	420	45°	155				
U23/2500_31	50	415	50°	260	1193	1192	1219	1218
U25/2504_31	40	420	50°	265				
U27/2904_31	50	415	50°	220				
U28/2907_31	40	420	50°	225				
U30/2910_31	35	430	50°	235				
U33/3510_31	50	415	50°	155				
U35/3513_31	40	420	50°	160				
U36/3516_31	35	430	50°	170				

### Centre axle lift

For suspension serie M with single- and double leaf trailing arm.

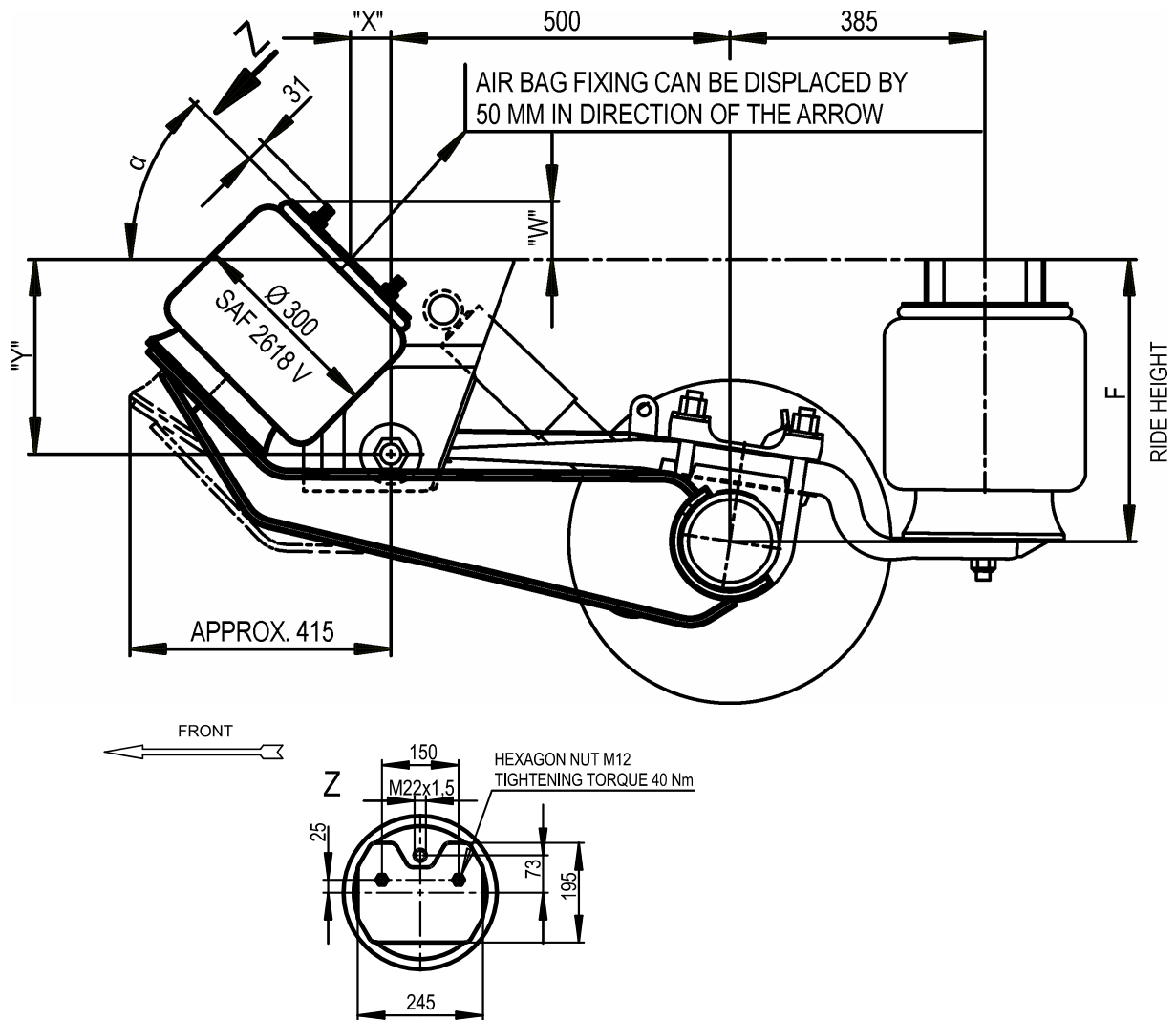

Weight starts at approx. 32 kg

We recommend a minimum of **100 mm** lift travel when setting the ride height.

Option: lift air bag Ø 350 mm (SAF 2918V) on request.

air suspension type	dimension				with mounting plate "steel"		with mounting plate "aluminium"	
	"X" [mm]	"Y" [mm]	"a" [mm]	"W" approx. [mm]	axle beam Ø 146 mm	axle beam Ø 127 mm	axle beam Ø 146 mm	axle beam Ø 127 mm
M36/2500_29	65	285	45°	125	1193	1192	1219	1218
M38/2504_29	60	290	45°	130				
M40/2904_29	65	285	45°	85				
M42/2907_29	60	290	45°	90				
M43/2910_29	55	295	45°	95				
M46/3510_29	65	285	45°	20				
M40/2500_31	45	305	45°	145	1193	1192	1219	1218
M42/2504_31	40	310	45°	150				
M43/2904_31	45	305	45°	105				
M45/2907_31	40	310	45°	110				
M47/2910_31	35	315	45°	115				
M50/3510_31	45	305	45°	40				

### Circuit diagram, one sided or pendulum lift

Triaxle with lift (one sided or pendulum lift) and lift axle control valve (pneumatically controlled)

00 53 34 4 01 5 composed of:	
quantity	kitnumber
1 x	3 425 0001 00
1 x	3 425 0003 00

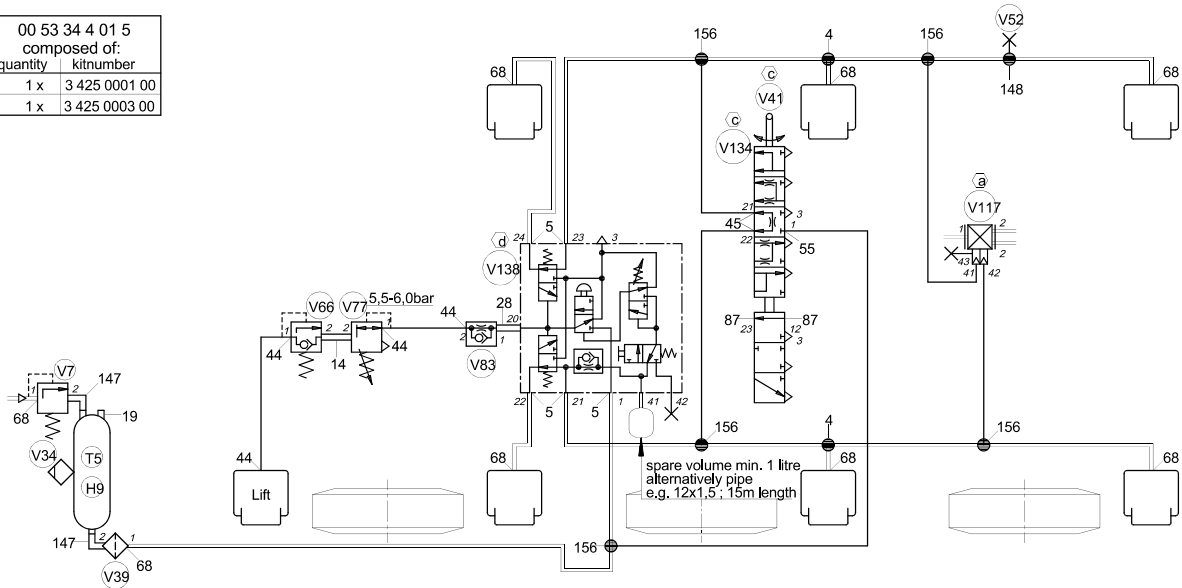

remarks to index no.	explanations
a) =not our delivery volume ( . . . . . 99 ) c) =mounted to middle axle d) =2,5 - 7 bar, working range, adjust to air bag pressure at nominal axle load. (+0,3bar tolerance)	=Rohr 8*1 =Rohr 12*1,5 connexion designation at valve fitting 4 424 0068 00 valve V 4 425 0007 00
according to DIN 34 all rights reserved!	circuitnumber 00 53 34 4 01 5

**max. lift air bag pressure 6,0 bar; residual pressure 0,5 bar!**

Reference no. → 00 53 34 4 01 5 → composed of

SAF KIT Basic 3 425 0001 00	quantity	SAF KIT 1SL 3 425 0003 00	quantity	description	dimensions	WABCO ref.
SAF reference 4.424.0004.40	2	4.424.0004.40	1	EQUAL TEE COUPLING	D12/12/12	893 861 450 0
		4.424.0005.40	5	STRAIGHT MALE STUD COUPLING	M16x1,5/D12	893 803 430 0
		4.424.0014.40	1	DOUBLE CONNECTOR WITH LOCK NUT	M22x1,5	893 890 440 0
4.424.0019.40	1			MALE PLUG	M22x1,5	893 022 009 4
4.424.0044.40	1	4.424.0028.40	1	DOUBLE CONNECTOR	M22x1,5	893 890 440 0
4.424.0045.40	2	4.424.0044.40	4	STRAIGHT MALE STUD COUPLING	M22x1,5/D8	893 803 400 0
4.424.0055.40	1			STRAIGHT MALE STUD COUPLING	M12x1,5/D8	893 803 490 0
4.424.0068.40	7			MALE STUD ELBOW COUPLING	M12x1,5/D8	893 831 240 0
4.424.0087.40	2	4.424.0068.40	1	STRAIGHT MALE STUD COUPLING	M22x1,5/D12	893 803 440 0
4.424.0147.40	2			MALE PLUG	M16x1,5	893 022 008 4
4.424.0148.40	1			ELBOW WITH LOCK NUT	M22x1,5	893 890 641 0
4.424.0156.40	4	4.424.0156.40	1	MALE STUD TEE COUPLING	M22x1,5/D12/D12	893 850 970 0
V 4.425.0007.00	1			EQUAL TEE COUPLING	D12/8/12	
V 4.425.0034.40	1			CHARGING VALVE WITHOUT RETURN FLOW 6,0 BAR	M22x1,5	434 100 125 0
V 4.425.0039.00	1			DRAIN VALVE	M22x1,5	934 300 001 0
V 4.425.0041.00	1			LINE FILTER	M22x1,5	432 500 020 0
V 4.425.0052.00	1			LINK CONNECTION FOR LEVELLING VALVE	M8/D6	433 401 003 0
				TEST COUPLING	M22x1,5	463 703 117 0
		V 4.425.0066.00	1	CHARGING VALVE WITH RETURN FLOW 0,5 BAR	M22x1,5	434 100 027 0
		V 4.425.0077.00	1	PRESSURE LIMITING VALVE 1,8 BAR	M22x1,5	475 010 307 0
		V 4.425.0083.00	1	CHECK VALVE CONSTANT THROTTLING D1	M22x1,5	434 014 001 0
V 4.425.0117.99	(1)			LOAD SENSING VALVE		475 714 500 0
V 4.425.0134.00	1			LEVELLING VALVE	M12x1,5/M16x1,5	464 006 100 0
		V 4.425.0138.00	1	LIFT AXLE CONTROL VALVE	M16x1,5/M22x1,5	463 084 000 0
T 4.105.0005.00	1			AIR RESERVOIR 60 LTR	D276x1100	950 760 002 0
H 4.405.0009.00	2			HOLDER (AIR RESERVOIR) 40/60 LTR	D276	451 999 276 2

□ = not SAF delivery volume.  
 ▲ = do not belong to a SAF-KIT.

## Welding instruction for hanger bracket „steel“

### Note

Cover the trailing arm, to protect it from flying sparks. Welding and connecting the welding equipment ground cable to the trailing arm is not permissible. In order to avoid bearing damage, the welding equipment ground cable must also not be connected either to the wheel, wheelhub or wheelflange.

### Welding recommendation

The high tensile steel used for the hanger brackets with a carbon content of max. 0,2 % can easily be welded. SAF-HOLLAND is using the gas metal arc welding procedure with the additional material G4 Si 1 (previous designation SG 3) in accordance with DIN EN 440, for steel S 235 to S 335, weldable fine-grained structural steel to S 460.

Shielding gas in accordance with DIN EN 439, welding seams to DIN EN 5817 "quality levels for imperfections" to "group C".

WELDING SEAM 5 

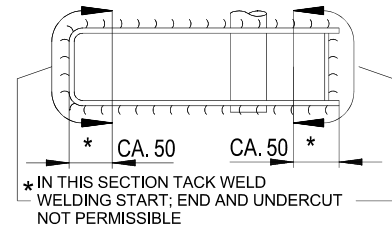

### Design information

The chassis must be reinforced so that it can absorb the forces to which it is exposed. The hanger brackets need an additional reinforcement.

### Recommendation for lateral reinforcement of the hanger brackets

Overlapping of the lateral brace (gusset plate) and inner brace plate of the hanger bracket is necessary to avoid any diaphragm effect. The use of a cross member can replace the lateral brace, but this doesn't replace a crossmember in the chassis.

Geometry dimensions of the hanger bracket, see [page 58](#).

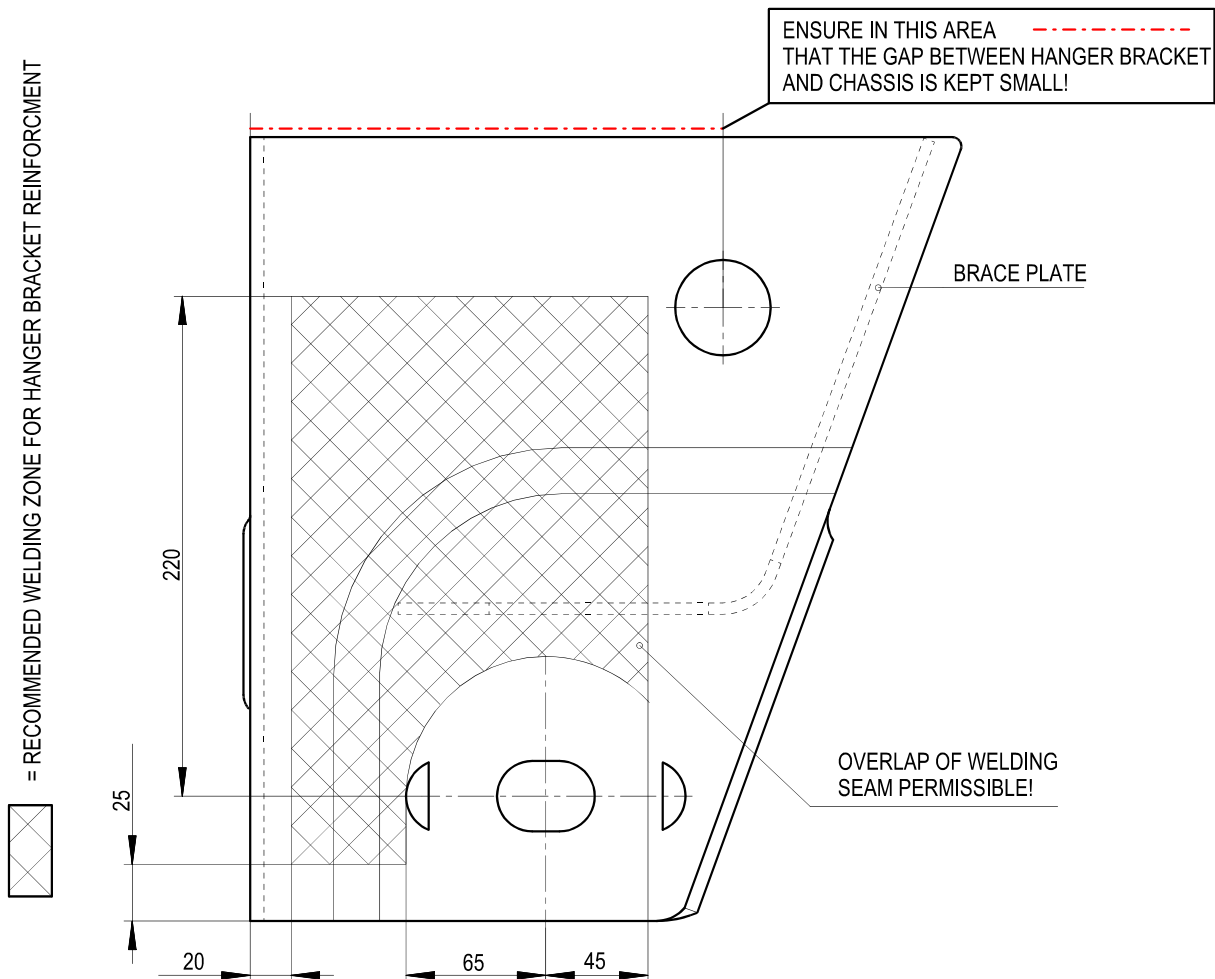

## Welding instruction for hanger bracket „aluminium“

### Note

Cover the trailing arm to protect it from flying sparks. Welding and connecting the welding equipment ground cable to the trailing arm is not permissible. In order to avoid bearing damage, the welding equipment ground cable must also not be connected either to the wheel, wheelhub or wheelflange.

### Material

Al Mg 4,5 Mn W 28 (W=soft; 28=tensile strength Rm min. 275 N/mm max. 350 N/mm)

### Welding recommendation

Pre-treat welding edges with steel brush (brushes with CrNi-steel). They should not be polished (misguides the arc). The welding seam should be kept as narrow as possible (SAF recommends a = 7 mm, chamfer 5 x 30°), to minimise the heat-induced distortion and tension.

SAF is using the gas metal arc welding procedure with the additional material SG – Al Mg 4,5 in accordance with DIN EN ISO 18273.

Shielding gas “Argon” in accordance with DIN EN ISO 14175, welding seams to DIN EN 25817 “quality levels for imperfections” to “group C”.

WELDING SEAM 7 mm  $\nabla$

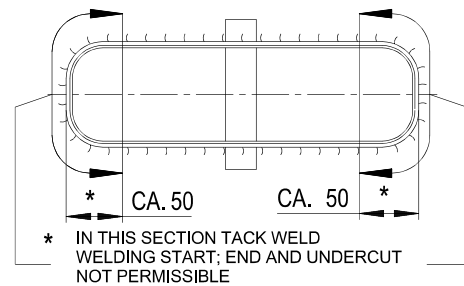

### Design information

The chassis must be reinforced so that it can absorb the forces to which it is exposed. The hanger brackets need an additional reinforcement.

### Recommendation for lateral reinforcement of the hanger brackets

Overlapping of the lateral brace (gusset plate) and inner brace plate of the hanger bracket is necessary to avoid any diaphragm effect.

Geometry dimensions of the hanger bracket, see [page 64](#)

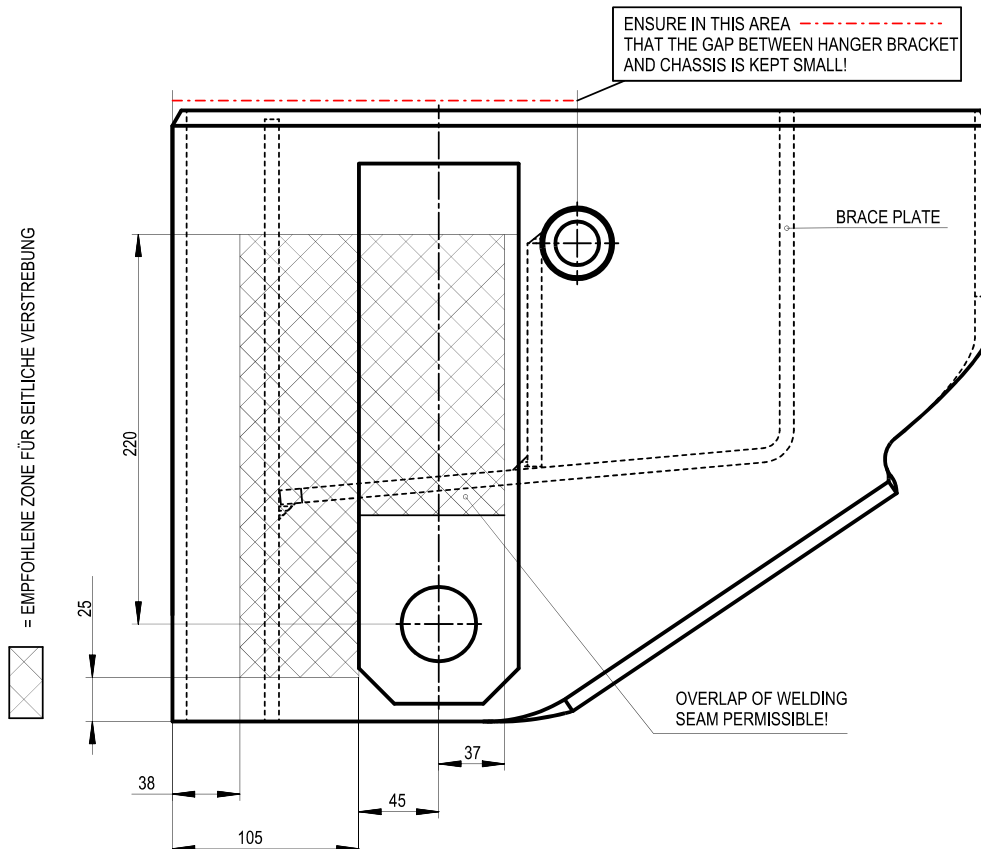

**Recommendation for lateral reinforcement of hanger bracket „steel“  
for torsionally flexibel chassis**

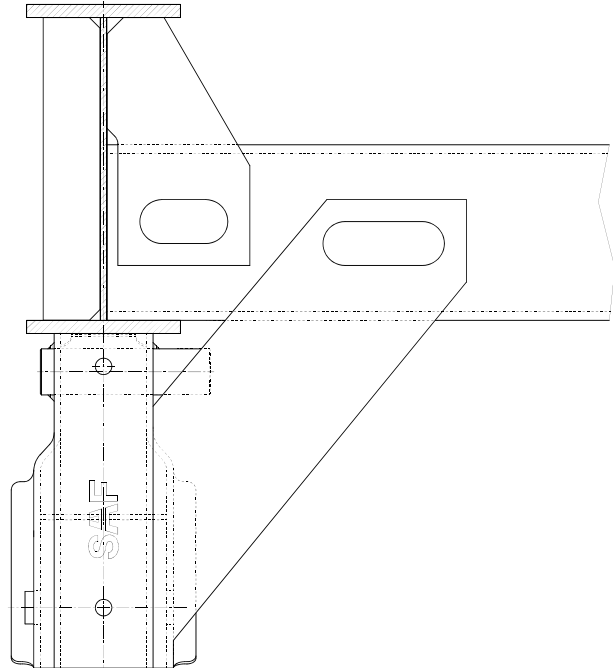
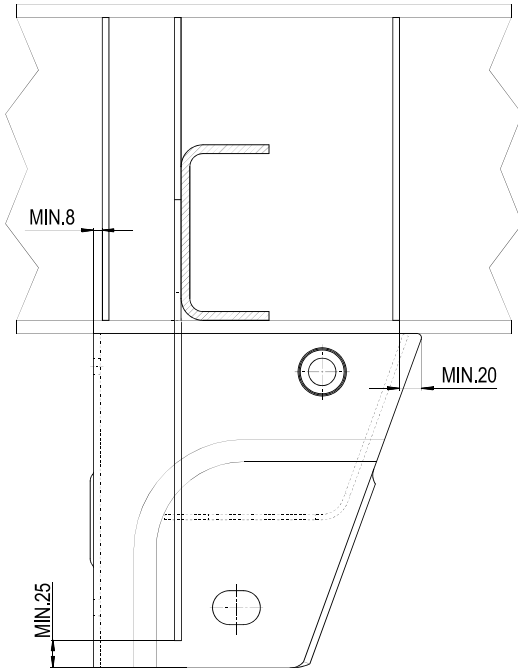

Ref. Nr.: Verstrebung\_Modul01

**for torsionally stiff chassis**

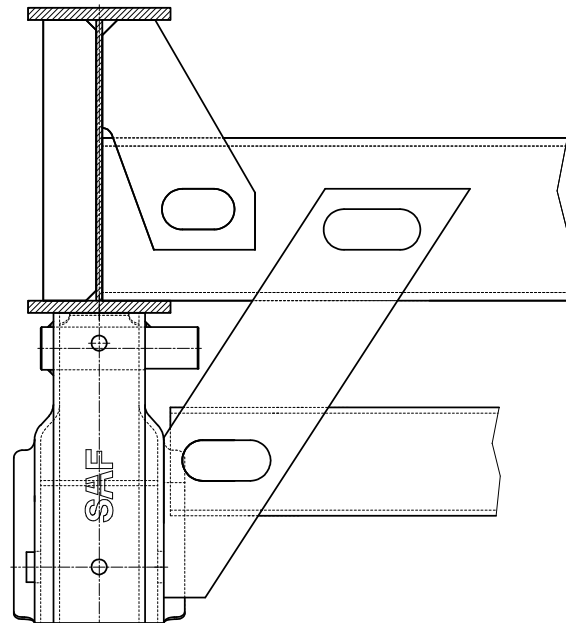
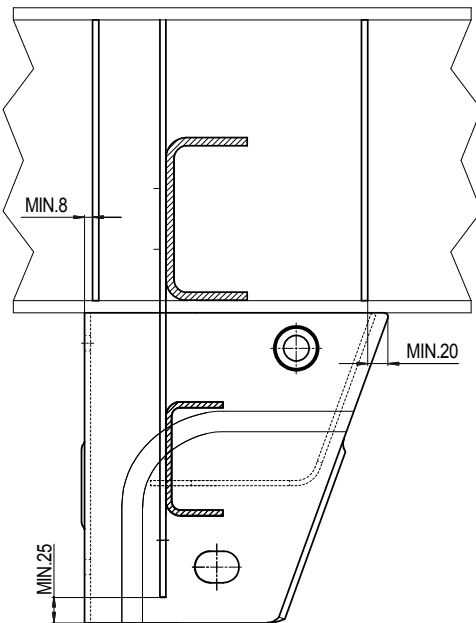

Ref. Nr.: Verstrebung\_Modul02

Hanger bracket welding instruction see [page 79](#).  
The design and dimensioning of the hanger bracket reinforcement is the responsibility of the trailer manufacturer, this depends on the type and operating conditions of the trailer.

### Welding instruction for air bag bracket

Welding seam course and bracing are SAF-recommendations. Dimensions, design and implementation are under responsibility of the trailer manufacturer.

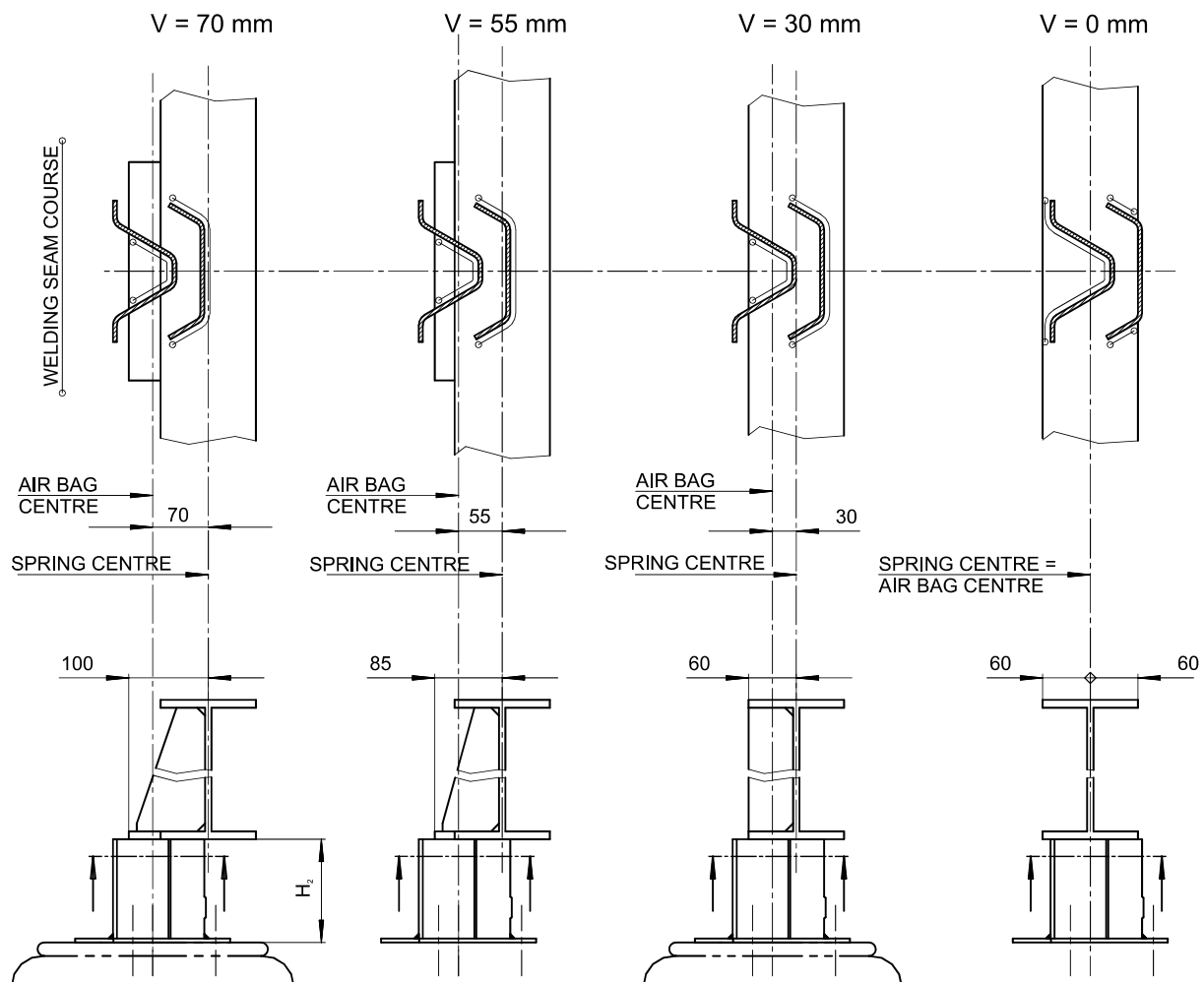
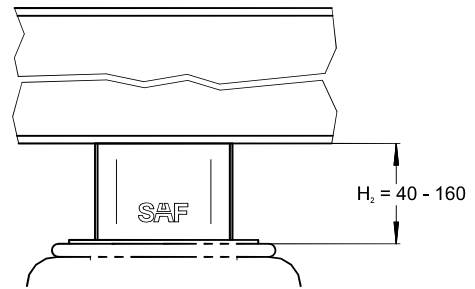



## Installation of hanger brackets „screw-on“

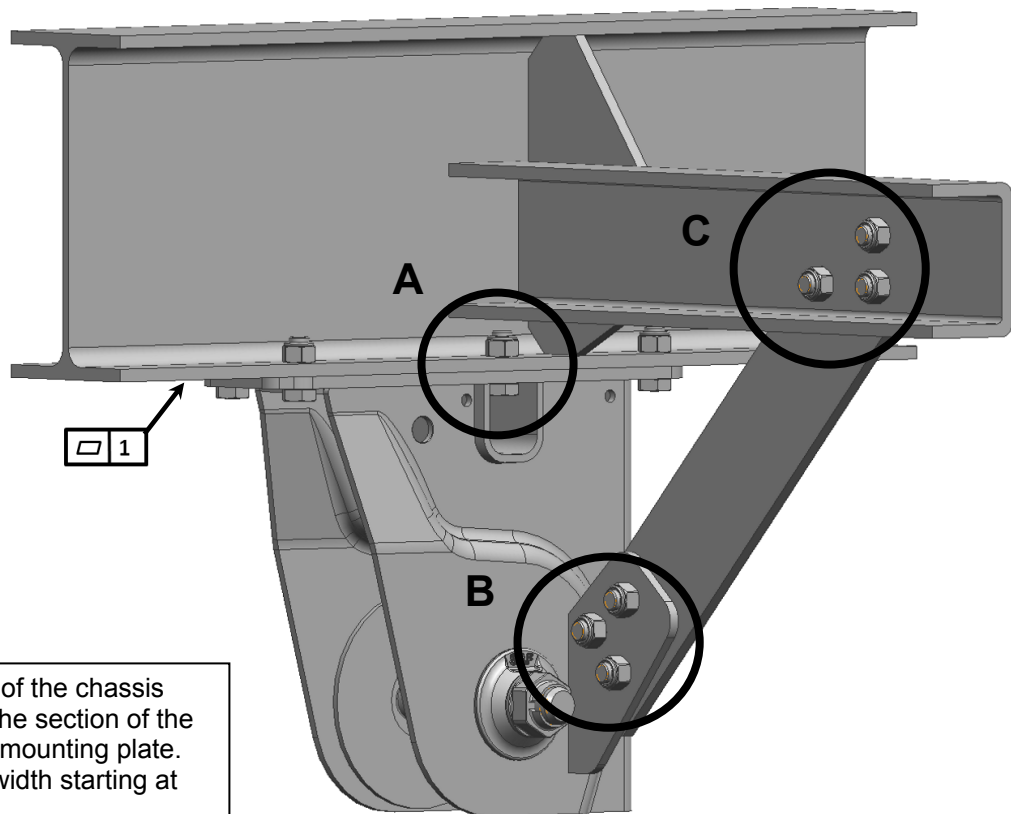

Max. evenness of the chassis beam 1 mm in the section of the hanger bracket mounting plate. Chassis beam width starting at 120 mm.

### Installation:

- 1) Install the hanger bracket with at least 5 screws M16, 10.9, **230 – 250 Nm** on the chassis. Only the middle screw towards axle centre can fail (Pos. A).
- 2) Pre-assemble the lateral brace as appropriate with 3 screws M16, 10.9 on the hanger bracket (Pos. B) and chassis (Pos. C) – do not tight these yet.  
hole in cross member  $\varnothing$  16mm  
hole in brace  $\varnothing$  18mm
- 3) Adjustment of track and mounting the pivot bolt according to SAF installation recommendation, see [page 91](#).
- 4) Tighten the lateral brace connections (Pos. B und C ) on the hanger bracket and chassis with maximum allowed torque.

Lateral brace and bolted connections are not SAF delivery volume.

Attachment faces for bolting connection parts:

- coat thickness when painting max. **30  $\mu$ m**
- coat thickness when galvanizing max. **100  $\mu$ m**

The top plate with the verified hole pattern as the lateral position and hole pattern of the lateral brace are the same for all [mentioned hanger brackets](#).

## Tightening torques for trailing arm – shock absorber - air bag

The maximum coat thickness of any primer or paint must not exceed **45 µm** on any contact surface of the suspension arm and shock absorber fixing!

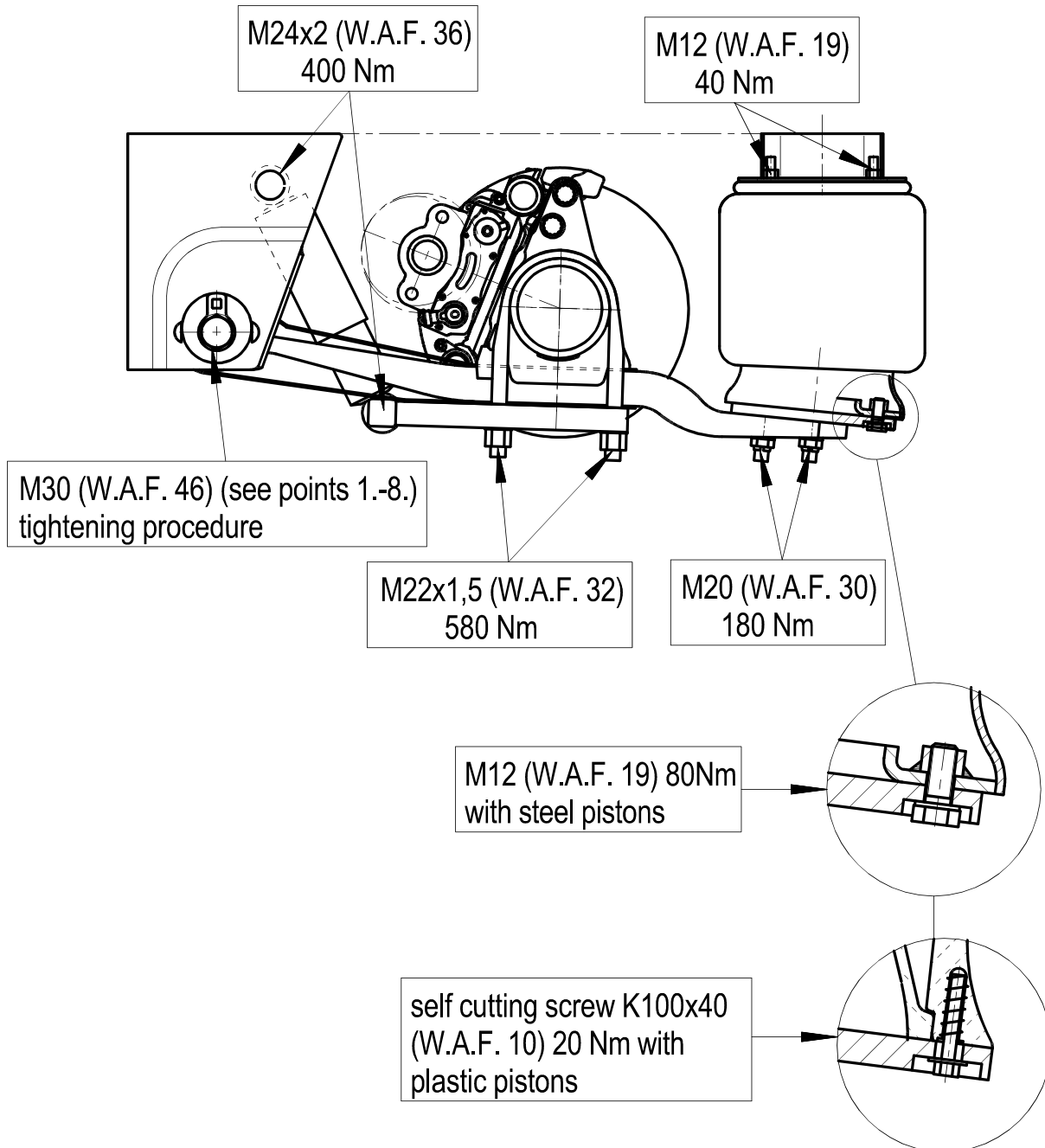

**Attention!**

- Threads are not to be oiled or greased!
- Pivot bolt mounting for hanger bracket „steel“ maintenance free.
- Pivot bolt mounting for hanger bracket „aluminium“ to be checked after 500 km, further checks every 6.000 km. Inspection torque 1200 Nm.

## Tightening instructions for adjustable pivot bolt

Attention: always within the specified ride height range!  
No paint residues between eccentric washer and hanger bracket!

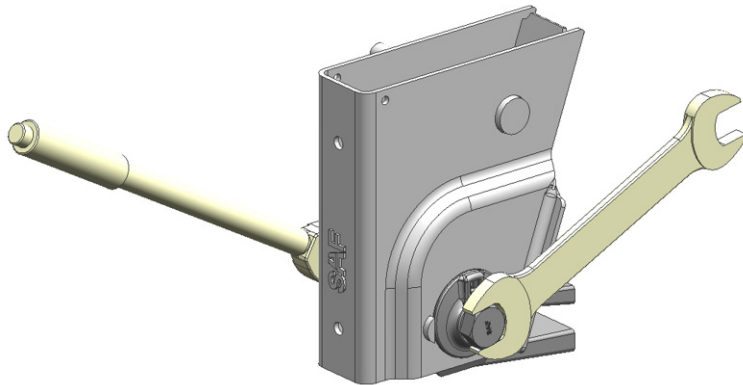

Bolt head always on the eccentric washer side

Pre tightening **400 Nm**  
Use torque wrench

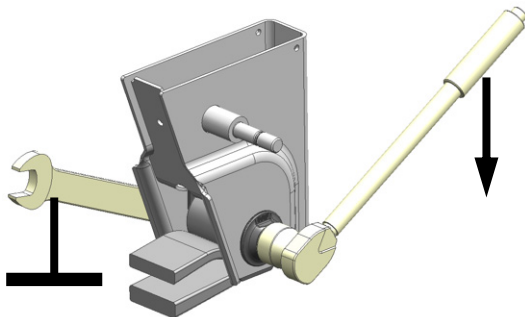

Marking for angle tightening

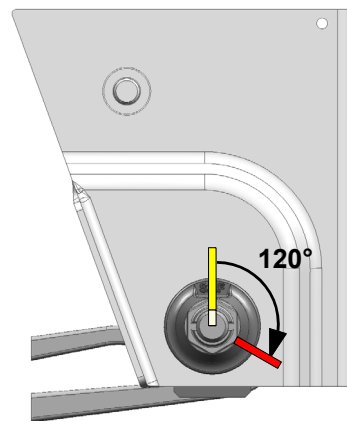

Angle tightening **120°**  
Use impact wrench or extend lever to 2,5 m.

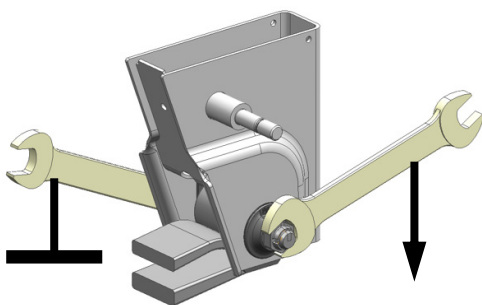

Visual inspection

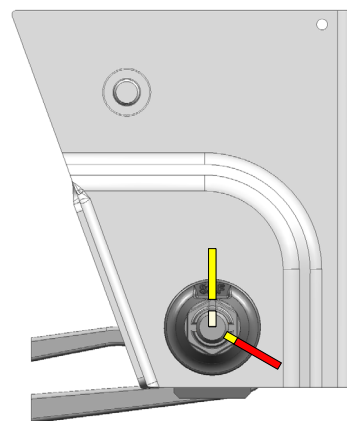

**Wheel fixing – Single 22,5“, drum brake (code 58)**

Single tyre with offset 0 mm  
 Wheel stud 1 303 1074 14 with stud length 85,5 mm  
 Wheel nut 4 247 3012 01

**STEEL WHEELS**  
ET=0

CENTERING RINGS -SEE POS 1  
 PART NO.: 1 095 1040 01  
 ABSOLUTELY NECESSARY FOR  
 WHEELS WITH BOLT CENTERING  
 MOUNTING: 2 RINGS PER  
 HUB IN OPPOSITION

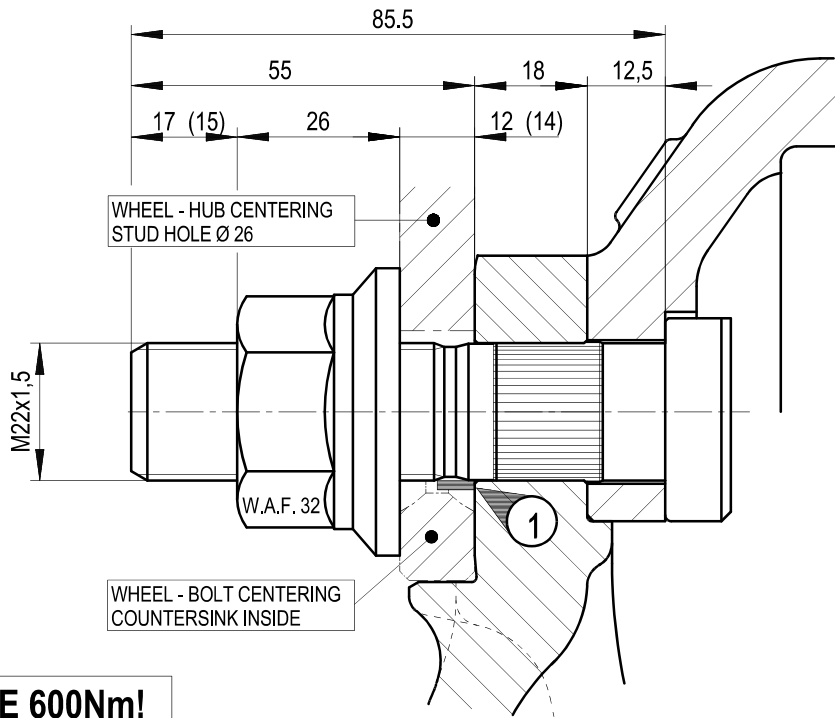

**TIGHTENING TORQUE 600Nm!**

**ALUMINIUM WHEELS**  
ET=0  
 STUD HOLE  $\varnothing 26$  mm  
 THICKNESS max. 26 mm

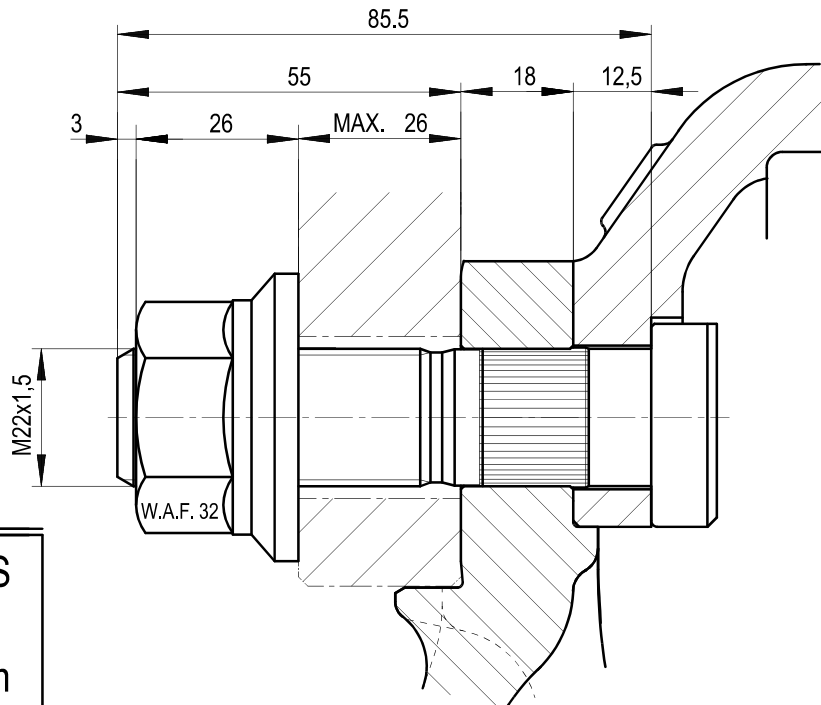

### Brake chamber bracket

Observe the installation instructions of the brake chamber manufacturer! A major factor for the functionality is the compliance with the specified tightening torque and its regular checking.

#### Example design with SNK 420

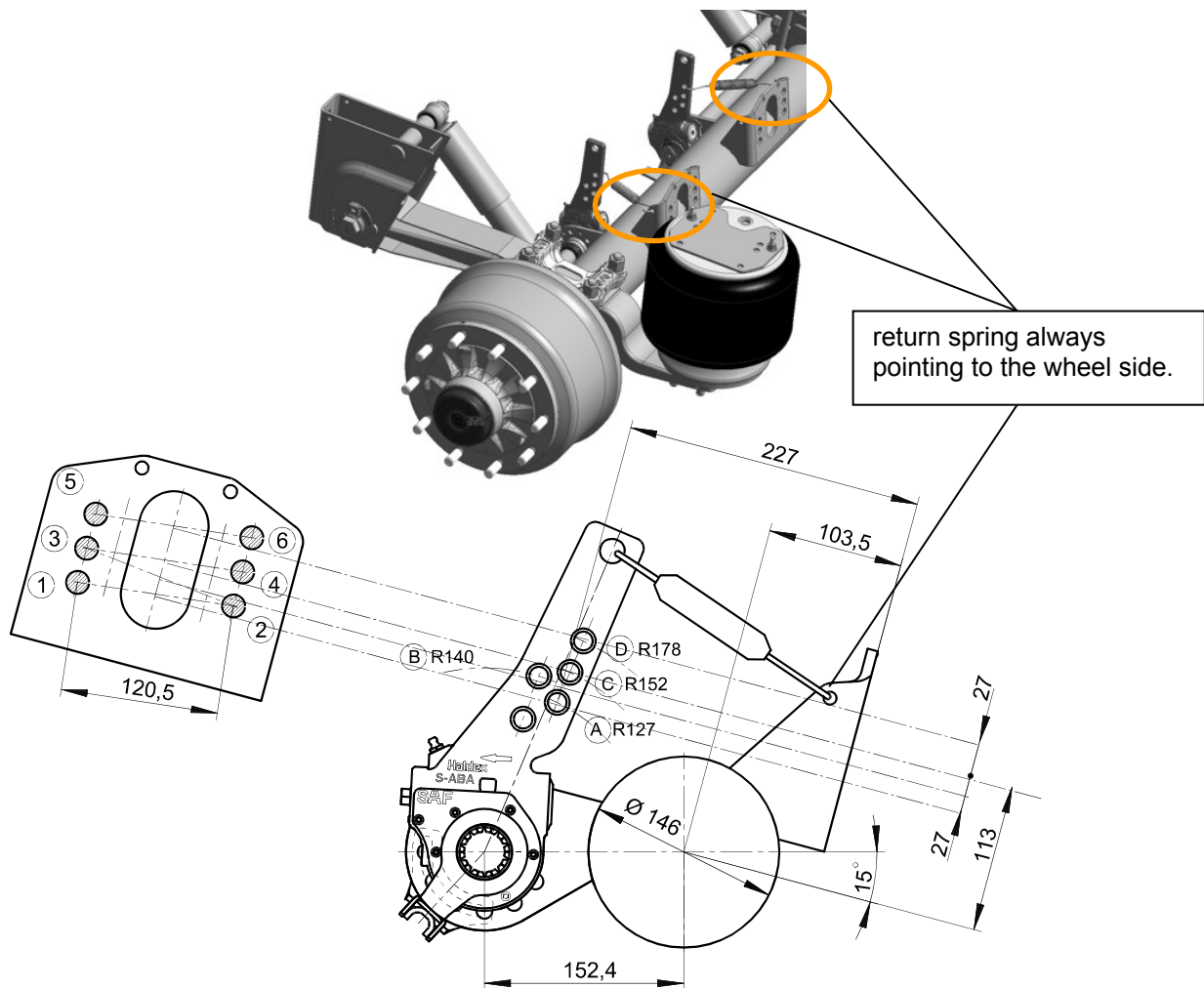

lever length of slack adjuster	code	brake chamber mounting position on the bracket
178 mm	D	5 – 6
152 mm	C	3 – 4
140 mm	B	2 – 3
127 mm	A	1 – 2

Brake chamber positions on the bracket are valid for manual and automatic slack adjusters!

## Overview SAF-HOLLAND brake chamber for axles with disc brake

The brake chambers can be combined with all SAF-HOLLAND axle versions with disc brake.

The brake chambers in overview:

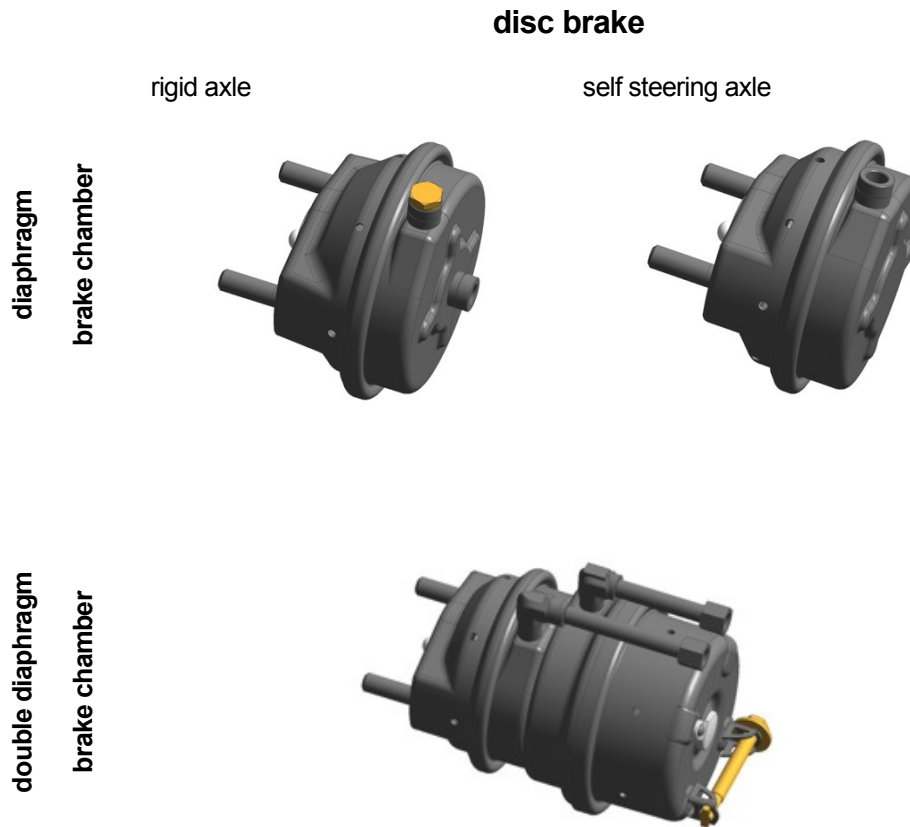

For axles with disc brake 22,5" and 19,5"

The versions in the table are available in both OEM and spare parts:

model	size	part number <sup>1)</sup> brake chamber	
		MODUL	
		rigid axle	self steering axle
diaphragm brake chamber	16"	3 454 1065 60	3 454 1081 60
	18"	3 454 1066 60	-
	20"	3 454 1067 60	3 454 1082 60
	22"	3 454 1068 60	-
	24"	3 454 1069 60	-
double diaphragm brake chamber	16"/24"	3 454 1077 64	-
	16"/30"	3 454 1096 64	
	18"/24"	3 454 1074 64	
	20"/24"	3 454 1079 64	
	20"/30"	3 454 1097 64	

<sup>1)</sup> partnumbers include the 2 fixing nuts

Brake chambers for axles with drum brake on request.

### Type identification for SAF-HOLLAND brake chambers

Letters are marked with "X", numbers with "0"  
 Example:

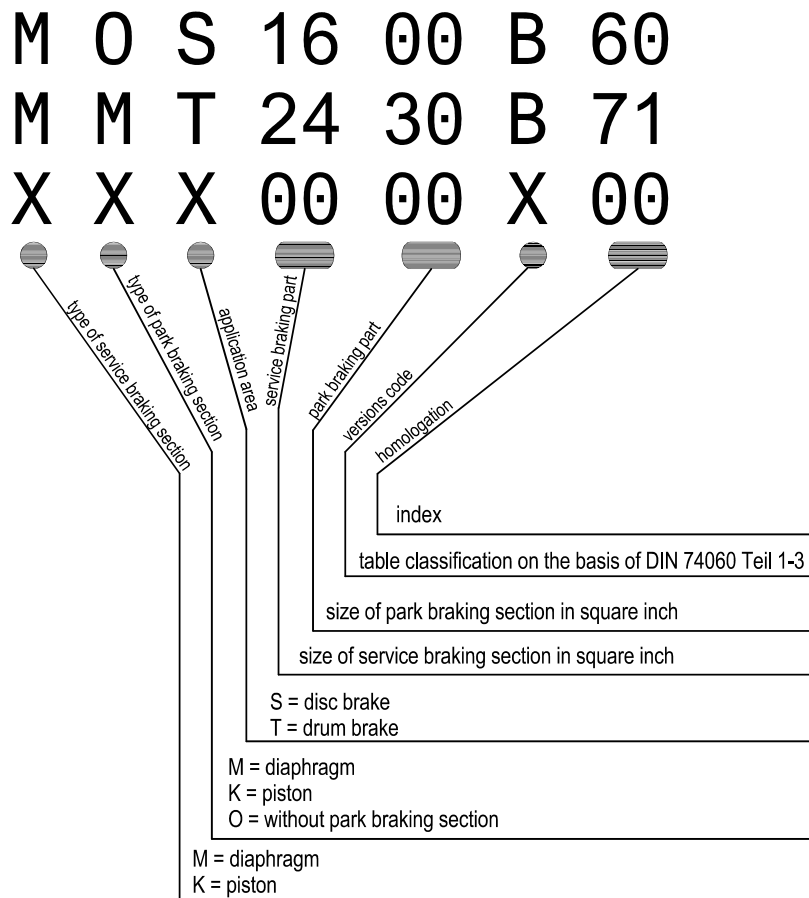

### Technical data

For axles with disc brake 22,5" and 19,5"

Model	size	type	test report	max. stroke S <sub>max</sub> [mm]	service brake: force [N] at 6,5 bar	parking brake: force [N] at 30 mm stroke
diaphragm brake chamber	16"	MOS1600B60	BC 0060.0	64	6590	-
	18"	MOS1800B60	BC 0061.0	64	6960	-
	20"	MOS2000B60	BC 0062.0	65	7564	-
	22"	MOS2200B60	BC 0063.0	65	8055	-
	24"	MOS2400B60	BC 0064.0	65	9374	-
double diaphragm brake chamber	16"/24"	MMS1624B60	BC 0044.0	63	6452	6160
	16"/30"	MMS1630B60	BC 0092.0	64	6590	7605
	18"/24"	MMS1824B60	BC 0045.0	63	6960	5911
	20"/24"	MMS2024B60	BC 0046.0	63	7564	6160
	20"/30"	MMS2030B60	BC 0093.0	65	7564	7605

Further technical data can be found on the referenced test reports or can be provided by SAF-HOLLAND (<http://testreport.safholland.de>). Brake calculations with these brake chambers can be provided by the brake system manufactures WABCO, KNORR and HALDEX. The new test reports are in accordance with ECE R13 and will require an update of the trailer type approval. Please notice that due to the new test procedure the output force characteristics of the brake chambers have changed.

## Installation instruction for brake chambers at axles with disc brake

For axles with disc brake 19,5" and 22,5"

### U – serie

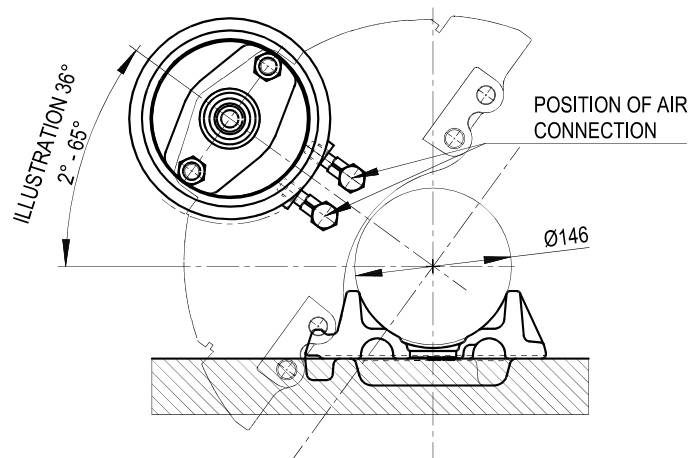

### M – serie

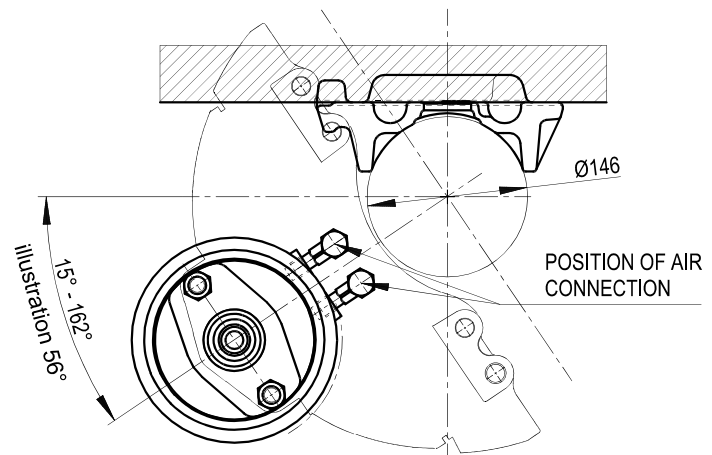

Tightening torque for brake chamber fixing to brake calliper: **210 Nm**

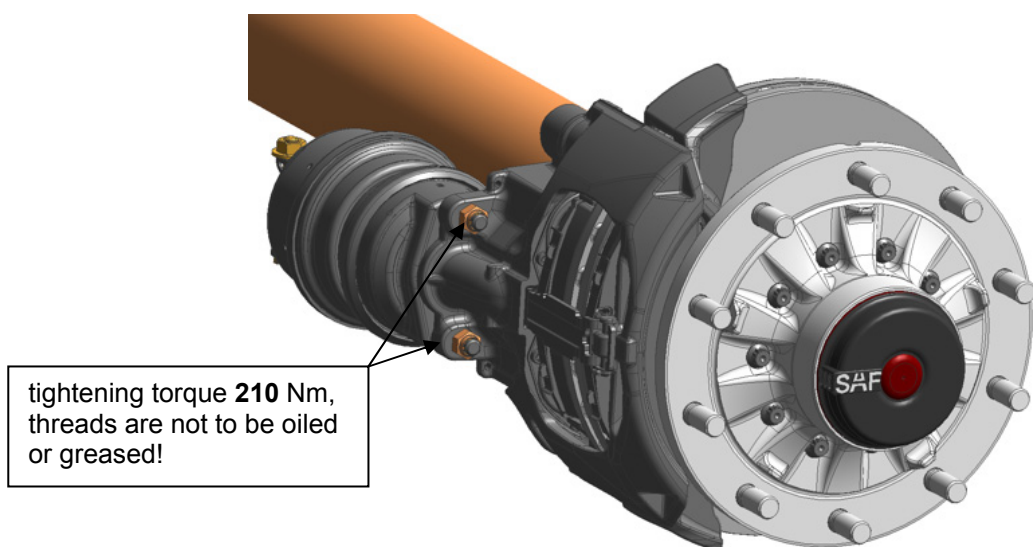



## Self-steering axle with pneumatic steering stabilising

### Steering mechanism

In the case of self-steering axle with pneumatic steering stabilising, the steering mechanism comprises:

- two pivot mounted steering knuckles (1)
- a steering tie rod (2)
- a reverse lock (3)
- a steering damper (4)
- two stabilising pneumatic cylinders with push rods (5)

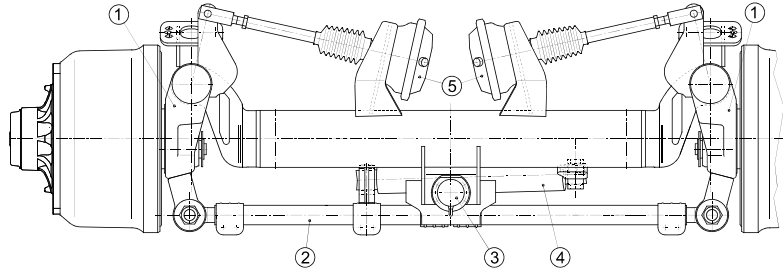

### Functional description

Side forces occur in the tyre contact areas when vehicles drive round bends or overtake other vehicles. On account of the offset between the steering knuckle bearings to the axle centre of 140 mm, these side forces (left and right) produce a steering torque that acts on the steering knuckles and forces them into an angled position. This angled position is the so-called axle steering angle. The steering tie rod is responsible for the synchronous turning movement between the left and right steering knuckles.

The stabilising cylinders are connected on one side with the axle beam and on the other side over a steering arm with the steering knuckle. The stabilising cylinders are under normal straight drive fully extended and are under load depending pressure (by the connection with the air bag) without force on the steering arms. When cornering (side force) the push rod of the stabilising chamber nearest to the inside tyre is pressed to the inside against the cylinder force. The telescopic push rod of the other stabilising cylinder is pulled out pressure less.

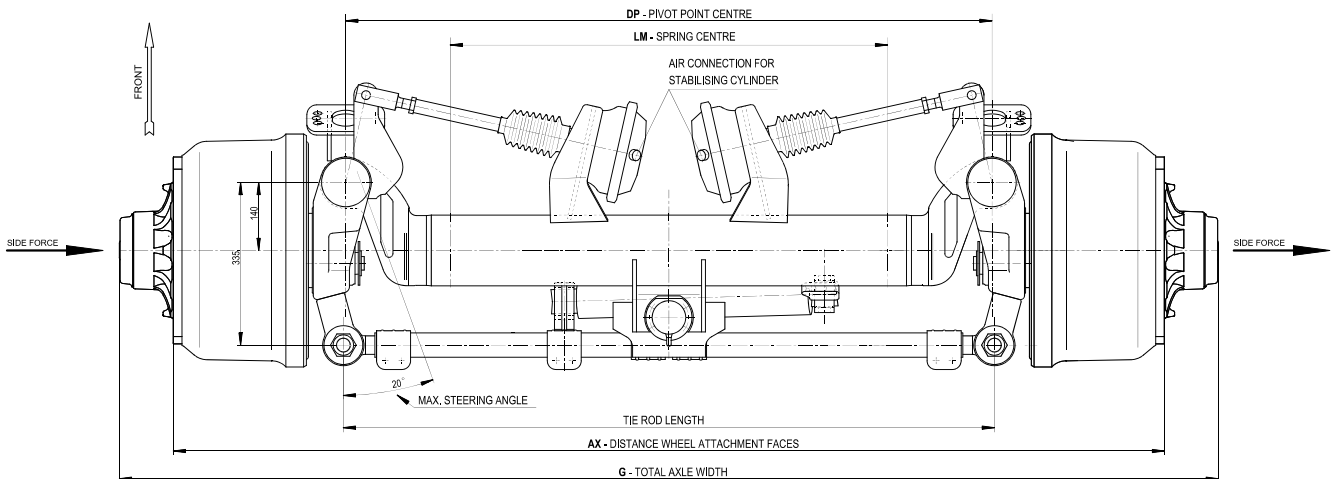

As the side forces decrease, the force in the stabilising cylinder increases in comparison with the side forces and forces the tyres and/ or steering knuckles back into the straight position. The steering damper supports a sturdy and flutter-free drive.

When adjusting, the stabilising pressure needs to be minimum 2,0 bar.

To make reversing possible with a self-steering axle, it has to be set rigid. This is done electro-pneumatically through the reversing lock, the task of which is to prevent the steering tie rod moving and to block it in the central position (driving straight on) by the spring-type cylinder.

## Self-steering axle with stabilising damper

### Steering mechanism

In the case of self-steering axle with stabilising damper, the steering mechanism comprises:

- two pivot-mounted steering knuckles (1)
- a steering tie rod (2)
- a reversing lock (3)
- a stabilising damper (4)

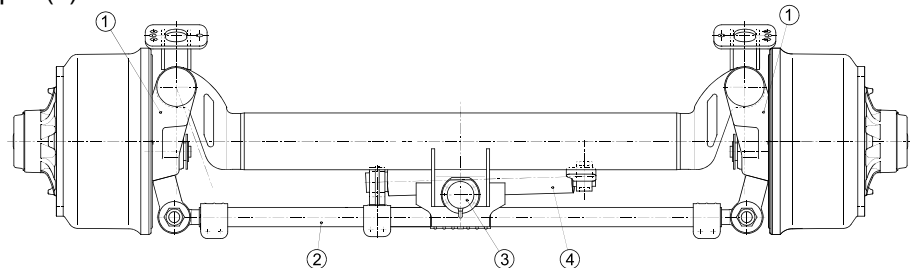

### Functional description

Side forces occur in the tyre contact areas when vehicles drive round bends or overtake other vehicles. On account of the offset between the steering knuckle bearings to the axle centre of 140 mm, these side forces (left and right) produce a steering torque that acts on the steering knuckles and forces them into an angled position. This angled position is the so-called axle steering angle. The steering tie rod is responsible for the synchronous turning movement between the left and right steering knuckles.

The stabilisation damper is suspended on the axle body on one side and on the steering tie rod on the other. This is either pressed (shortened) or pulled (lengthened) depending on the angle of rotation of the steering knuckles. The special design of this SAF stabilisation dampers means that its internal spiral spring is always compressed during both movements.

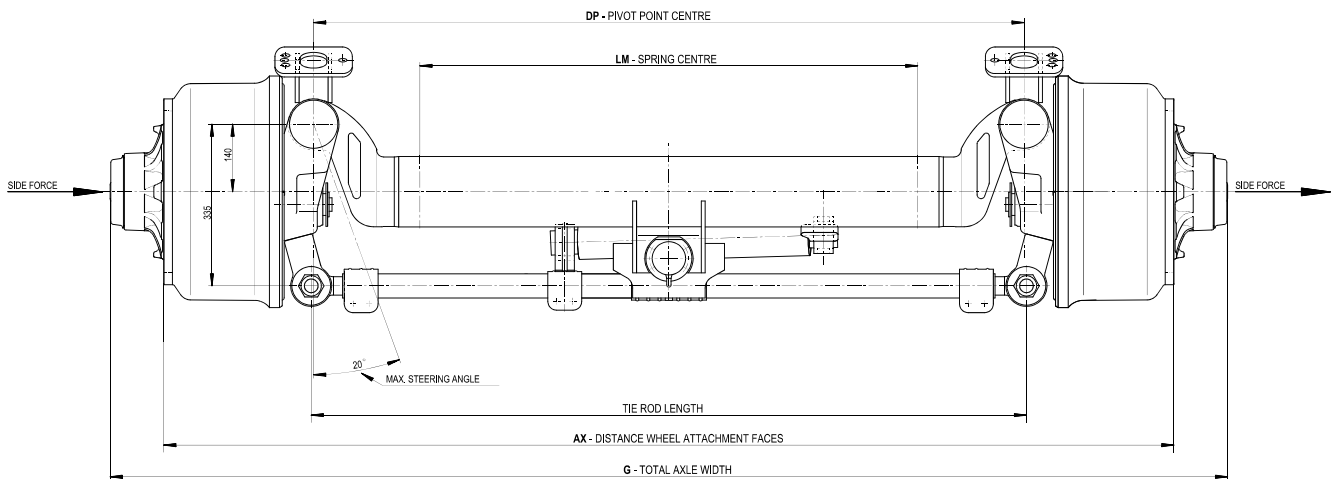

As the side forces decrease, the spring force increases in comparison with the side forces, and forces the tyres and/or steering knuckles back into the straight position. The spiral spring, supported by the damper properties, is also the reason for a sturdy and flutter-free straight drive.

To make reversing possible with a self-steering axle, it has to be set rigid. This is done electro-pneumatically through the reversing lock, the task of which is to prevent the steering tie rod moving and to block it in the central position (driving straight on) by the spring-type cylinder.

**Caster**

Installed in a suspension system, the caster (distance steering bolt centre lengthened to the ground to the centre of the tyre contact area) may vary in vehicle setting between 130 mm (steering pin tilted forwards) and 170 mm (steering pin tilted backwards). In contrast to leaf spring suspension, the caster can be influenced in the case of air suspension by the ride height setting.

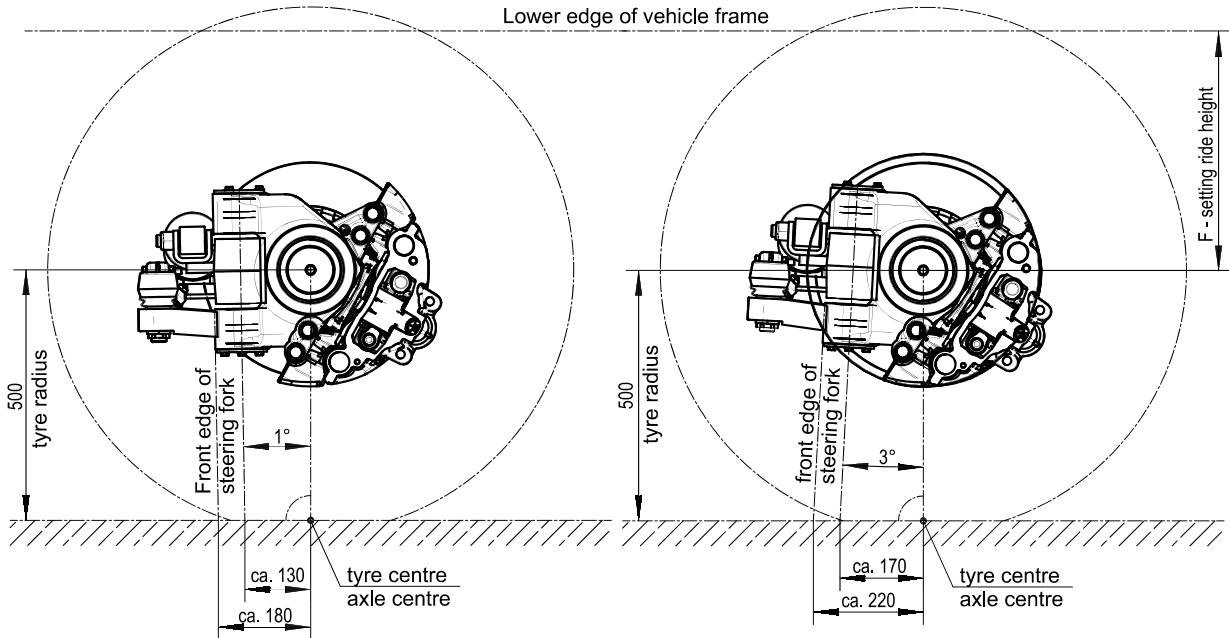

**Steering angle**

With SAF self-steering axles, the steering angle is limited to 20° on account of the design. This can be reduced if required, depending on the track width and spring centre ratio. For this purpose, the adjusting screw on the steering knuckle should be screwed out according to the values in the following table and then countered by a locknut.

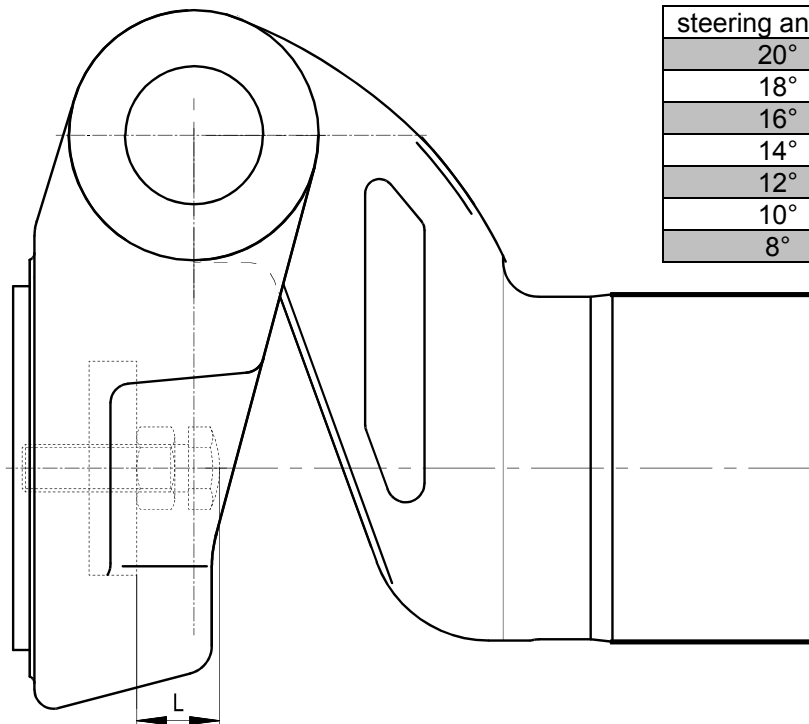

steering angle	bolt overhang „L“
20°	35 mm
18°	40 mm
16°	45 mm
14°	49 mm
12°	54 mm
10°	59 mm
8°	64 mm

## Adjustment of the air suspension ride height

### Air suspension valve

As standard, SAF-HOLLAND air suspension system require only one air suspension valve. The air suspension valve controls the air bag pressure in relation to the trailer load in order to maintain a constant ride height (F) in every load condition.

The air suspension valve is fastened to the trailer frame with screws and connected to the axle via the pivot joint (valve lever and adjustment pipe). On tri-axle trailers, the system is generally connected to the middle axle (normally in the middle of the axle), and on twin-axle trailers to the rear axle. In special cases (e.g. large trailer tilt angle), the air suspension valve can be installed on the rear axle.

For trailers with axle lifting system, the axle to which the system is connected depends on the axle to be lifted.

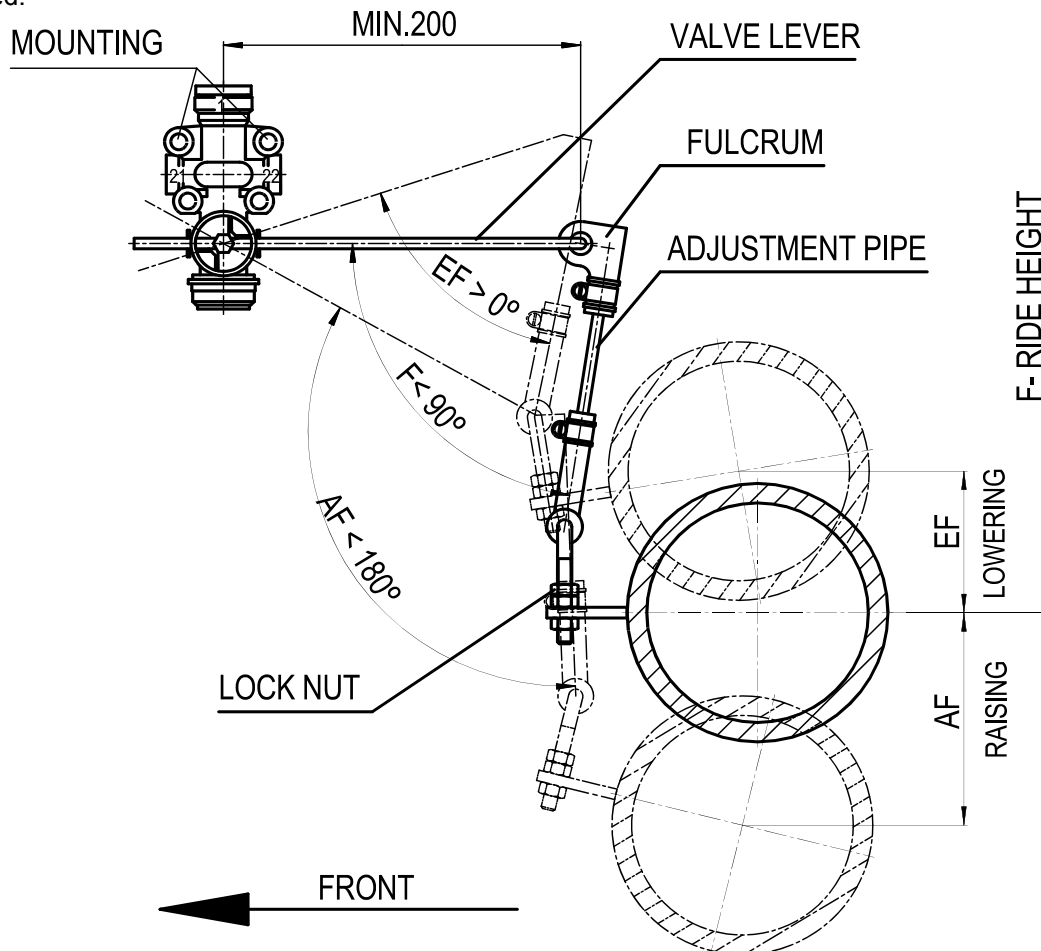

### Installation

The valve lever should be at least 200 mm long and is horizontal when the trailer is in the driving position. As a function check, move the lever down slightly. Air must now escape via the venting cap into the atmosphere. If air flows into the air bags when the lever is pushed down, the valve lever has to be turned through 180°. For this the valve lever has to be disconnected. The ride height is set by adjusting the adjustment pipe in the fulcrums and by turning the lock nuts. The adjustment must be carried out with the trailer standing on level ground. It can be carried out with the trailer either empty or loaded.

### Note

For a final check, the air suspension system should be lowered to the suspension stop or raised to the limit (shock absorbers, stop ropes, air bag length). During this process, the specified angle between valve lever and adjustment pipe must not be exceeded in order that the valve lever does not move in the wrong direction.

## Ride heights

Adjust the ride height of the air suspension to the permissible range indicated in the corresponding SAF-HOLLAND documents

With single axles, a minimum lowering of **60** mm is allowed.  
With multiple axles, a minimum lowering of **70** mm is allowed.

Exception:

For multi-axle trailers with lift axles, the minimum lowering at the lift axle should not be less than **100** mm in order to ensure an adequate ground clearance

## Semi-trailer tilt angle

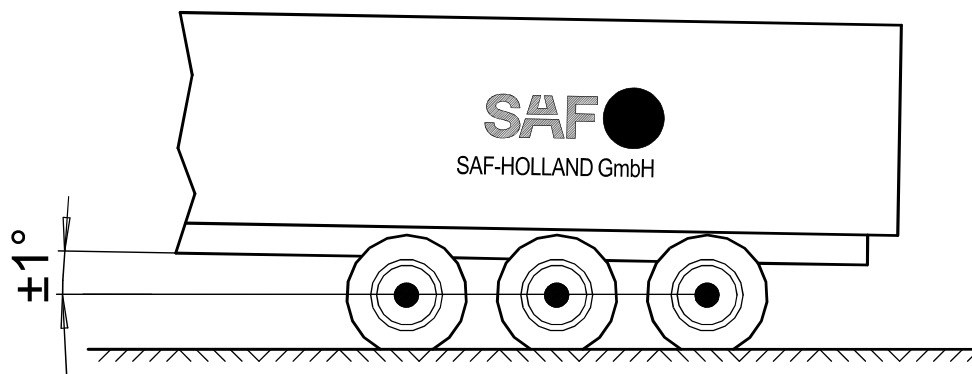

The maximum tilt angle of the semi-trailer can not be more than  $\pm 1^\circ$  or 20 mm/m.

## Axle alignment

### General

In order to compensate the production tolerances, an axle alignment and, if necessary, an adjustment should be carried out. The maximum permissible deviations (tolerances) of the alignment values are specified by the tyre manufacturer.

The maximum possible wheelbase correction per axle is  $\pm 6$  mm, see [page 62](#)

### Basic condition

The axle alignment must be done in unladen situation. With air suspension the trailer has to be adjusted in the right ride height.

### Conventional adjustment:

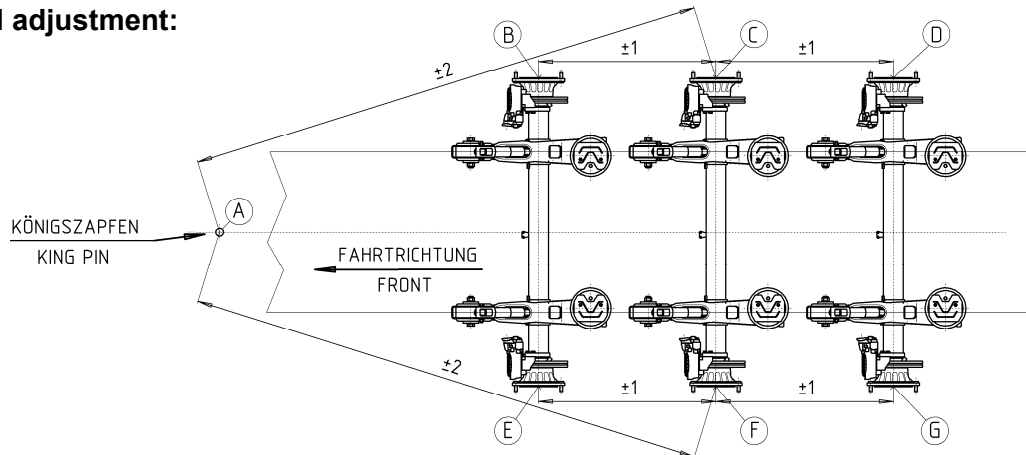

### Procedure:

Determine the lengths of the diagonals **A - C** and **A - F** for the middle axle (reference axle) by comparison measurements, observing the tolerances ( $\pm 2,0$  mm).

Check the wheelbases **B - C** and **E - F** for the front axle and **C - D** and **F - G** for the rear axle and correct, if necessary, observing the tolerances ( $\pm 1,0$  mm).

### Optical adjustment:

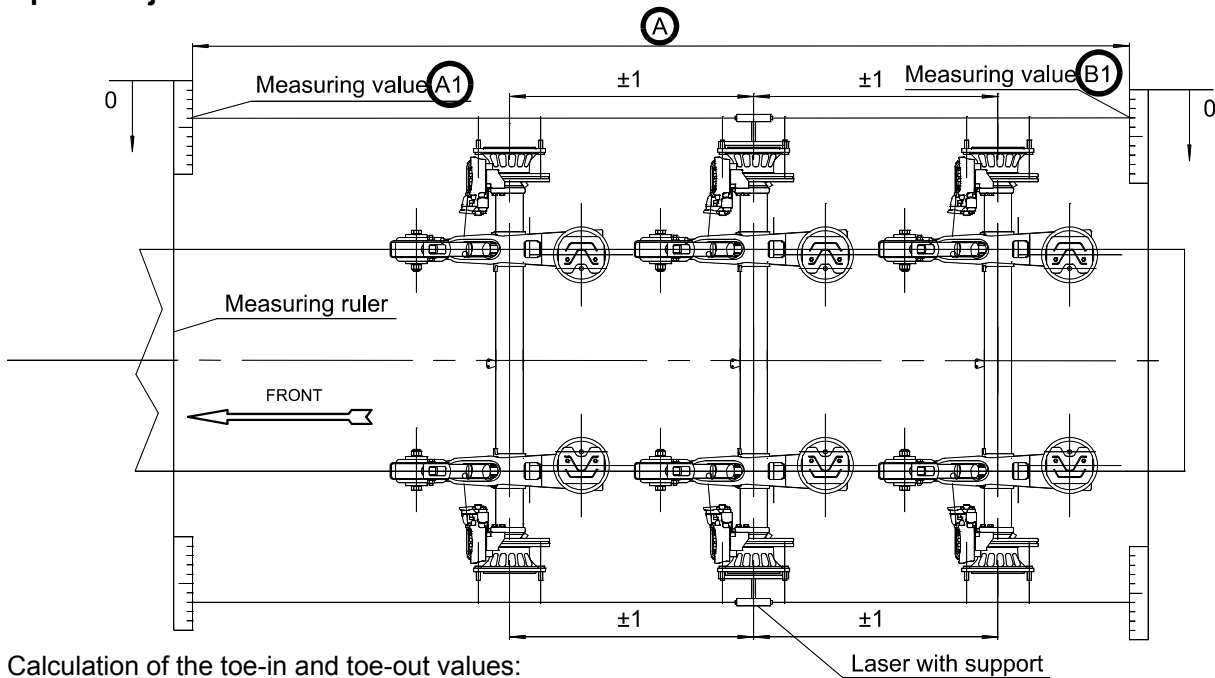

Calculation of the toe-in and toe-out values:

$$\frac{A1(\text{mm}) - B1(\text{mm})}{A(\text{m})} = C$$

C (positive value) = toe-in  
C (negative value) = toe-out

Observe the operating and setting instructions of the measuring system manufacturer.

**Positive Toe / toe-in :**

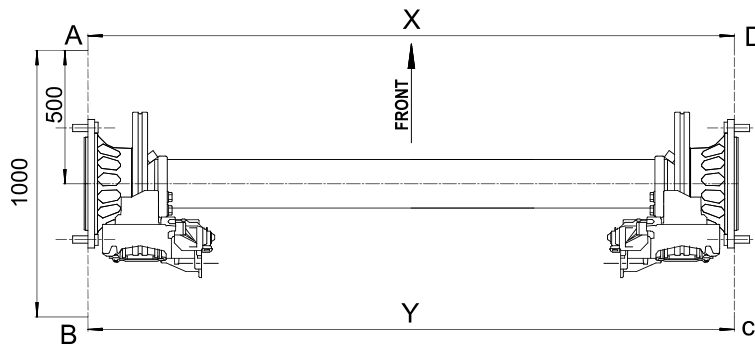

Rigid axle:

Toe-in: +0 to +12' = max. +3,5 mm/m (Example:  $Y - X = 0 + 3,5$  mm)

Self-steering axle:

Toe-in: +14 to +24' = min. +4 mm/m to max. +7 mm/m (Example:  $Y - X = 4$  mm to 7 mm)

The setting is carried out by lengthening or shortening the steering tie rod. After all the clamping clips have been loosened, the required dimension is set by turning steering tie rod. The tie-rod ends are not affected.

Distance „A“ must be the same, in consideration of the toe-in. Distance „B“ is 537 mm, for this use the locking device.

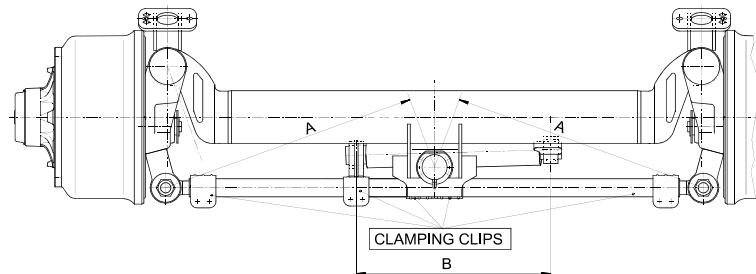

In case of a self-steering axle with pneumatic stabilising, the push rods of the stabilising cylinder must be free of play („C“) to be adjusted if needed. For this the pressure in the stabilising cylinder must be at a min. of 2 bar.

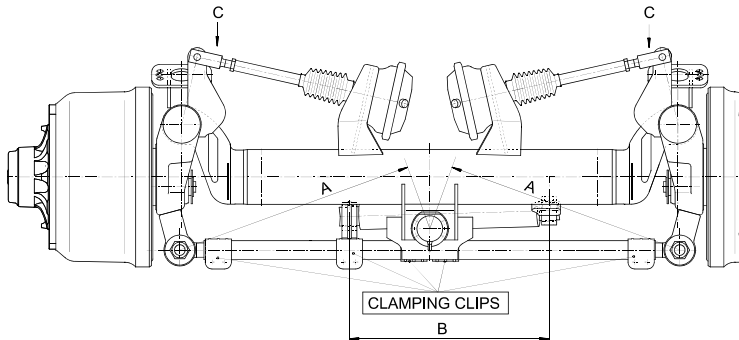

When adjusting the toe-in/ toe-out, the correct setting of the ride height needs to be observed (and the minimum pressure in the stabilising cylinders).

**Camber:**

The wheel camber ( $\alpha$ ) has been designed fixed and cannot be adjusted. For the unloaded axle, the value is  $\pm 12'$  positive camber (corresponds to 3,5 mm/m)

In order to avoid tyre wear, we recommend that an axle alignment is performed at regular intervals. We recommend the use of an optical measuring system for carrying out the axle alignment. For alignment, only the centres of the middle of the wheel cap or the middle of the axle stub end are of interest as reference points.

Possible causes of deviations in the axle alignment are:

- ✓ Loose U-bolt connection
- ✓ Wear of the pivot bush
- ✓ Deformation of the axle assembly components due to improper use

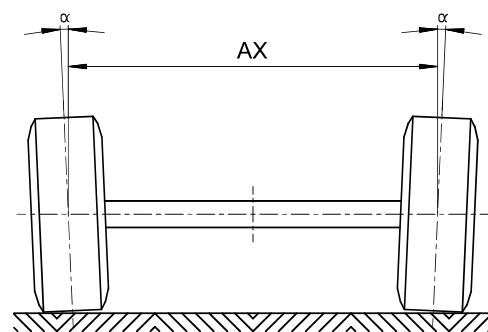



## Classification of exciter ring teeth

With the launch of the axle generation 06, SAF-HOLLAND standard supplies the exciter ring and sensor bracket preinstalled. The number of teeth is now dependent on the wheel mounting, tyre size installed and their dynamic rolling circumference have been taken into consideration.

axle generation SK						axle generation 06	
no. of teeth	axle version	tyre size	wheel fixing			axle version	no. of teeth
			bolt pitch circle	centre bore	no. of bolts		
80	SK RZ 9030	17,5"	225	175	10	Z9-3020	80
	SK RZ 11030					Z11-3020	
	SK RZ 12030					-	
90	SK RS/RZ 9037	19,5"	275	220	8	S/Z9-3718/20	90
	SK RS/RZ 11037					S/Z11-3720	
	SK RZ 12037					-	
	SK RS/RZ 9037					S/Z9-3718/20	
	SK RS/RZ 11037	S/Z11-3720					
	SK RS/RZ 9019	S/Z19-19					
	SK RS/RZ 11019	S/Z111-19					
100	SK RB 9019	19,5"/22,5"	335	280	10	BI9-19	100
	SK RB 9022	22,5"				BI9-22	
	SK RS/RZ 9022					S/Z19-22	
	SK RS/RZ 11222	S/Z111-22					
	SK RS/RZ 9042	S/Z9-4218					
	SK RS/RZ 11242	S/Z11-4220					
	SK RS/RZ 12242	-					

The exciter ring of steered axles (self-steering and power steered) has the same number of teeth as with the rigid axles. For example: the exciter ring of axle version S11-4220 has 90 teeth, so is also the exciter ring of the self-steering axle SL11-4220 and the steered axle SZL11-4220 with 90 teeth.

### Note:

On the SAF axle generation 06 (B-, S- and Z-serie) the position of the exciter ring is on the inside of the wheel hub, irrespective of the type of brake (disc or drum).



disc brake



drum brake



## Installation instruction ABS cable

### Axle with disc brake

Rod sensor (2) with clamping bush (1) pressed in completely (till exciter ring) by hand.

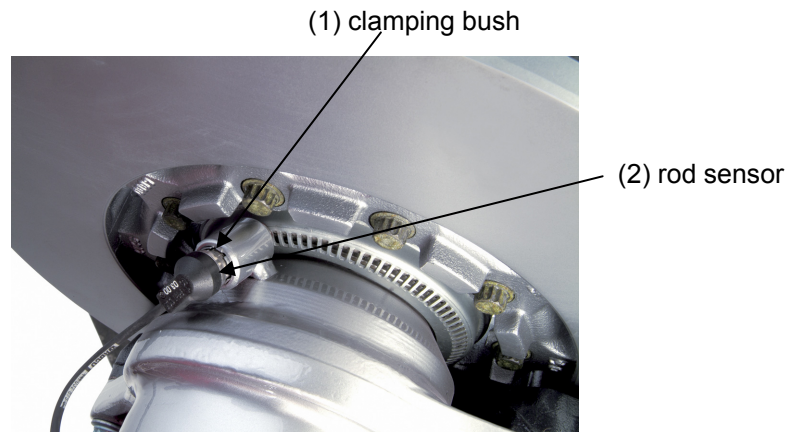

The fixation of the ABS cable on the supplied axle serves the transport security. The cable can not touch any adjacent, moving parts.

(3) cable strap

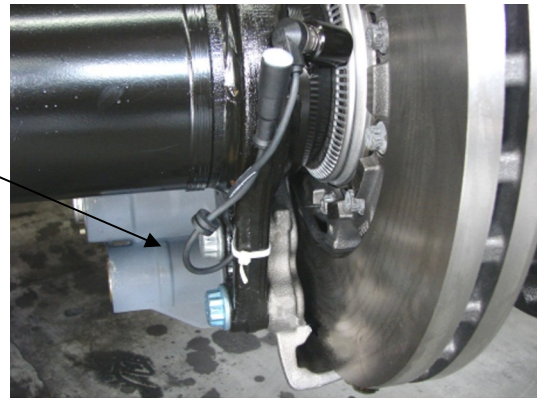

The sensor cable must not be laid taut or kinked!  
The correct installation is a responsibility of the trailer builder.

order no. for ABS group: (per axle 2x)			pos.:	per kit
	rigid axle:	self-steering axle:		
	3 029 0238 05	3 029 1002 00		
clamping bush	4 029 1071 00	4 029 1002 00	(1)	1x
rod sensor	4 029 1072 00	4 029 1013 00	(2)	1x
cable strap	4 194 2030 00	4 194 2031 00	(3)	1x

## Installation instruction ABS cable

### Axle with drum brake, axle generation 06

#### at SNK 300

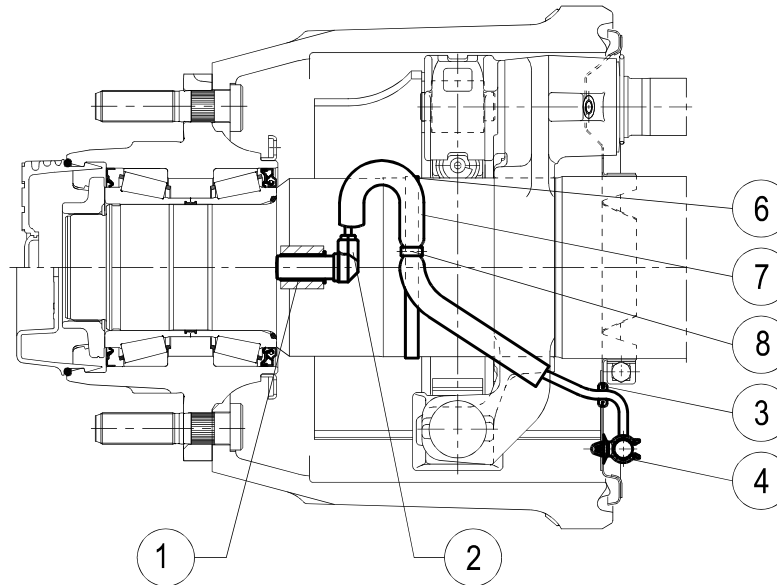

#### at SNK 420 and SNK 367

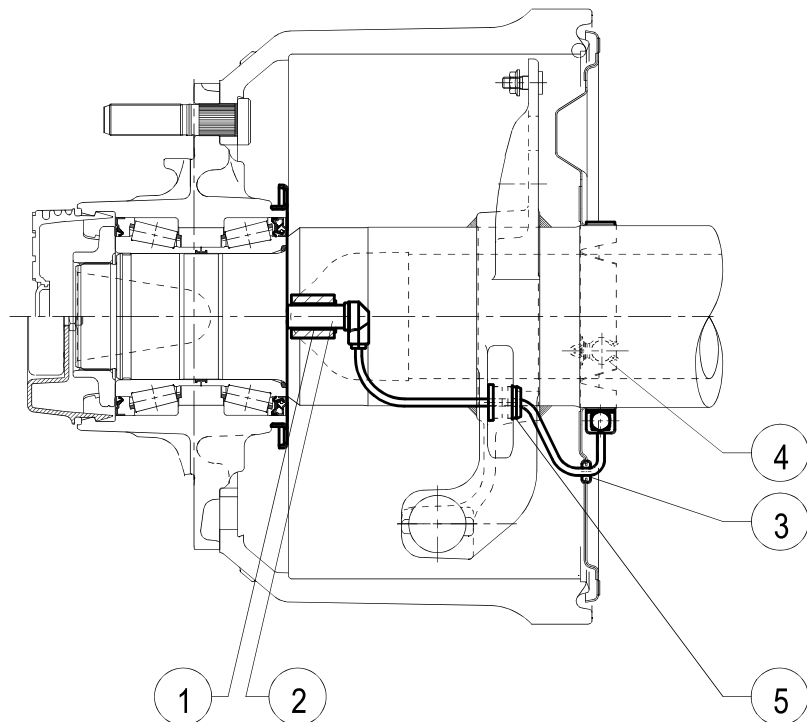

order no. for ABS group: (per axle 2x)		pos.:	pro kit
SNK 420 and SNK 367 3 029 0234 05	SNK 300 3 029 0236 05		
clamping bush	4 029 1013 00	(1)	1x
rod sensor	4 029 1002 00	(2)	1x
rubber grommet	4 177 3018 00	(3)	1x
cable clamp	4 189 0044 00	(4)	1x
plug	4 337 2028 00	(5)	1x
clamping clip	-	(6)	1x
protecting tube	-	(7)	1x
clamping ring	-	(8)	1x

### Installation instruction, connecting cable kit for pad wear sensing on WABCO calliper

BRAKE CALIPER

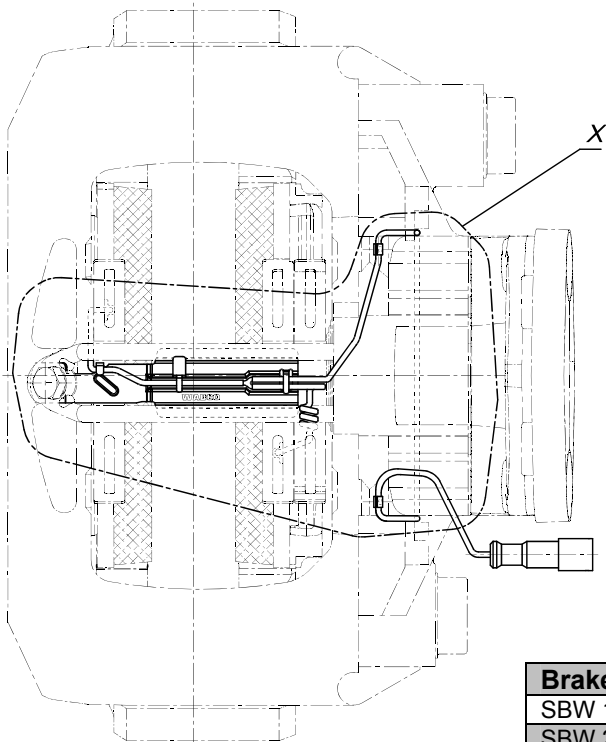

Note:  
1 connection cable kit per axle

Brake	Type	connecting cable kit
SBW 1937	PAN 19-1 / PAN 19-1+	3 424 2001 00
SBW 2243	PAN 22-1	3 424 2009 00

4 042 2001 00 (SBW 1937/2243)  
4x FIXING PARTS

DETAIL X

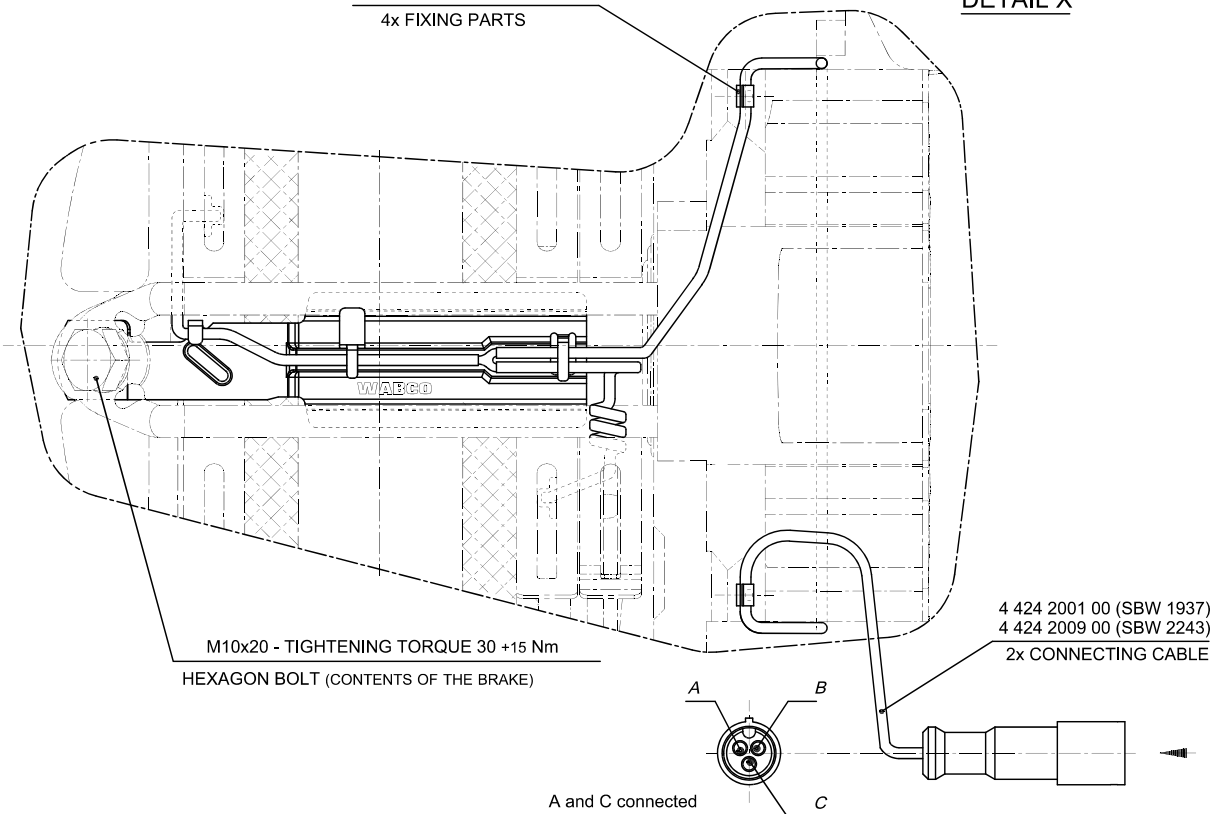

Amendments and errors excepted. XL-AS10004DM-en-DE Rev B © SAF-HOLLAND

# Installation instruction, connecting cable kit for pad wear sensing on KNORR calliper

BRAKE CALIPER

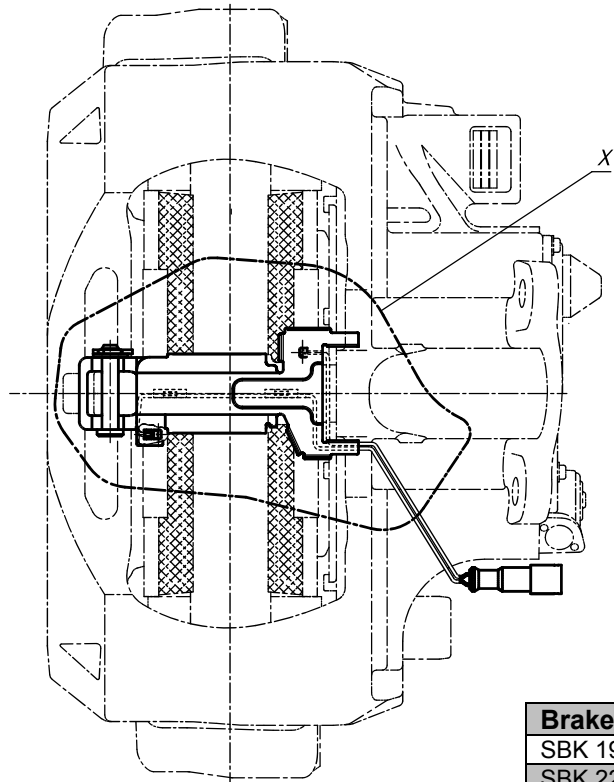

Note:  
1 connecting cable kit per axle

Brake	Typ	connecting cable kit
SBK 1937	SB6...(SN)	3 424 2008 00
SBK 2243	SB7...(SN)/ SB7...(SK)	

- 4 353 0034 00 (ONLY FOR SB7... / SB6...)  
2x SPLINT
- 4 424 2004 00 (ONLY FOR SB7... / SB6...)  
2x WASHER
- 4 051 0058 00 (ONLY FOR SB7... / SB6...)  
2x BOLT
- 4 073 0025 00 (ONLY FOR SB7...)
- 4 073 0026 00 (ONLY FOR SB6...)
- 2x LINING FIXING HOOP

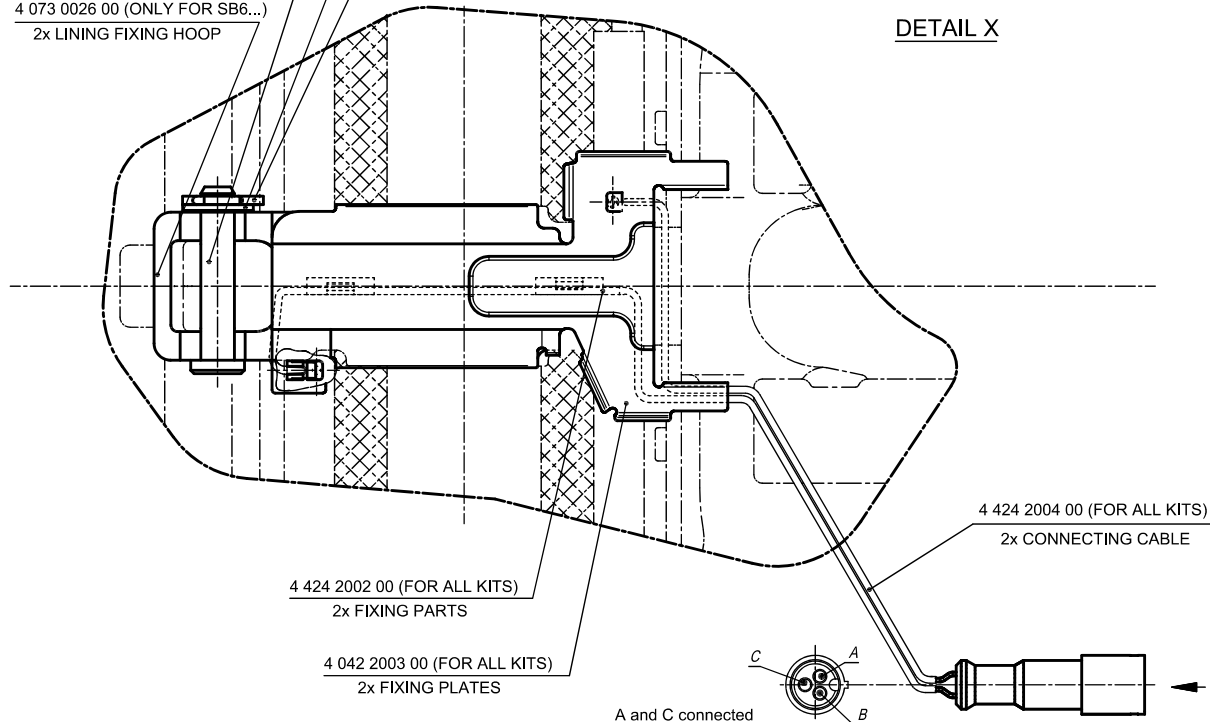

4 424 2002 00 (FOR ALL KITS)  
2x FIXING PARTS

4 042 2003 00 (FOR ALL KITS)  
2x FIXING PLATES

4 424 2004 00 (FOR ALL KITS)  
2x CONNECTING CABLE

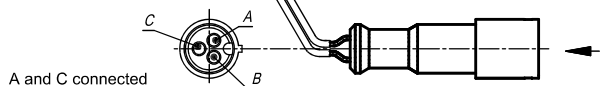

Amendments and errors excepted. XL-AS10004DM-en-DE Rev B © SAF-HOLLAND

## SAF-O-Meter

Designation:

Rolling circumference range:	SAF-O-Meter order no.:	Tyre example:
2360 – 2455 mm	4 388 0241 00	245/70R17,5" or 235/75R17,5"
2590 – 2690 mm	4 388 0264 00	265/70R19,5"
2655 – 2765 mm	4 388 0271 00	445/45R19,5"
2850 – 2970 mm	4 388 0291 00	425/55R19,5"
2980 – 3100 mm	4 388 0304 00	385/55R22,5"
3125 – 3250 mm	4 388 0319 00	11R22,5" or 295/80R22,5"
3185 – 3315 mm	4 388 0325 00	385/65R22,5"
3420 – 3560 mm	4 388 0349 00	425/65R22,5"

For example:

axle version: S9-4218  
 Tyre size: 385/65R22,5"  
 with rolling circumference  
 (E.T.R.T.O Norm): 3248 mm

- SAF-O-Meter 4 388 0325 00
- Radkappe 4 304 0103 01.

axle version: SK RZ 12037  
 tyre size: 285/70R19,5"  
 with rolling circumference  
 (E.T.R.T.O Norm): 2730 mm

- SAF-O-Meter 4 388 0271 00
- Schutzkappegr. 3 337 0041 01

## Installation

Please check before fitting whether you have received the right SAF-O-Meter suitable to your tyre size!

**axle generation 06, example:**  
**axle version S9-4218**



standard hubcap  
4 304 0102 00



hubcap for SAF-O-Meter  
4 304 0103 01

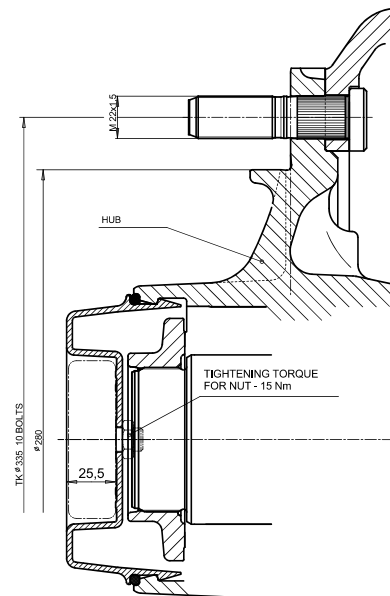

**axle generation SK, example:**  
**axle version**  
**SK RZ 12037**



hubcap



hubcap with protection cap group.  
3 337 0041 01 for SAF-O-Meter

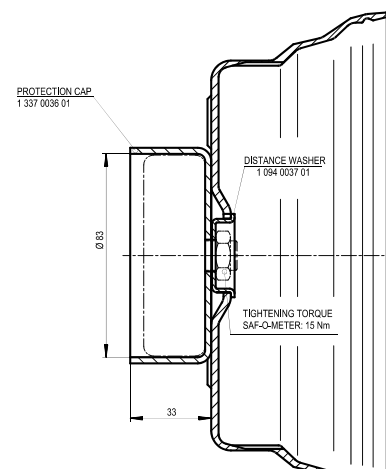

The sketches show, irrelevant of the axle types, how the SAF-O-Meter is fitted in the hub caps. It is not important on which side of the vehicle it is fitted, as the counter functions are independent of the direction of rotation.