

ELECTRO-HYDRAULIC STEERING SYSTEM FOR TRAILERS

VSE SMART STEERING

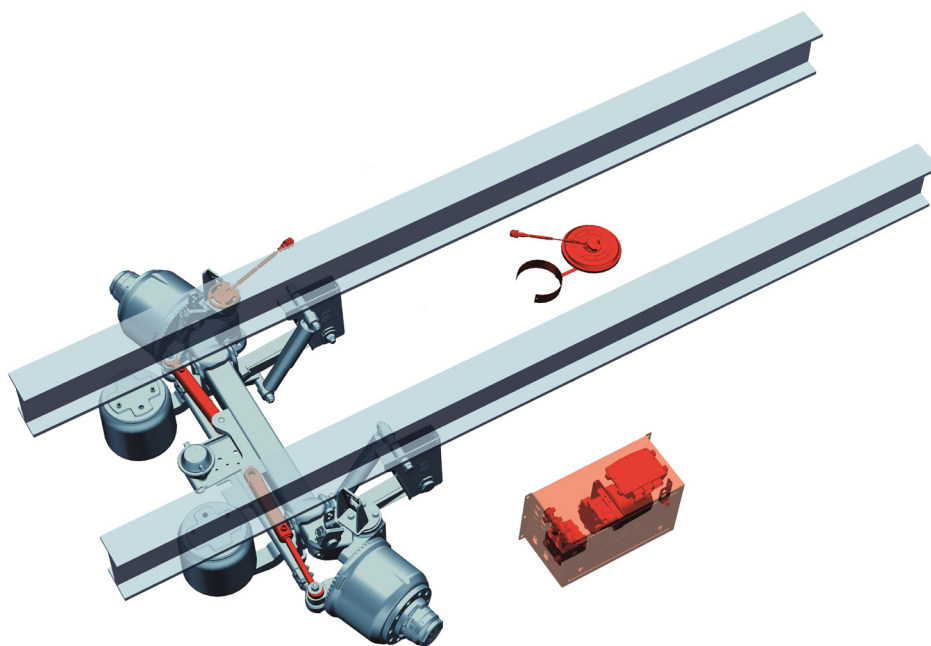

Weight	System locker dimensions L x W x H
40 kg	550 x 270 x 350 mm

SPECIFICATIONS

- System weight without axle 40 kg
- Suitable for one steering axle
- Temperature range -30 to +40 degrees Celsius
- Suitable for any axle
- Steering system active up to 25 km/h
- Can be retrofitted

APPLICATIONS

- For any type of trailer with a self steer axle