

ELECTRO-HYDRAULIC STEERING SYSTEM FOR TRAILERS

VSE SPECIAL STEERING

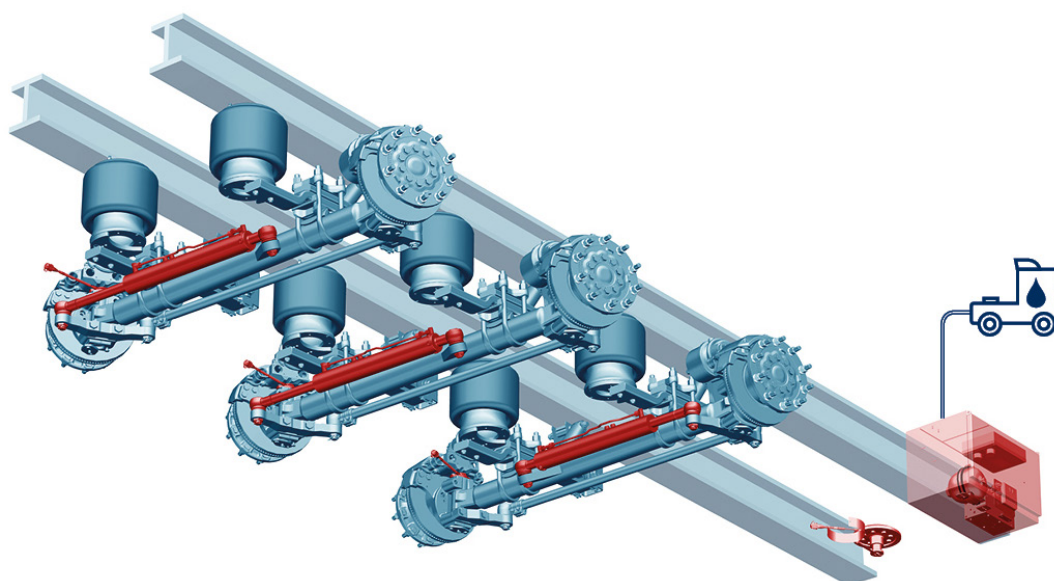

Type	Weight	System locker dimensions L x W x H
1M	80 kg	400 x 400 x 400 mm
2M	120 kg	600 x 400 x 400 mm
3M	190 kg	800 x 400 x 400 mm

SPECIFICATIONS

- Customized software
- Only with electric pump
- Manual control optional
- Stainless steel locker with electric pump, also possible with batteries
- Standard and custom lockers
- Suitable for any axle

APPLICATIONS

- Distribution
- Tank transport
- Construction
- Heavy transport
- Special transport