

ELECTRO-HYDRAULIC STEERING SYSTEM FOR TRAILERS

VSE ADVANCED STEERING

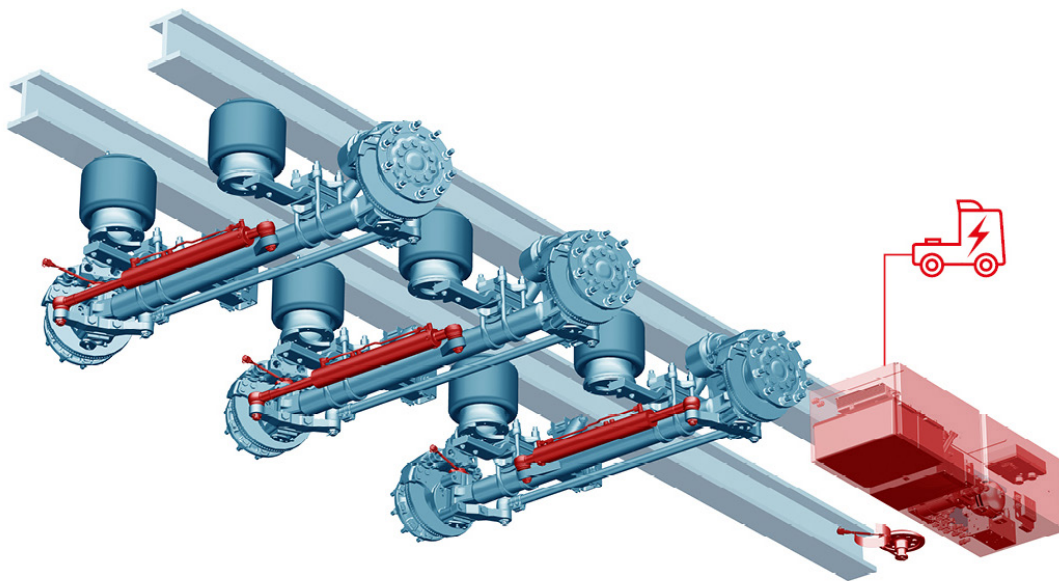

Type	Weight	System locker dimensions L x W x H
1E	160 kg	1.000 x 550 x 400 mm
2E	200 kg	1.000 x 550 x 400 mm
1EB	280 kg	1.250 x 550 x 400 mm
2EB	340 kg	1.500 x 550 x 400 mm
3EB	470 kg	2.000 x 550 x 400 mm

SPECIFICATIONS

- Customized software
- Only with electric pump
- Manual control optional
- Stainless steel locker with electric pump, also possible with batteries
- Standard and custom lockers
- Suitable for any axle

APPLICATIONS

- Distribution
- Tank transport
- Construction
- Heavy transport
- Special transport