

HD50F

Automatic couplings

The V.ORLANDI HD50F series is a 50 mm manual drawbar coupling, which is designed for steering drawbar trailers. This coupling series is homologated according to ECE R55 standard and it is easy to handle and can be maintained very fast and cost efficient.

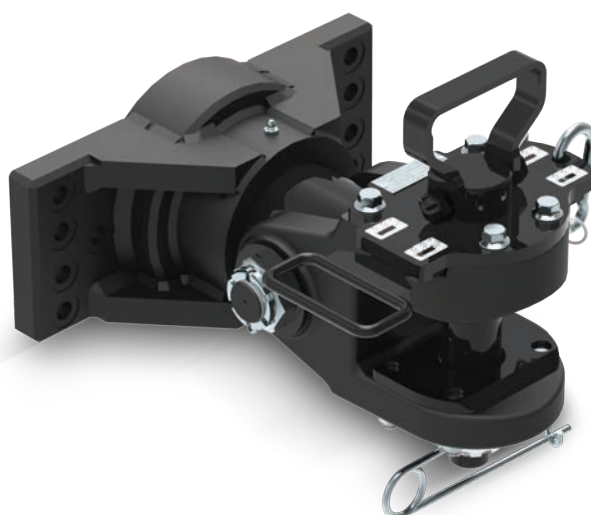

Technical data

Flange size	330 x 110 [mm]
D-Value	400 [kN]
Weight	71 [kg]
Homologation	ECE R55 (class S)
Drawbar eye standard	ECE R55 (class S); CUNA 438-55 (Cat VII)

Specs

- Heavy weight transport
- Oscillating coupling
- Special Fixed flange allows rotating of 360°
- ± 95° steering angle and ± 22° vertical oscillation
- High towing values
- Proved according to the latest ECE-R55

HD50F

Automatic couplings

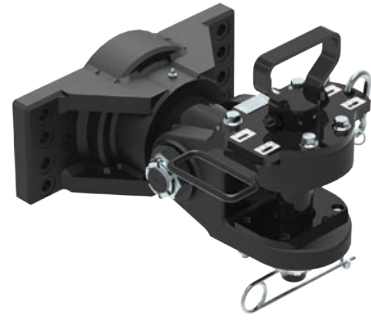

For drawbar eyes	Ø 50	ECE R55
------------------	----------------	---------

TECHNICAL DATA

Part number	Hole pattern [mm]	D-Value [kN]	Total trailer weight [t]	Weight [kg]	Homologation	
					Class	ECE R55
HD5F251	See figure "X"	400	250	72.5	S	E32 01-0022

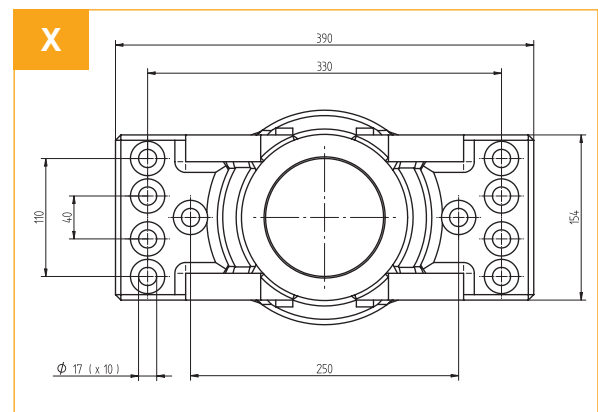
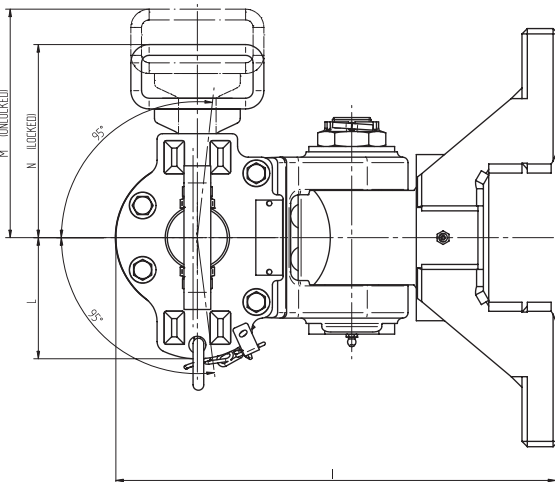
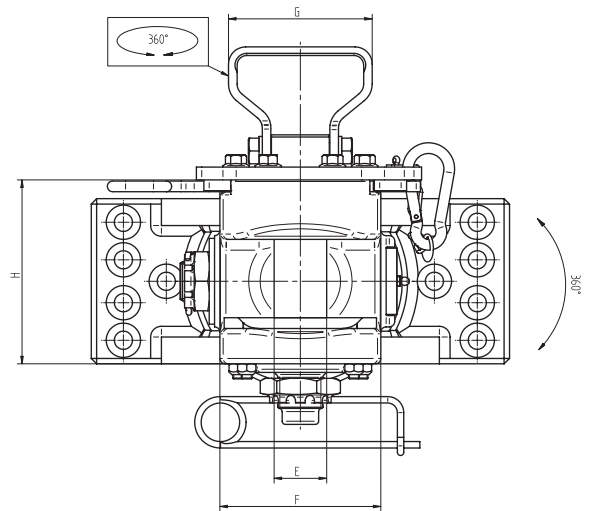
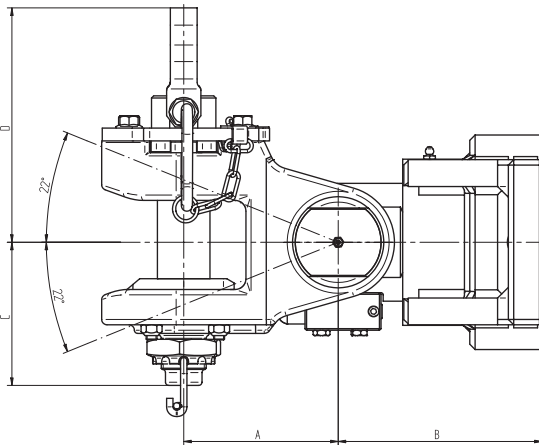

Part number	A [mm]	B [mm]	C [mm]	D [mm]	E [mm]	F [mm]	G [mm]	H [mm]	I [mm]	L [mm]	M [mm]	N [mm]
HD5F251	144	190	133.5	218.5	∅ 49	150	134	171.5	410	150	206	180